



INTERNATIONAL INSTITUTE FOR THE UNIFICATION OF PRIVATE LAW
INSTITUT INTERNATIONAL POUR L'UNIFICATION DU DROIT PRIVE

DIPLOMATIC CONFERENCE TO ADOPT A
CONVENTION ON SUBSTANTIVE RULES REGARDING
INTERMEDIATED SECURITIES

**Committee on Emerging Markets Issues,
Follow-up and Implementation**

Fourth Meeting
Beijing, 29 – 30 March 2017

UNIDROIT 2017
S78B/CEM/4/Doc. 2
Original: English
January 2017

Revised Draft

27 January 2017

UNIDROIT Legislative Guide on Intermediated Securities

Implementing the Principles and Rules of the Geneva Securities Convention

PREFACE

[Placeholder]

CONTENTS

PREFACE	2
CONTENTS	3
LIST OF CONTRIBUTORS	6
LIST OF ABBREVIATIONS	7
GLOSSARY	8
GENERAL INTRODUCTION	13
I. OVERVIEW ON SECURITIES	14
A. Basics of securities and securities holding	14
B. Intermediated securities holding models	21
II. THE GENEVA SECURITIES CONVENTION	27
A. Purpose	27
B. Approach	28
C. Terminology	29
D. Scope	30
E. Law outside of the Convention	30
III. RIGHTS OF ACCOUNT HOLDERS AND DUTIES AND LIABILITIES OF INTERMEDIARIES ..	32
A. Rights of account holders	32
1. Core Convention principles and rules	32
2. Choices to be made by declaration	33
3. Matters to be addressed or clarified	33
B. Measures to enable the exercise of rights of account holders	36
1. Core Convention principles and rules	36
2. Choices to be made by declaration	37
3. Matters to be addressed or clarified	37
C. Liability of intermediaries	39
IV. TRANSFER OF INTERMEDIATED SECURITIES	40
A. Acquisition and disposition of intermediated securities	40
1. Transfer by debit and credit method	40
a. Core Convention principles and rules	40
b. Choices to be made by declaration	41
c. Matters to be addressed or clarified	41
2. Transfer by other methods	42
a. Core Convention principles and rules	42
b. Choices to be made by declaration	43
c. Matters to be addressed or clarified	44
B. Unauthorised dispositions and invalidity, reversal and conditions	45

1.	Core Convention principles and rules	45
2.	Choices to be made by declaration	46
3.	Matters to be addressed or clarified	46
C.	Protection of an innocent acquirer	47
1.	Core Convention principles and rules	47
2.	Choices to be made by declaration	49
3.	Matters to be addressed or clarified	49
D.	Priorities.....	49
1.	Core Convention principles and rules	49
2.	Choices to be made by declaration	50
3.	Matters to be addressed or clarified	50
V.	INTEGRITY OF THE INTERMEDIATED HOLDING SYSTEM	51
A.	Prohibition of upper-tier attachment	51
1.	Core Convention principles and rules	51
2.	Choices to be made by declaration	52
3.	Matters to be addressed or clarified	53
B.	Prevention of shortfalls and allocation of securities	53
1.	Core Convention principles and rules	53
2.	Choices to be made by declaration	55
3.	Matters to be addressed or clarified	55
C.	Securities clearing and settlement systems.....	56
1.	Core Convention principles and rules	56
2.	Choices to be made by declaration	57
3.	Matters to be addressed or clarified	57
D.	Issuers.....	58
1.	Core Convention principles and rules	58
2.	Choices to be made by declaration	60
3.	Matters to be addressed or clarified	60
VI.	INSOLVENCY PROTECTION	61
A.	Core Convention principles and rules.....	61
B.	Choices to be made by declaration.....	62
C.	Matters to be addressed or clarified	62
VII.	SPECIAL PROVISIONS IN RELATION TO COLLATERAL TRANSACTIONS	65
A.	Core Convention principles and rules.....	65
B.	Choices to be made by declaration.....	67
C.	Matters to be addressed or clarified	68
VIII.	CONFLICT OF LAWS ASPECTS	69

A.	The Convention’s sphere of application.....	69
B.	Traditional conflict of laws rules and their modernisation	70
C.	The Convention’s “tier-by-tier” approach and its interaction with conflict of laws rules.....	70
D.	Other conflict of laws rules.....	71
IX.	OTHER INSTRUMENTS AND REGULATIONS AND IMPLEMENTATION	72
A.	Links to other international instruments or regulations	72
B.	Overview of implementation in a domestic legal framework	73
	ANNEX 1: LIST OF LEGISLATIVE PRINCIPLES	75
	ANNEX 2: REFERENCES TO “NON-CONVENTION LAW”	77
	ANNEX 3: REFERENCES TO “APPLICABLE LAW”	82
	ANNEX 4: REFERENCES TO RULES RELATING TO INSOLVENCY	83
	ANNEX 5: REFERENCES TO UNIFORM RULES OF SCSs AND SSSs	85

LIST OF CONTRIBUTORS

HIDEKI KANDA, *Emeritus Professor, University of Tokyo and Professor of Law, Gakushuin University*

PHILIPPE DUPONT, *Partner, Arendt & Medernach*

DOROTHEE EINSELE, *Professor of Law, University of Kiel*

FRANCISCO J. GARCIMARTIN ALFEREZ, *Professor of Law, Universidad Autónoma of Madrid*

PHILIPPE GOUTAY, *Partner, Jones Day*

THOMAS KEIJSER, *Senior Researcher, Radboud University*

MARIA CHIARA MALAGUTI, *Professor of Law, Catholic University of the Sacred Heart*

CHARLES W. MOONEY, JR., *Professor of Law, University of Pennsylvania*

LUC THEVENOZ, *Professor of Law, University of Geneva*

WU JING, *Senior Manager, Legal Department, China Securities Depository and Clearing Corporation Ltd.*

LIST OF ABBREVIATIONS

BIS	-	Bank for International Settlements
CCP	-	Central counterparty
CPMI	-	Committee on Payments and Market Infrastructure, Bank for International Settlements
CSD	-	Central securities depository
ESMA	-	European Securities and Markets Authority
EU	-	European Union
FMI	-	Financial markets infrastructure
FSAP	-	Financial Sector Assessment Program
FSB	-	Financial Stability Board
IMF	-	International Monetary Fund
IOSCO	-	International Organization of Securities Commissions
PRIMA	-	Place of relevant intermediary approach
SCS	-	Securities clearing system
SSS	-	Securities settlement system
UNCITRAL	-	United Nations Commission on International Trade Law
UNIDROIT	-	International Institute for the Unification of Private Law

GLOSSARY

The Glossary contains brief definitions or descriptions for key terms in the Guide. It includes the definitions or descriptions provided by the Geneva Securities Convention and the OFFICIAL COMMENTARY and, for other terms, relies to the extent possible on the definitions provided by CPMI's glossary of terms used in payments and settlements systems.

Account agreement

The agreement between the account holder and the relevant intermediary governing the securities account. See paragraph 108.

Account holder

A person in whose name an intermediary maintains a securities account, whether that person is acting for its own account or for others (including in the capacity of intermediary). See paragraph 70.

Applicable law

The law that is applicable by virtue of the private international law rules of the forum. The applicable law may, or may not, be the law of a Contracting State to the Geneva Securities Convention (i.e. the non-Convention law). See paragraph 75.

Book entry

An electronic recording of securities or other financial assets. The transfer of book-entry securities and other financial assets does not involve the physical movement of paper documents or certificates. See paragraph 16.

Book-entry system

A mechanism that enables market participants to transfer assets (for example, securities) without the physical movement of paper documents or certificates. See paragraph 16.

Central counterparty (CCP)

An entity which operates as the buyer for every seller and as the seller for every buyer so that the parties only bear the credit risk of the CCP. See paragraph 20.

Central securities depository (CSD)

An entity that provides the initial recording of securities in a book-entry system or that provides and maintains the securities accounts at the top tier of the intermediated holding chain. The entity may provide additional services such as clearing, settlement and processing corporate actions. It plays an important role in helping to ensure the integrity of securities issues. See paragraph 16.

Claw back

A statutory provision entitling an insolvency administrator to recover benefits, funds or other assets which have been unduly transferred to third parties before filing for insolvency. Claw back can also refer to a contractual provision regarding the benefits, funds or other assets which have been given out but need to be returned due to certain special circumstances which were predefined in the contract. See paragraph 273.

Clearing

The process of transmitting, reconciling and, in some cases, confirming transactions prior to settlement, potentially including the netting of transactions and the establishment of final positions for settlement. Sometimes this term is also used (imprecisely) to cover settlement. See paragraph 21.

Close-out netting provision

A provision of a collateral agreement, or of a set of connected agreements of which a collateral agreement forms part, under which, on the occurrence of an enforcement event, either or both of the following shall occur, or may at the election of the collateral taker occur, whether through the operation of netting or set-off or otherwise: (a) the respective obligations of the parties are accelerated so as to be immediately due and expressed as an obligation to pay an amount representing their estimated current value or are terminated and replaced by an obligation to pay such an amount; (b) an account is taken of what is due from each party to the other in relation to such obligations, and a net sum equal to the balance of the account is payable by the party from whom the larger amount is due to the other party. See paragraphs 271 and 289.

Control agreement

An agreement in relation to intermediated securities between an account holder, the relevant intermediary and another person or, if so provided by the non-Convention law, between an account holder and the relevant intermediary or between an account holder and another person of which the relevant intermediary receives notice, which includes either or both of the following provisions: (a) that the relevant intermediary is not permitted to comply with any instructions given by the account holder in relation to the intermediated securities to which the agreement relates without the consent of that other person; or (b) that the relevant intermediary is obliged to comply with any instructions given by that other person in relation to the intermediated securities to which the agreement relates in such circumstances and as to such matters as may be provided by the agreement, without any further consent of the account holder. See paragraph 141.

Corporate actions

Events called or initiated by an issuer of securities concerning the securities and the holders of the securities. See rights attached to the securities and paragraph 110.

Corporate law

The area of law dealing with the formation and operation of an issuer, which generally includes the rights of the account holder against the issuer of the securities. See paragraph 72.

Dematerialisation

The issuance (or re-issuance) of securities which are not represented by a physical certificate. The issue is usually documented by a record maintained by the issuer or a CSD or some other intermediary. The securities issued are credited to securities accounts. See paragraph 17.

Designating entry

An entry in a securities account made in favour of a person (including the relevant intermediary) other than the account holder in relation to intermediated securities, which, under the account agreement, a control agreement, the uniform rules of a SSS or the non-Convention law, has either or both of the following effects: (a) that the relevant intermediary is not permitted to comply with any instructions given by the account holder in relation to the intermediated securities as to which the entry is made without the consent of that person; or (b) that the relevant intermediary is obliged to comply with any instructions given by that person in relation to the intermediated securities as to which the entry is made in such circumstances and as to such matters as may be provided by the account agreement, a control agreement or the uniform rules of a SSS, without any further consent of the account holder. See paragraph 141.

Functional approach

An approach using language that is as neutral as possible and which formulates rules by reference to their results. For example, because confusion can easily arise from the varying traditions and conceptual frameworks of different systems of law, under the functional approach adopted by the drafters of the Geneva Securities Convention, terms such as "property" and "proprietary interests" were avoided, and instead more generic language such as "effects against third parties" was used. See paragraph 67.

Global or jumbo certificate

In the context of the immobilisation of securities, a certificate held in a book-entry system that represents all or part of the securities of a particular issue. See paragraph 16.

Immobilisation

The act of durably concentrating the holding of securities certificates with a depository to allow the crediting of an equal amount of securities to securities accounts and the transferability of such securities by way of book entry. See paragraph 16.

Intermediary

A person (including a CSD) who in the course of a business or other regular activity maintains securities accounts for others or both for others and for its own account and is acting in that capacity. See paragraph 70.

Intermediated holding chain

A term used to describe the relationship and interaction among the (possibly many) tiers of participants in an intermediated securities holding system. See paragraph 15.

Intermediated securities

Securities credited to a securities account or rights or interests in securities resulting from the credit of securities to a securities account. See paragraph 15.

Investor

A person or entity, such as individuals, companies, pension funds and collective investment funds, who acquire securities to make a profit or gain an advantage. See paragraph 22.

Issuer

A government or entity such as a company which issues securities. See paragraph 22.

Law outside the Convention

Law which may include non-Convention law, applicable law, insolvency rules or uniform rules of the SCSs and SSSs. See paragraph 75 and Annexes 2-5.

Negative control

A type of control in which the relevant intermediary is not permitted to comply with any instructions given by the account holder in relation to intermediated securities for which a designating entry or control agreement has been made without the consent of the person in whose favour such entry or agreement was made. See paragraph 146.

Netting arrangements

An arrangement by which debits and credits in respect of securities of the same description may be effected on a net basis. See paragraph 136.

“No credit without debit” rule

A rule whereby any credit to a securities account must have a corresponding debit to another securities account. See paragraph 130 et seq.

Non-Convention law

The law in force in the Contracting State referred to in Article 2 of the Geneva Securities Convention other than the provisions of that Convention. See paragraph 75 and Annex 2.

Omnibus account

An account of a relevant intermediary with its own (next-tier) intermediary in which securities held for more than one customer of the relevant intermediary are commingled. See paragraphs 51 and 213. This term may also refer to such an account in which securities held for customers of the relevant intermediary are commingled with securities the relevant intermediary holds for its own account.

Positive control

A type of control in which the relevant intermediary is obliged to comply with any instructions given by the person in whose favour a designating entry or control agreement had been made in relation to intermediated securities in such circumstances and for such matters as may be provided by the account agreement, a control agreement or the uniform rules of a SSS, without any further consent of the account holder. See paragraph 146.

Priority

Ranking among competing interests with respect to the same intermediated securities. See paragraph 182.

Private law

The area of law which regulates the relationships between individuals and private entities (e.g. contract law, tort law, etc.). See paragraph 75.

Relevant intermediary

The intermediary that, in relation to a securities account, maintains that securities account for the account holder. See paragraph 43.

Rights attached to the securities

Rights which accrue to a holder of securities by virtue of holding the securities, such as dividends, other distributions, and voting rights, as well as the right to receive information necessary for account holders to exercise those other rights. See paragraph 24.

Securities account

An account maintained by an intermediary to which securities may be credited or debited. See paragraphs 15 and 70.

Securities clearing system (SCS)

A system that clears, but does not settle, securities transactions through a CCP or otherwise and is operated by a central bank or central banks or is subject to regulation, supervision or oversight by a governmental or public authority in relation to its rules. To qualify as a SCS under the Geneva Securities Convention, it must also be identified as such in a declaration made by the Contracting State the law of which governs the system on the ground of the reduction of risk to the stability of the financial system. See paragraph 70.

Securities settlement system (SSS)

A system that settles, or clears and settles, securities transactions and is operated by a central bank or central banks or is subject to regulation, supervision or oversight by a governmental or public authority in relation to its rules. To qualify as a SSS under the Geneva Securities Convention, it must also be identified as such in a declaration made by the Contracting State the law of which governs the system on the ground of the reduction of risk to the stability of the financial system. See paragraph 70.

Security interest

A security interest is a limited interest in assets (such as a lien, pledge, charge, or title transfer) which secures an obligation. See paragraph 19.

Segregated account

An account structure in which a specific intermediary holds the securities belonging to one or more account holders in an account with its own (relevant) intermediary that is distinct (segregated) from the securities it holds for itself or for other account holders. See paragraph 213.

Settlement

A process which discharges the obligations arising out of the agreement of the parties to transfer securities. Securities settlement may represent the conclusion and fulfilment of a stock exchange transaction between two or more parties (i.e. a trading object is exchanged for a cash counter value). Resulting obligations can be redeemed either in central bank or book money. Settlement is normally preceded by clearing. See paragraph 21.

Transfer

The acquisition and disposition of intermediated securities and any limited interests (e.g. security interests) therein. See paragraph 123 et seq.

Transparent systems

Systems in which an investor's particular holdings are identified by, or known to, the CSD primarily because the role of maintaining a securities account is shared between the CSD (which is the relevant intermediary for the purpose of the Convention and the Guide) and other persons often called account operators, such as investment firms, securities dealers, etc. See paragraph 51.

Upper-tier attachment

An attachment of intermediated securities at any level in the chain above its debtor's immediate intermediary, which is generally prohibited in the Geneva Securities Convention. See paragraph 199.

Usufruct

A limited and temporary proprietary interest in intermediated securities which the owner of those securities confers on a person and which entitles that person to derive income or benefit from that property. See paragraph 94.

GENERAL INTRODUCTION

1. The UNIDROIT Legislative Guide on Intermediated Securities (the Guide) addresses important matters to be considered in the creation of an intermediated securities holding system or the evaluation of an existing system. The Guide summarises the key principles and rules from the UNIDROIT Convention on Substantive Rules for Intermediated Securities (the Geneva Securities Convention or the Convention) and offers recommendations and guidance on those principles and rules as well as related matters not addressed in the Convention.
2. As the Convention’s drafters adopted a core and functional harmonisation approach, the Convention provides harmonised rules regarding certain intermediated securities issues, but also leaves various issues to be defined and determined by other rules of law in force in a Contracting State. The Guide complements the Convention by addressing these issues and, like the Convention, seeks to improve the legal framework for holding and transfer of intermediated securities, in order to enhance the internal soundness of domestic financial markets and their cross-border compatibility and, as such, to promote sustainable capital formation. In particular, the Guide explains what is and what is not covered by the Convention and provides guidance for States to consider in creating an intermediated securities holding system or evaluating an existing one. The Guide thus makes clear that the Convention is capable of accommodating different domestic holding systems and rendering their interactions significantly less risky and more predictable.
3. The Guide further seeks to promote the creation of comprehensive and coherent sets of legal rules for intermediated securities in two ways. First, in complementing the Convention, it is hoped that the Guide will promote its adoption and implementation. Second, in summarising the Convention’s key principles and rules, it is hoped that, even where the Convention is not adopted, such principles and rules could be chosen and implemented in those systems. Either way, the end result would be enhanced legal certainty and economic efficiency with respect to the holding and transfer of intermediated securities, in both domestic and cross-border situations.
4. The Guide is structured in nine Parts. Part I provides an overview on securities, describing their origins and development and identifying five general models of intermediated securities holding systems. Part II describes in brief the Geneva Securities Convention, including its purpose to reduce legal uncertainty and risk, its core and functional harmonisation approach, and the important role of law outside the Convention. Parts III-VII identify legislative principles, summarise key principles and rules regarding holding and transfer of intermediated securities, and explain their interaction with law outside the Convention. These Parts include coverage of the rights of account holders and the duties and liabilities of intermediaries (Part III), the transfer of intermediated securities (Part IV), the integrity of the intermediated holding system (Part V), insolvency protection (Part VI), and special provisions in relation to collateral transactions (Part VII). Lastly, Parts VIII-IX also identify legislative principles and provide overviews on conflict of laws aspects (Part VIII) and on other instruments and regulations and the implementation of the Convention or its principles and rules in a domestic legal framework (Part IX). In addition, model examples of legislative or regulatory texts or related descriptions, as well as bibliographic references, are included on UNIDROIT’s webpage for the Guide, which is available at: [\[HYPERLINK FOR FUTURE WEBPAGE TO BE INSERTED\]](#).
5. Lastly, it must be noted at the outset that the Guide is not intended to assist judges, arbitrators or practitioners in interpreting the Convention’s principles and rules or understanding its implications. The Official Commentary on the UNIDROIT Convention on Substantive Rules for Intermediated Securities (the “OFFICIAL COMMENTARY”) provides such comprehensive guidance and the Guide, accordingly, draws from it extensively.

I. OVERVIEW ON SECURITIES

6. This Part provides an overview on securities. First, Part I.A describes the basics of securities and securities holding. Second, Part I.B identifies and briefly discusses five general models of intermediated securities holding systems.

A. *Basics of securities and securities holding*

7. Governments and companies need money to finance their activities, and they often raise money from the public. For that purpose, they may issue bonds, which are bought and sold by investors in capital markets. The investors commit to lend money, known as the principal, to the issuers and, in exchange, the issuers commit to pay interest and repay the principal amount of the bond when it matures.

8. Companies, in addition, may issue shares, which are also bought and sold by investors in capital markets. Investors who purchase and hold shares commit to provide the money to the issuers and, in exchange, the issuers commit to pay the investors dividends (e.g. a portion of a company's profit) and to grant them particular participatory rights in the company, such as voting rights in shareholder meetings.

9. Bonds and shares, as well as other financial instruments or assets, are generally known as securities, although the definition varies from system to system. There are thus many different types of securities, including bonds and other debt instruments traded in the capital markets; shares and other equity instruments, whether or not they are traded on an exchange; and transferable units – other than shares – in collective investment schemes.

10. Securities holding, which may be non-intermediated or intermediated, is both a mainstay of the international financial system and a major component of the world's economy. For instance, BIS estimated in December 2016 that the total outstanding amount of global debt securities was \$102.3 trillion (USD), of which \$80.6 trillion was from domestic debt securities and \$21.7 trillion was from international debt securities. See BIS Quarterly Review (December 2016), Graph C.1 and related statistics.

1. Non-intermediated securities

11. Securities were traditionally issued in the form of physical certificates or by recordation in the issuer's register, or both. Non-intermediated securities generally can be unregistered or registered and be certificated or uncertificated.

12. Unregistered non-intermediated securities are those where the holder of the securities, usually referred to as the bearer, is not known to the issuer, but holds physical certificates. In this kind of holding, ownership of the securities generally vests in the holder, who may sell them by delivery of the physical certificates to a buyer in exchange for the payment of an agreed price and, where necessary, an agreement to transfer ownership to the buyer.

13. Registered non-intermediated securities are those where the holder of the securities is known to the issuer, which records ownership of the securities in the name of the holder in its register. The issuer's recordation of securities ownership enables it to send, for example, dividend payments or voting information directly to the holder of the securities.

14. Registered non-intermediated securities can be either certificated or uncertificated. If certificated, the issuer, in addition to recordation of the holder's ownership of the securities in its register, issues a securities certificate to evidence such ownership. Delivery of the securities certificate to a buyer with a contractual agreement to transfer generally transfers ownership to the buyer. Usually the securities would be endorsed to the buyer, with the issuer to record such transfer from the seller to the buyer in its register, or the securities may be endorsed in blank. If uncertificated, no securities certificates are issued and the holder of such securities can sell them by contractual agreement with a buyer, in which case the issuer would record that transfer from the seller to the buyer in its register.

2. Intermediated securities

15. Due to technological advances, it is no longer necessary to hold securities in physical paper form or to register ownership or transfers directly in an issuer's paper register. Holding and transfer of securities are now generally registered as electronic book-entries in securities accounts maintained by intermediaries, such as banks and other financial institutions, and they are referred to as intermediated securities. The intermediaries are an important link between the issuer and the investor in what are referred to as intermediated holding chains.

16. The emergence of the book-entry system is also connected with the immobilisation and dematerialisation of securities. Immobilisation involves durably concentrating the holding of securities in a central securities depository (CSD) – which is an intermediary that provides the initial recording of securities in a book-entry system or that provides and maintains the securities accounts at the top tier of the intermediated holding chain – to allow the crediting of an equal amount of securities to securities accounts and the transferability of such securities by way of book entry. The deposit of securities at the CSD may be done in the form of individual certificates, a combined certificate, known as a global or jumbo certificate which represents all or part of the securities of a particular issue, or a letter by the issuer evidencing entrustment with the CSD of a certain quantity of securities of a specific type. Transfers of immobilised securities thus can take place by electronic book-entries by intermediaries and do not require actual movement of certificates.

17. Dematerialisation goes further than immobilisation and eliminates certificates altogether. The securities are represented by book-entries alone throughout the intermediated holding chain.

18. Intermediation, immobilisation and dematerialisation have reduced significantly and, in some systems, even eliminated the paperwork traditionally necessary for securities transfers. These developments have accordingly allowed for greater numbers of holdings and transfers and increased the size of capital markets.

3. Common securities transactions

19. Securities are bought and sold on capital markets, and there are many types of securities transactions. Some common transactions are so-called "plain" sales of securities, creation of a security interest, repurchase transactions, and securities lending transactions:

(a) A "plain" sale of securities against payment.

(b) A transaction that involves a security interest in securities. For example, if Company A loans cash to Company B for the purchase of securities, a security interest may be created in those securities in favour of Company A, in order to ensure that A can recover the value of the loan. In the event that Company B defaults in repaying the loan, Company A could obtain the securities and sell them to recover what Company B owes.

(c) In a repurchase (or "repo") transaction, a seller seeking cash transfers securities to a buyer outright in exchange for cash at the purchase date, while the seller returns the cash together with an interest component at the repurchase date in exchange for equivalent securities. See, e.g., diagram 278-1 below.

(d) A securities lending transaction is similar to a repo, except that the borrower seeks transfer of ownership of specific securities with a promise to return equivalent securities, which may be collateralised with cash or securities. For example, a lender transfers securities (e.g. 100 shares of Company A) to a borrower who transfers securities (e.g. 100 shares of Company B) to the lender and, at a later date, both parties transfer equivalent securities and the borrower pays a fee.

20. Market participants may enter into multiple transactions every day. Such transactions occur on various exchanges or trading platforms, or on the so-called “over-the-counter” market. Many transactions are cleared and settled through a central counterparty (CCP), an entity which operates as the buyer for every seller and as the seller for every buyer so that the parties only bear the credit risk of the CCP. Where multiple transactions are made each day, it makes sense not to transfer gross quantities per transaction but, where possible, to net transfer obligations at predetermined times and to transfer only the resulting net amount.

21. The transaction process involves what is known as clearing and settlement. First, clearing refers to the process of transmitting, reconciling and, in some cases, confirming transactions prior to settlement, potentially including the netting of transactions and the establishment of final positions. Sometimes this term is also used imprecisely to cover settlement. Second, settlement implies the process which discharges the obligations arising out of the agreement of the parties to transfer securities (e.g. the exchange of cash counter value for the traded securities and the credit of securities to the account of the buyer).

4. Securities holding chains

22. In the context of securities holding, as mentioned above, there are various key participants, which occupy different places in securities holding chains. These participants include:

(a) Issuers – at the origin of the chain – such as a government issuing bonds or a company issuing bonds or shares;

(b) Intermediaries – in the middle of the chain – such as a CSD, which is responsible for keeping paper securities, if any, maintaining electronic records, and administering them, and banks or other financial institutions which maintain accounts on behalf of investors or on their own behalf; and

(c) Investors – at the end of the chain – such as individuals, companies, pension funds and collective investment funds who acquire securities.

23. The following is an overview, together with basic securities holding diagrams, of (a) non-intermediated holding and (b) intermediated holding.

a. Non-intermediated holding

24. In traditional non-intermediated securities holding, there are no intermediaries between the issuer and the investor. Such holding may encompass, for example, certificated securities held physically by the investor (diagram 24-1), securities directly registered in the issuer’s register in the investor’s name (diagram 24-2) or both (diagram 24-3). The advantage of such a direct connection between the issuer and the investor is that the issuer is able to identify the investor (except for unregistered (bearer) securities) and the investor is able to exercise the rights attached to the securities (e.g. rights which accrue to a holder of securities by virtue of holding the securities, such as dividends, other distributions, and voting rights, as well as the right to receive information necessary for account holders to exercise those other rights) directly with the issuer. The investor also does not bear the risks attendant to the insolvency of an intermediary as there is no intermediary.

Diagram 24-1: Non-intermediated securities holding – physical certificates

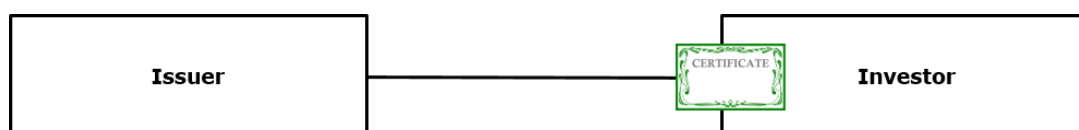

Diagram 24-2: Non-intermediated securities holding – entries in the issuer’s register

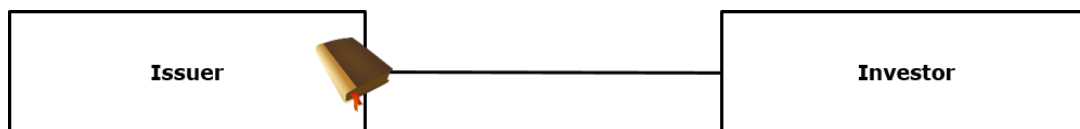
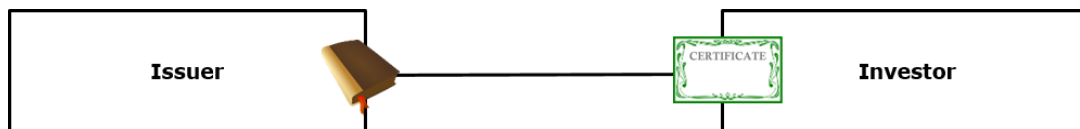

Diagram 24-3: Non-intermediated securities holding – physical certificates and entries in the issuer’s register



b. Intermediated holding

25. In an intermediated holding chain, there is at least one intermediary – and possibly more – between the issuer and the investor. Such chains may involve, for example, immobilised securities certificates held by the CSD (diagram 25-1) or dematerialised securities represented solely by electronic book-entries recorded by the CSD (diagram 25-2). In addition, an issuer’s register may be run by a CSD or an agent, whether the chain involves immobilised securities certificates or dematerialised securities.

Diagram 25-1: Intermediated securities holding chain – immobilised securities certificates

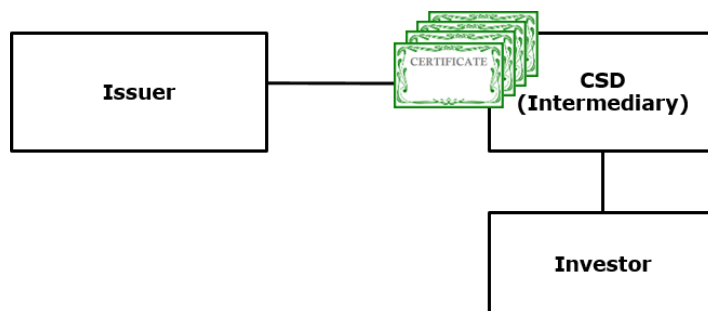
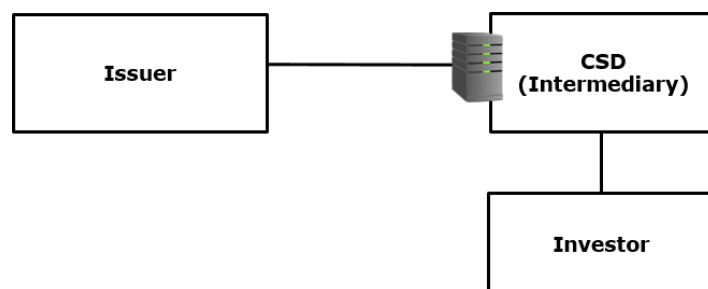

Diagram 25-2: Intermediated securities holding chain – dematerialised securities



26. The following provides examples of domestic and international intermediated holding chains. Because of the possible variations, the diagrams are simplified to show basic, static links in holding chains between issuers, intermediaries, and investors.

(i) Domestic examples

27. Domestic intermediated holding chains can be simple. As shown in diagram 25-1 and 25-2 above, the CSD, for example, may be the only intermediary between the issuer and the investor. In some systems, there are no intermediaries involved other than the CSD, and the investors hold their securities directly with the CSD. Apart from safekeeping of securities, the CSD may act merely as a conduit for communications between the issuer and the investor. In others, the CSD may have more responsibilities

and play a greater role in a particular securities clearing or settlement system for the efficient transfer of securities, depending on how such responsibilities are divided among CSDs, stock exchanges, central banks, and other market participants.

28. Domestic intermediated holding chains, however, can also be rather long, with several links of intermediaries between the issuer and the investor. In such chains, investors are at the end of the chains, with their securities accounts maintained by intermediaries. For instance, an investor may enter into an agreement with an intermediary to manage the relationship with the CSD (e.g. serve as the technical interface between the investor and the CSD). Diagram 28-1 shows an example where a top-tier intermediary (CSD) holds the securities in an account on behalf of another intermediary (#2), and the latter holds them on behalf of the investor.

Diagram 28-1: Domestic intermediated securities holding chain with two intermediaries

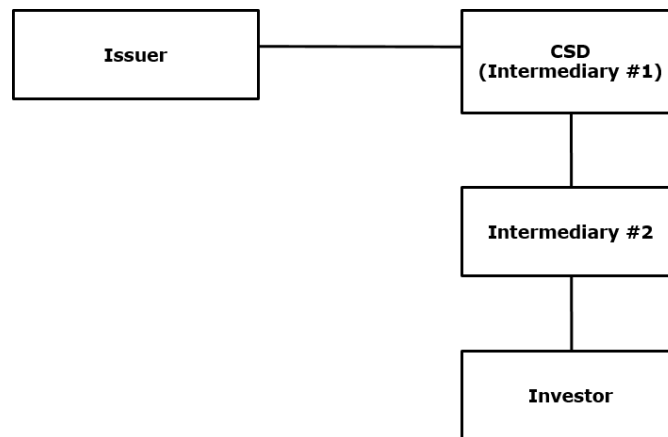

29. Naturally, holding chains may become even more complex as the number of intermediaries increases, as diagram 29-1 shows. The CSD keeps the securities and maintains an account for intermediary #2, which in turn maintains an account for intermediary #3, which in turn maintains an account for the investor. Such chains are actually quite common in the book-entry system. Regulation of intermediaries, as a result, becomes very important and, in some systems, intermediaries are extensively regulated. In markets, intermediaries can be broker-dealers, banks or investment entities and can also be referred to as "custodians," "sub-custodians," or by other terms. The Guide, however, generally refers to them as intermediaries. See paragraph 70.

Diagram 29-1: Domestic intermediated securities holding chain with three intermediaries

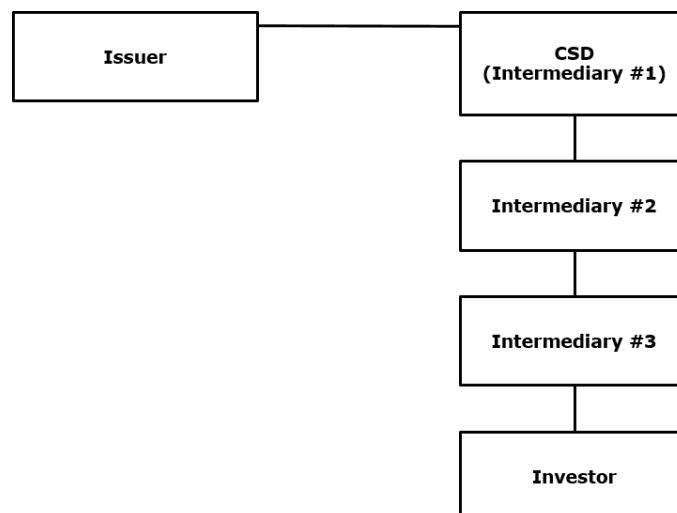

30. Even in these domestic examples, the presence of intermediaries between the issuers and investors means that the issuers and investors may not have a direct relationship. Absent proper laws and regulations within a domestic system, it may be difficult to determine who is entitled to exercise the rights attached to the securities. It depends, for example, on whether that system enables an investor at one end of the chain to exercise its rights directly with the issuer, or whether those rights are passed along and exercised via the chain of intermediaries.

(ii) *International examples*

31. In today's capital markets, investors in securities are no longer confined within domestic boundaries. On the contrary, investors often buy securities from issuers based in other jurisdictions. Cross-border holding chains often involve several intermediaries, and the following examples are included in this regard.

32. In some international holding chains, the CSD is located in a different State than the issuer. For example, as shown in diagram 32-1 below, a company in State A opts to register its securities with a CSD in State B for various reasons. In such a case, that company registers and deposits the securities with State B's CSD, which is the first intermediary in the holding chain. Intermediary #2 has an account with the CSD, to which the securities are credited. Intermediary #2 credits those securities to the account that it maintains on behalf of intermediary #3, and intermediary #3 credits those securities to the account it maintains on behalf of the investor.

Diagram 32-1: Cross-border intermediated securities holding chain spanning two States in which the issuer opted to use a foreign CSD

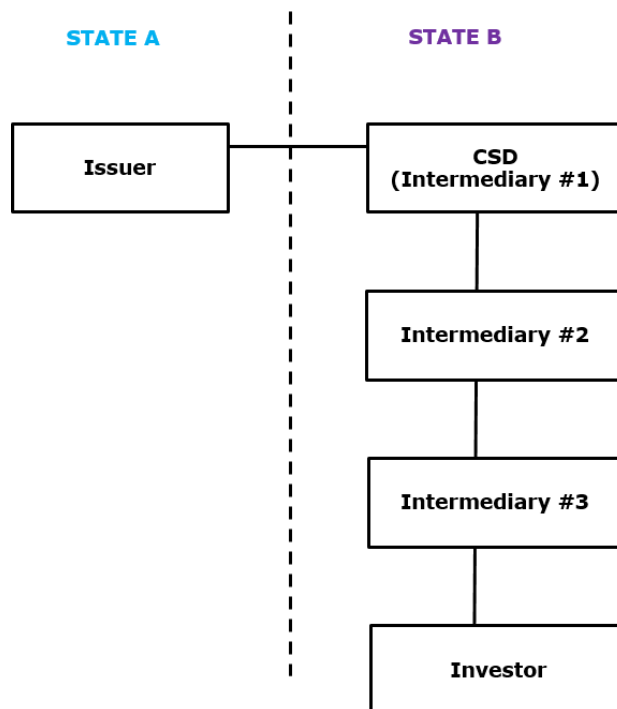

33. In most international holding chains, however, the CSD is located in the same State as the issuer. As shown in diagram 33-1 below, the securities are issued by a company in State A and deposited with the CSD (intermediary #1). There is another intermediary in State A, a local investment firm (intermediary #2), which has an account with the CSD, to which the securities are credited. The investment firm allocates those securities overseas to an international bank based in State B (intermediary #3), which credits them to the securities account of an investor in that State.

Diagram 33-1: Cross-border intermediated securities holding chain spanning two States

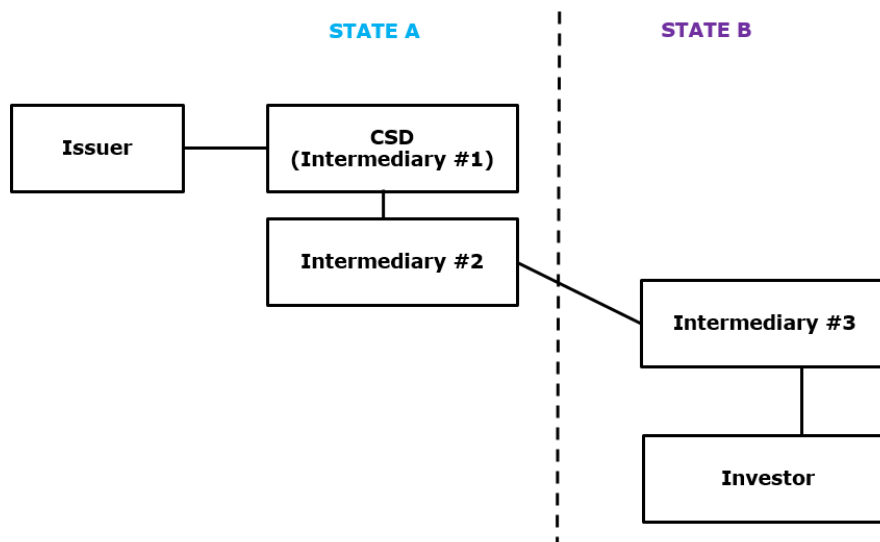

34. International holding chains, as shown in diagram 34-1 below, can reach across more than one border. In this example, the securities are issued by a company in State A. Under State A's law, all securities issued by companies in that State must be kept and registered at State A's CSD. This CSD is the first intermediary and monopolises the market for registering securities in State A. There is another intermediary in State A, a local investment firm (intermediary #2), which has an account with the CSD, to which the securities are credited. The investment firm allocates those securities overseas, to an international bank based in State B (intermediary #3). A local bank in State C (intermediary #4) acquires those securities on behalf of an investor from State C. As soon as the intermediary in State B allocates those securities to the local bank's securities account, the local bank in turn credits them to the investor's securities account.

Diagram 34-1: Cross-border intermediated securities holding chain spanning three States

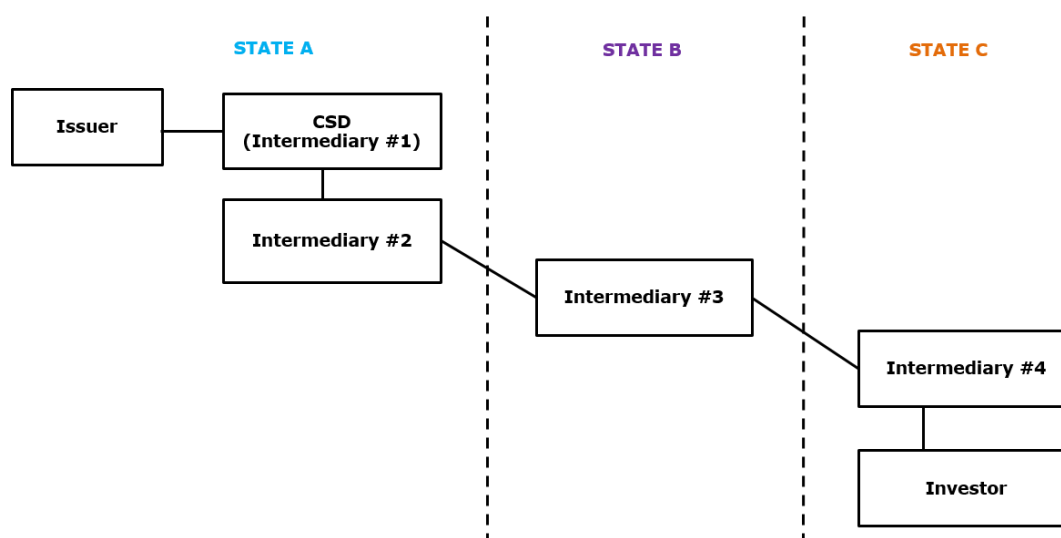

35. In these international examples, the investor's exercise of the rights attached to the securities may prove to be difficult. A particular domestic law, for example, may not recognise the rights or interests of investors located in another jurisdiction, may prevent intermediaries from acting on behalf of those investors, or may not facilitate sufficiently the exercise of the investors' rights via the holding chain. In addition, the relationship between intermediaries across borders is governed by contractual arrangements. Subject to laws and regulations in a particular system, it is the contract itself which defines the rights and obligations between the intermediaries involved. If the contract does not contemplate the obligation to pass the rights attached to the securities via those intermediaries, the exercise of such rights by the investor at the end of the chain may be disrupted. These examples, moreover, generally involve simplified, static

holdings and not transfers. In reality, securities holding chains can fluctuate on a daily basis and involve many intermediaries and account holders, and different laws may be applicable to particular links in the chain. See generally Part VIII below.

5. Risks associated with intermediated securities

36. There are risks associated with the holding and transfer of intermediated securities, ranging from unauthorised disposition to the insolvency of intermediaries. Especially in the cross-border context, the most central risk to the holding of intermediated securities arises from legal uncertainty surrounding how different jurisdictions treat the rights of account holders in relation to their intermediated securities.

37. Investors want to be certain about the legal regime which will determine their rights in intermediated securities, for example, in the event of disputes or the insolvency of an intermediary. If an intermediary is financially distressed and becomes insolvent, there may be a shortfall in securities, whereby the intermediary does not have enough securities on hand to satisfy those credited to its account holders' securities accounts. In this way, an intermediary's insolvency can both put the holdings of investors at the end of the chain at risk and pull other intermediaries into insolvency as well, thereby threatening systemic effects. Such effects may be compounded where there are multiple intermediaries located in different jurisdictions with different applicable insolvency laws.

38. Harmonisation efforts like the Geneva Securities Convention and the Guide aim to reduce legal uncertainty and thus the risks associated with intermediated securities. It must be noted, however, that such efforts are not a panacea for all risks associated with intermediated securities.

B. Intermediated securities holding models

39. At present, there is no international uniform legal approach for intermediated securities holding systems. It is possible, however, to identify five general models of holding systems (i.e. individual ownership, co-ownership, trust, security entitlement, and contractual), which are referred to throughout the Guide and are discussed briefly below. Diagrams are provided for each of them, though they are not necessarily representative of every system under a particular model and show only the static holding of intermediated securities and not the flow of rights, such as voting rights and distributions, via the holding chain. The models, moreover, are neither exhaustive nor mutually exclusive, as some systems might be mixed systems because, for instance, different models may be used for particular types of securities. Indeed, systems evolve over time, and there is accordingly a need for flexibility in the legal approaches governing them. Following discussion of the five general models, an important distinction regarding identification of the investor in the holding chain is discussed in greater detail and a more complicated cross-border example is provided.

1. Individual ownership model

40. Under the individual ownership model, neither the CSD nor any of the other intermediaries have any interest in the securities as the investor has full, individual ownership over the securities, which are deemed to be located directly in the investor's securities account. In the French system, for example, in which all securities issued are dematerialised, or for foreign securities immobilised, securities are recorded by way of book-entries at the CSD, which acts simply as a register for the issuer and other participants acting on behalf of the issuer. Neither the CSD nor any of the other intermediaries have any interest in the securities as the investor has full, individual ownership over the securities, which are deemed to be located directly in the investor's securities account. The investor accesses its securities through its own account with its intermediary and not through any other intermediary.

41. In the event the CSD or any other intermediary becomes insolvent, the investor, as the owner of the securities, has the right to require a new recording of those securities in the investor's name. Intermediaries, including the CSD, do not have any right over such an investor's securities, except in specific situations where a security interest is provided to an intermediary.

Diagram 41-1: Individual ownership model

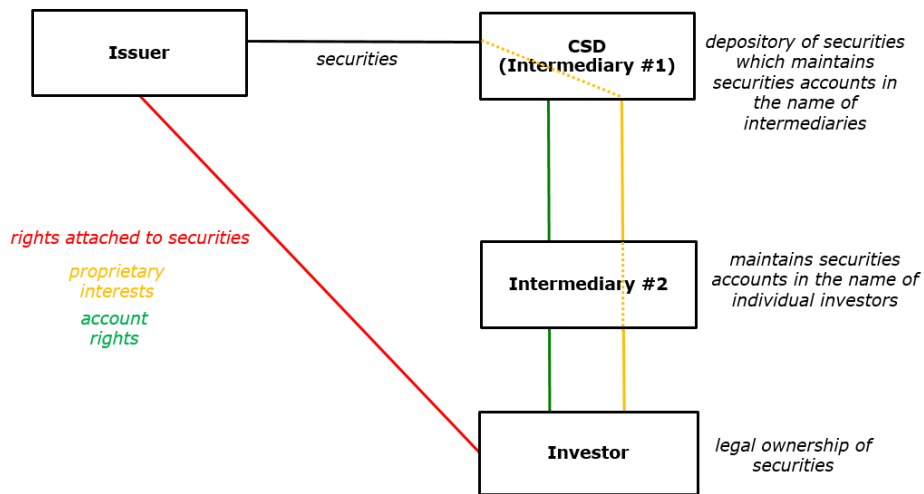

42. Some systems following this model are so-called transparent systems, which are described in paragraph 51 below.

2. Co-ownership model

43. Under the co-ownership model (e.g. Austria, Germany and several other civil law jurisdictions), securities are typically deposited by the issuer with the CSD in the form of a global certificate. The CSD, in turn, credits the securities accounts of its participants, typically banks acting as intermediaries for other intermediaries and investors. In this model, an investor has a shared interest. The investor has fractional ownership or, in other words co-ownership, corresponding to its holdings of a pool of securities held by the CSD. The investor accesses its securities through its intermediary and, as a result of the pooling of securities, the CSD and any other intermediaries above the investor’s intermediary (i.e. relevant intermediary) would be unable to identify a particular investor’s specific holdings.

44. In the event the CSD or another intermediary becomes insolvent, an investor’s securities do not become part of the insolvency estate, as neither the CSD nor the other intermediaries own the securities. The investor is entitled to exercise and, if necessary, enforce the rights attached to the securities.

Diagram 44-1: Co-ownership model

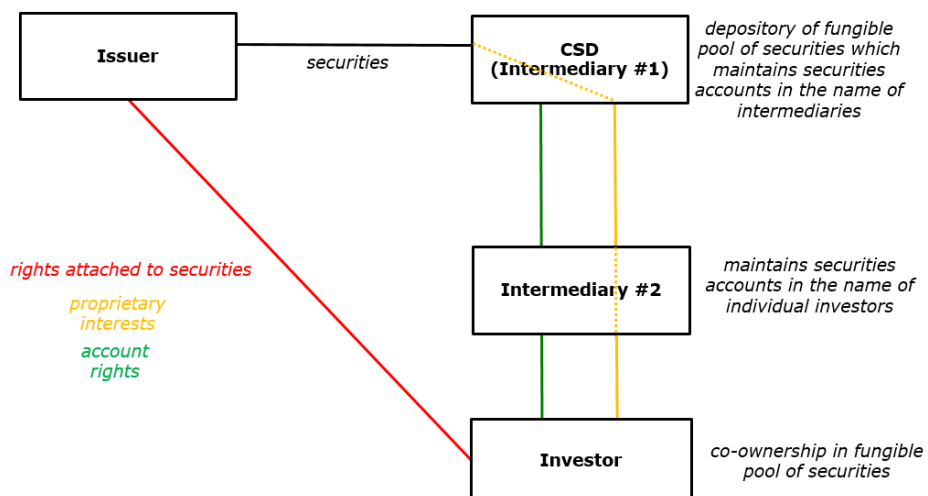

3. Trust model

45. In the trust model (e.g. Australia, England and Wales, and Ireland), issuers' securities are provided to the CSD for safekeeping, and the CSD acts as the issuers' register and has no legal interest in the securities. The CSD's participants, typically intermediaries such as banks and other financial institutions, are considered to be the legal owners of the securities, whether for themselves or on behalf of their clients. Once those intermediaries credit those securities to their account holders' securities accounts, they act as trustees for the account holders, who become beneficiaries and receive an equitable interest in the securities. Investors access their securities through their relevant intermediaries and not through those further up the holding chains.

46. In the event an intermediary becomes insolvent, the investor as a beneficiary has a proprietary interest over the securities, which cannot be claimed by the creditors of the intermediary.

Diagram 46-1: Trust model

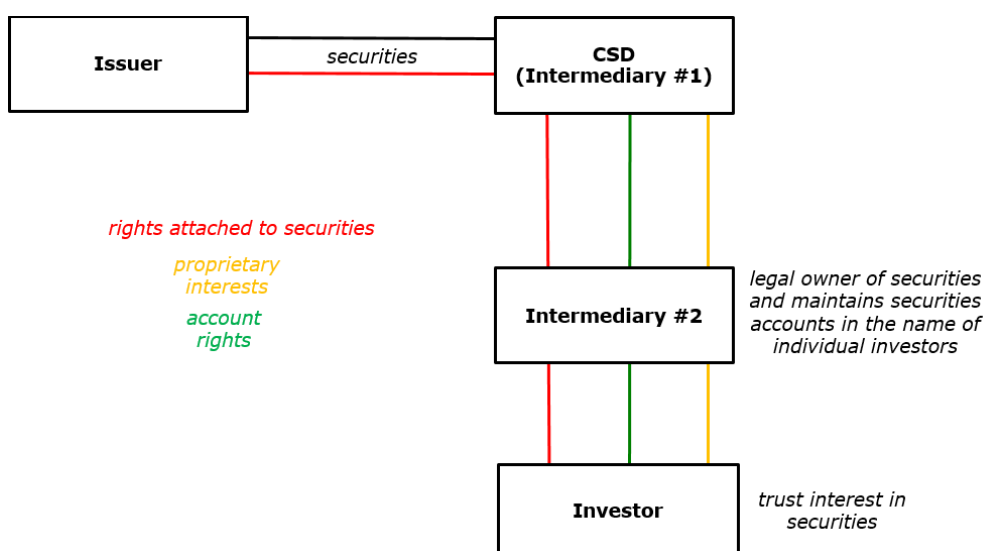

4. Security entitlement model

47. Under this model (e.g. Canada and the United States of America), every securities account holder receives a security entitlement (i.e. a *sui generis* bundle of rights against the intermediary and over the assets held by the intermediary) against its relevant intermediary. In other words, there are security entitlement holders at each level of the holding chain below the CSD. The entitlement holder has no ability to exercise economic or other rights to the financial asset directly against the issuer. The intermediary, however, has an obligation to obtain and pass on the rights attached to the securities to the entitlement holder and to exercise such rights on the entitlement holder's behalf. Investors at the end of the holding chain, which hold a security entitlement against their relevant intermediary, access the securities through that intermediary and not through other intermediaries in the chain.

48. In the event an intermediary becomes insolvent, the account holder is protected as security entitlements are separated from the intermediary's estate.

Diagram 48-1: Security entitlement model

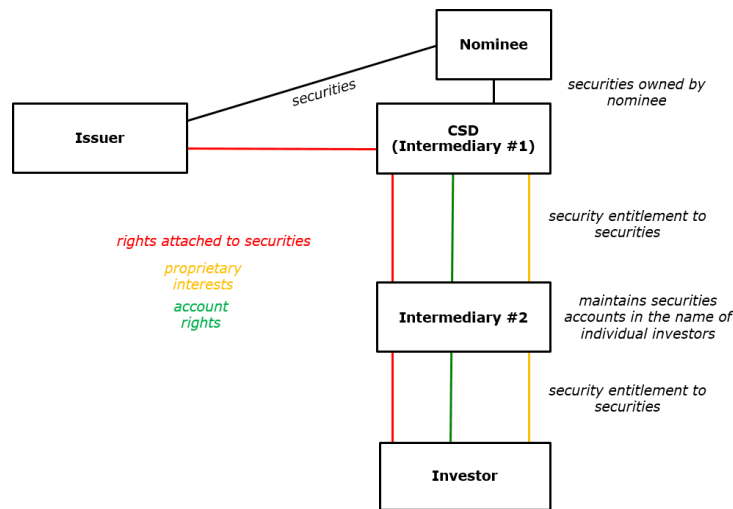

5. Contractual model

49. Under the contractual model, investors do not acquire a bundle of proprietary interests to the securities, but instead acquire contractual rights vis-à-vis the relevant intermediary. The entire holding system consists of a network of bilateral contracts among different market participants, from the CSD to the investor. The CSD or other intermediaries appear in the issuer’s book as the registered holders and, thereafter, the rights and benefits are to flow through the holding chain from one intermediary to another, eventually being available to the investors.

50. The terms and conditions of the relevant contracts between participants generally set out the legal framework on various issues, including the exercise of the investor’s rights or the consequences arising out of the insolvency of an intermediary. Domestic insolvency laws, however, usually determine the investor’s rights and claims against the intermediary’s estates with respect to securities to a considerable extent. In some systems, moreover, intermediaries may be structured so as to be insolvency-remote (i.e. by engaging only in custody and not in any other activity). For systems following this model, insolvency laws protecting investors or insolvent-remote intermediaries are essential because an investor’s contractual rights alone may not offer sufficient protection, for example, in the event of an intermediary’s insolvency.

Diagram 50-1: Contractual model

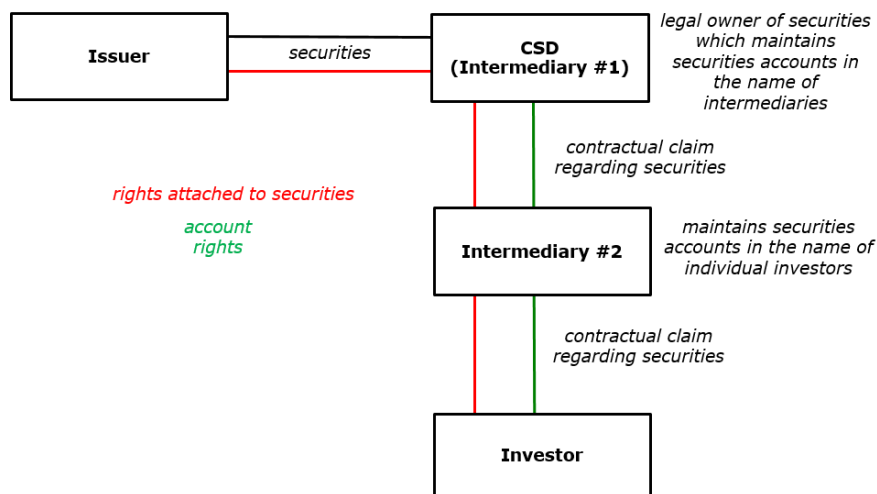

6. Identification of the investor: transparent and non-transparent systems

51. As noted above with respect to the individual ownership model, some systems are known as transparent systems. In such systems, an investor’s particular holdings are identified by, or known to, the CSD primarily because the role of maintaining a securities account is shared between the CSD (which is the relevant intermediary for the purpose of the Convention and the Guide) and other persons often called account operators, who are securities firms maintaining commercial relationships with investors. There are three general categories of transparent systems, and diagrams are provided for each:

(a) *When the investor’s holdings are held in an account with the CSD:* In such a system, there are separate accounts maintained at the CSD for each investor and the intermediaries merely operate these accounts. Any intermediaries thus serve the role of technical interface between the investor and the CSD.

Diagram 51-1: Transparent system in which the investor’s holdings are held in an account with the CSD

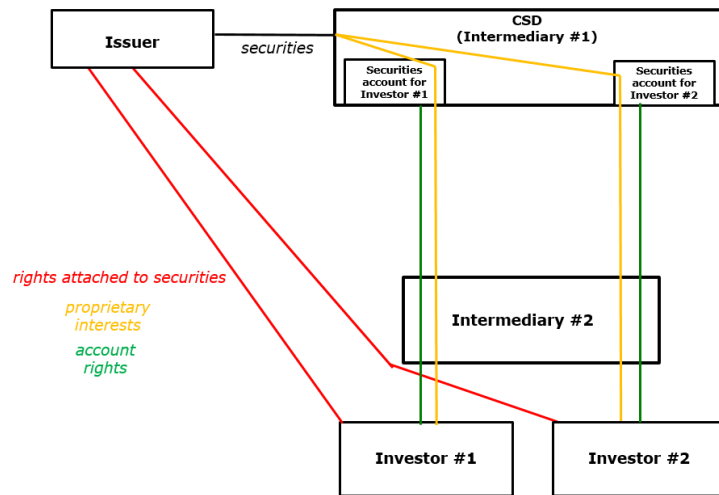

(b) *When the investor’s holdings are identified in an intermediary’s account with the CSD:* In such a system, the CSD maintains accounts in the name of intermediaries, and these accounts are divided into sub-accounts for each client of the intermediary and reflect each client’s holdings.

Diagram 51-2: Transparent system in which the investor’s holdings are identified in an intermediary’s account with the CSD

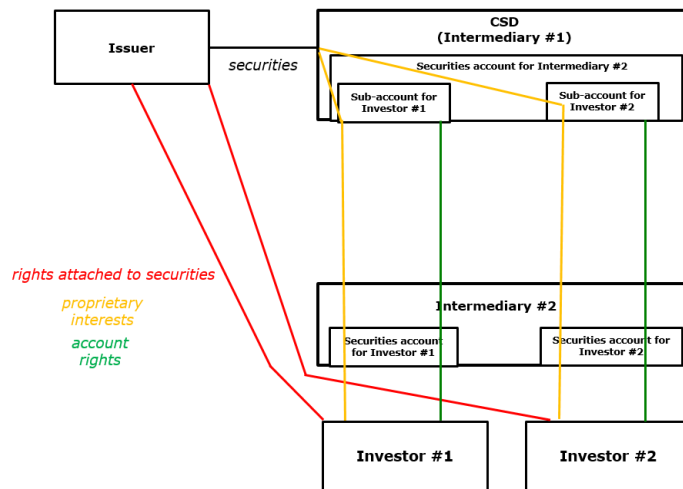

(c) *When the investor's holdings are held by an intermediary in an omnibus account at the CSD and account information is registered on a regular basis:* In such a system, there is an omnibus account at the CSD in the name of intermediaries, which maintain separate accounts in their register for their clients. Information regarding those separate accounts is permanently or regularly consolidated between the intermediaries and the CSD, thereby enabling the CSD to determine what exactly the clients hold.

Diagram 51-3: Transparent system in which the investor's holdings are held by an intermediary in an omnibus account at the CSD and account information is registered on a regular basis

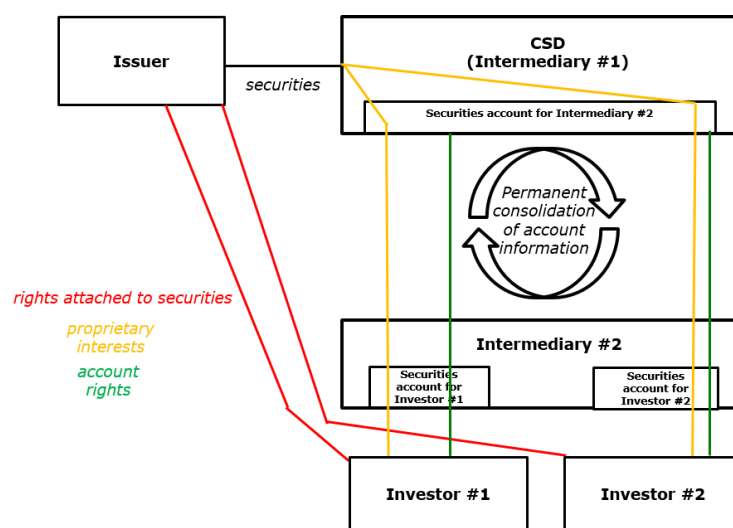

The common feature of these three categories is that investors and their individual holdings are identified at the CSD level.

52. Non-transparent holding systems, on the other hand, refer to those in which the investor's interest in securities is not identified at the level of the CSD, but only at the level of the relevant intermediary.

53. In some cases, as mentioned above, systems may be considered as "mixed" because one part of a holding chain in that system is transparent while the other part is non-transparent. In addition, most cross-border holding chains originating in a transparent system are mixed, in that a chain generally ceases to be transparent once it reaches across a border and becomes an international one.

7. Cross-border holdings involving multiple systems

54. Even between two internally sound and reliable domestic systems, holding securities through a chain of intermediaries across borders may give rise to various problems. First, the legal frameworks in which each market participant (issuers, intermediaries or investors) operates are different and they may not be calibrated to work together, thereby jeopardising the exercise of investors' rights. Second, some jurisdictions have in place legal frameworks based on traditional models of capital markets and concepts of property law. Traditional models, even if perfectly developed from a legal point of view, may not match the standards required by increasingly modern, interconnected, and even paperless capital markets. Third, in most cases, a conflict of laws issue may arise when trying to determine the applicable law with respect to particular participants and aspects of the holding chain.

55. For example, as shown in diagram 55-1 below, intermediary #2 holds securities in State A, which has a transparent individual ownership system. Such securities holding functions well under the domestic legal framework because that system is internally sound. Once some of those securities are transferred and held via intermediaries #3 (in State B, which follows the trust model) and #4 (in State C, which follows

the co-ownership model), however, the exercise of certain rights attached to the securities may become difficult.

Diagram 55-1: Varying ownership rights and interests in a cross-border intermediated securities holding chain spanning three States

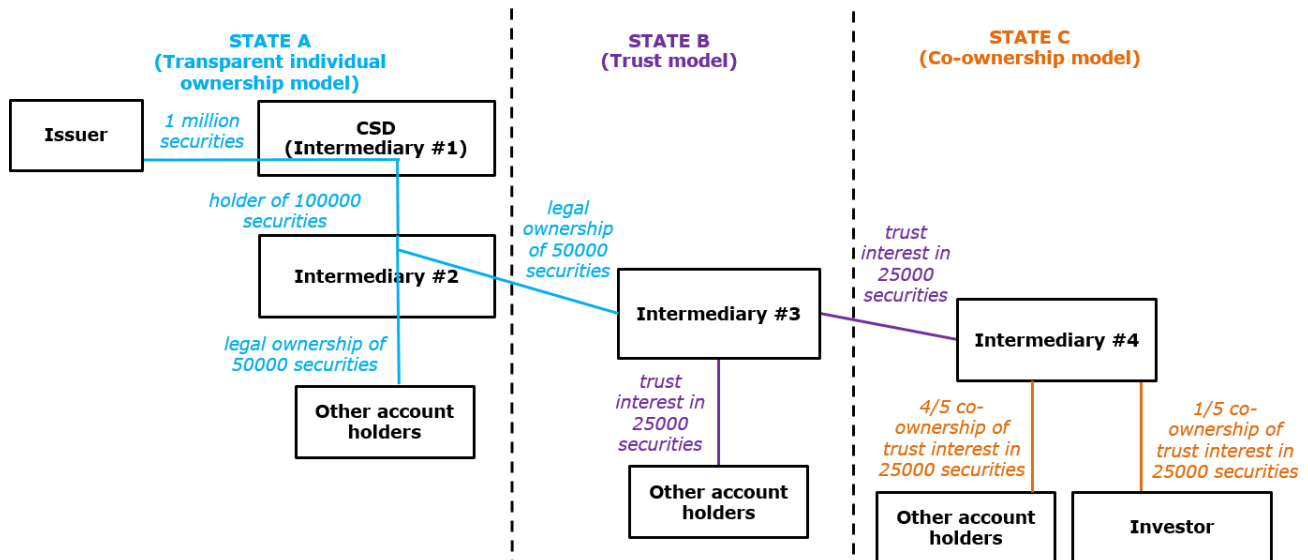

56. In particular, each of the account holders in diagram 55-1 – which includes intermediaries #2, #3, and #4 and the investor as they each have accounts with the respective intermediary above them in the holding chain – receives the legal position attributed to it under the relevant domestic legal analysis. Accordingly, various laws (e.g. property, commercial, insolvency) of different jurisdictions might apply to various parts of the same holding chain, creating uncertainty and possible incompatibilities.

II. THE GENEVA SECURITIES CONVENTION

57. This Part describes in brief the Geneva Securities Convention, including its (a) purpose; (b) approach; (c) terminology; (d) scope; and (e) references to law outside of the Convention.

A. Purpose

58. Intermediation in securities holding and the simultaneous developments of immobilisation and dematerialisation have enabled the rapid expansion of capital markets by reducing paperwork, allowing for an enormous volume of transactions every day, and promoting economic growth. Specific risks related to the physical existence of certificated securities have been largely eliminated with the introduction of book-entry systems, as such securities are no longer physically moved. Intermediated securities holding and transfer, however, are not without risks, as there may be significant legal uncertainty and even systemic risk, especially when such holding and transfer occurs cross-border. This section first describes these risks and then how the Geneva Securities Convention addresses them.

1. Legal and systemic risk

59. Intermediated securities holding and transfer are not free from risk. There may be legal risk in the application of existing law, especially when that law is based on traditional legal concepts not tailored to modern securities holding and transfer. This risk may be compounded when securities are held and transferred across borders because the various domestic systems may not necessarily be compatible with one another, and different substantive rules may apply to the various participants in a holding chain. Upon the insolvency of an intermediary, moreover, there could be significant risk regarding a potential shortfall in securities and whether the investor's interests in those securities are protected from the claims of the intermediary's general creditors as these issues may be handled differently in various systems. Such risk,

in some situations, may dissuade investors from acquiring particular securities. In many situations, such risk increases transaction costs and hampers economic growth.

60. These risks may even become systemic. In times of financial stress, the insolvency of one intermediary could lead to the insolvency of other intermediaries, thereby triggering systemic effects.

2. Harmonisation to reduce risk and promote sustainable economic growth

61. The Geneva Securities Convention, adopted in October 2009 and tailored to the modern book-entry system, was carefully developed to address and minimise these risks. The Convention provides the core legal framework for a modern intermediated securities holding system, which is both internally sound and compatible with other systems.

62. Regarding internal soundness, the Convention's drafters identified key features of intermediated holding systems which must be present in order for a particular system to be considered as sound, taking into account the objectives of investor protection and efficiency. Holders of intermediated securities should, for example, be confident that their interests are protected and subject to simple and clear rules and procedures regarding holding, transfer, and realisation. It was deemed essential, moreover, that the investor's interest not be exposed to risks such as the insolvency of any intermediary in the holding chain or interference by unrelated third parties.

63. Regarding compatibility, the drafters recognised that different legal systems should be able to interconnect successfully where intermediated securities are held and transferred across borders. In a cross-border context, as differing rules and approaches may apply in respect of property law issues, supervision, corporate law, etc., it was recognised that harmonisation of core issues was of the utmost importance.

64. A sound and compatible legal framework governing intermediated securities is essential for market stability and investor protection. It is all the more important in light of the extremely high value of securities held in intermediated systems and the enormous volume of intermediated securities transactions carried out on a daily basis. As that value and volume continues to increase, a proper legal framework could enhance the flow of capital and access to capital markets, thereby promoting sustainable economic development.

B. Approach

65. In recognising the diversity of legal concepts underlying securities holding around the world, the Convention embraces a core and functional harmonisation approach in order to accommodate different legal systems and traditions within a unitary framework. Only elements essential to the establishment of internal soundness and cross-border compatibility are addressed.

66. The Convention's approach is a core one in that it harmonises certain key matters related, for example, to the rights of account holders, securities transfers, and aspects of the integrity of the intermediated holding system. Other law is thus relied upon to cover matters not harmonised by the Convention.

67. The Convention's approach is functional in that it uses language that is as neutral as possible to formulate rules by reference to their results. Under a functional approach, harmonising rules are formulated by reference to facts rather than particular legal terms or principles to allow operative results to be reached without overriding the underlying domestic legal traditions and doctrine. With the functional approach, for example, the Convention is compatible with various characterisations of securities rights and interests and possesses the necessary flexibility to accommodate new technological advances and evolutions in intermediated securities holding systems. See paragraph 76 below.

68. The Convention's drafters also worked to ensure compatibility with other relevant instruments, including recent domestic reform legislation, EU directives, and international instruments, in particular the Hague Securities Convention and the UNCITRAL Legislative Guide on Secured Transactions. Whereas the Hague Securities Convention provides conflict of laws rules for intermediated securities as addressed in paragraphs 303 and 308 et seq. below, the Geneva Securities Convention provides substantive rules for such securities, and the two Conventions complement one another. The Geneva Securities Convention also complements the UNCITRAL Legislative Guide on Secured Transactions and the UNCITRAL Model Law on Secured Transactions, which are to assist States in developing modern secured transactions laws and are addressed in paragraph 290 below, because the UNCITRAL Legislative Guide does not cover securities at all and the UNCITRAL Model Law contains rules for non-intermediated securities only.

69. In addition, new technologies have been developed that may be applied to securities holding. In particular, the so-called distributed ledger technology is seen as being of particular interest in the securities industry as a new approach for recording assets on a non-centralised basis (i.e. in a distributed and opened manner). See, for example, Discussion Paper, *The Distributed Ledger Technology Applied to Securities Markets* (ESMA/2016/773, 2 June 2016). However, this new technological setting, which has its own challenges (such as integrity or safety of information technology systems) should in any case comply for the most part with the basic principles and rules that are provided for in the Convention.

C. Terminology

70. The Convention's core and functional harmonisation approach is readily apparent when examining the terminology adopted by the Convention's drafters. Article 1 of the Convention sets forth definitions for terms used in the Convention and comprehensive explanation of those terms is provided in the OFFICIAL COMMENTARY. The Guide adopts that terminology as well and, for ease of reference, the following key terms are briefly described below and together with other important terms in the Glossary:

- *Securities*: This term is defined in Article 1(a) of the Convention as "any shares, bonds or other financial instruments or financial assets (other than cash) which are capable of being credited to a securities account and of being acquired and disposed of in accordance with the provisions of th[e] Convention." That broad definition covers any financial assets which meet the two functional criteria of being able to be held in the intermediated holding system and to be governed by the Convention. But it does not cover cash (e.g. money deposited with a bank) or certain types of financial assets, including some categories of derivatives, as they do not meet those requisite criteria.
- *Securities account*: This term is defined in Article 1(c) as "an account maintained by an intermediary to which securities may be credited or debited". That definition applies, for example, to accounts maintained by an intermediary in the name of a natural or legal person who is not an intermediary; by an intermediary in the name of another intermediary; by a CSD in the name of an intermediary; or in a transparent system, by a CSD in the name of a natural or legal person (which may be an intermediary that in another capacity holds intermediated securities for its own account). It does not apply, however, to accounts maintained directly by issuers in the name of their shareholders or bondholders, or to issuer accounts (or registers) maintained by CSDs or other persons such as transfer agents on behalf of issuers.
- *Account holder*: This term is defined in Article 1(e) of the Convention as "a person in whose name an intermediary maintains a securities account, whether that person is acting for its own account or for others (including in the capacity of intermediary)". That definition covers both investors and intermediaries, as intermediaries may be account holders who hold securities with a higher-tier intermediary in its own account or on behalf of their account holders. In defining the term "account holder" in this way, it was unnecessary to include a definition of the term "investor" and, from this point forward, the Guide generally uses the term "account holder". Even the ultimate account holder at the end of the chain, moreover, may not be an investor. See paragraph 84 below. Even though the term is in the singular, it does not purport to prohibit a securities account from being maintained for several persons acting jointly.

- *Intermediary*: This term is defined in Article 1(d) of the Convention as “a person (including a [CSD]) who in the course of a business or other regular activity maintains securities accounts for others or both for others and for its own account and is acting in that capacity”. Intermediaries are usually entities such as banks, brokers, central banks and similar persons that maintain securities accounts for their account holders. In some systems, for example, an intermediary may be referred to as an account operator or account provider. Because of the functional definition, virtually any natural or legal person is covered provided that it maintains securities accounts for others in the course of its business. CSDs, which are specifically mentioned but not defined, are intermediaries only in relation to their participants (i.e. their account holders) but not in relation to the issuer.
- *Securities clearing system (SCS)*: This term, which is defined in Article 1(o) of the Convention, refers to market infrastructures facilitating and enhancing the efficient settlement of securities transactions among intermediaries. See paragraph 21 above and the Glossary. They are, in particular, market infrastructures, such as CCPs or clearing houses, that perform clearing functions (and possibly other functions not covered by the Convention), but not settlement.
- *Securities settlement system (SSS)*: This term, which is defined in Article 1(n) of the Convention, refers to market infrastructures permitting the efficient transfer of securities and funds among intermediaries, in particular by settling them or by clearing and settling them. See paragraph 21 above and the Glossary.
- *Issuer*: This term is not defined in the Convention, as it is understood to refer to a government or company which issues securities. See paragraph 22 above.

D. Scope

71. Further to the harmonisation approach adopted by the Convention’s drafters, the Convention’s scope of application is limited to only core aspects of intermediated securities holding and transfer. In this regard, the Convention’s definitions play a key role in establishing the Convention’s scope. As noted in paragraph 70 above, the Convention applies to “securities” which are capable of being credited to a “securities account” and of being acquired and disposed of in accordance with the Convention’s provisions. As the Convention does not specify a list of securities falling within its scope, it therefore allows for the evolution of market practice and the creation of new types of securities capable of being held in the intermediated holding system. For further discussion of what types of securities fall within the Convention’s scope, see OFFICIAL COMMENTARY, paragraph 1-10 et seq.

72. The Convention, however, generally excludes the area of law usually (but not necessarily) called corporate law (see Article 8), in particular the relationship between issuers and account holders. While the Convention generally does not cover this area of law, there are a few exceptions, specifically minimal provisions necessary to ensure integrity and achieve compatibility of intermediated securities holding systems around the world.

73. Like so-called corporate law, other legal and regulatory aspects fall outside the scope of the Convention. In other words, such aspects are to be addressed by each Contracting State’s legal and regulatory system. The only constraint is that such aspects must be addressed in ways which do not contravene the Convention’s provisions.

E. Law outside of the Convention

74. As the Geneva Securities Convention addresses the core issues necessary for achieving internal soundness and compatibility in a functional way, there are various matters that are to be addressed by law outside the Convention. In implementing the Convention, States thus retain significant legal and regulatory space, and there are important policy decisions to be made. There are three particular aspects to the way in which the Convention deals with law outside the Convention.

75. First, the Convention contains express references to law outside the Convention. Such references include the following:

- *Non-Convention law:* This term, which is defined in Article 1(m), refers to substantive law in relation to intermediated securities (other than the Convention) of the Contracting State. In many instances, the non-Convention law is to work as a complement to a Convention rule. A list of references to non-Convention law is included in Annex 2.
- *Applicable law:* This term refers to the law applicable by virtue of the private international law rules of the forum. The applicable law may, or may not, be the law of a Contracting State to the Convention (i.e. the non-Convention law). A list of references to applicable law is included in Annex 3.
- *Insolvency rules:* Insolvency law would be part of the non-Convention law or the applicable law, but insolvency is dealt with as a separate category because the commencement of an insolvency proceeding may trigger the mandatory application of special rules of law of the jurisdiction in which those proceedings are conducted that displace, or deviate from, the rules that would otherwise be applicable. A list of references to insolvency rules is included in Annex 4.
- *Uniform rules of securities clearing systems (SCSs) and securities settlement systems (SSSs):* The term “uniform rules” is defined in Article 1(p) as rules of an SCS or SSS which are common to the participants or to a class of participants and are publicly accessible. Such rules may derogate from or supplement the Convention’s rules. While Contracting States may only have limited or indirect influence over the rules of SCSs and SSSs, as they are typically private entities, Contracting States generally regulate such entities. Through such regulation, for which the Convention provides no rules, Contracting States could influence the content of these rules. A list of references to uniform rules of SCSs and SSSs is contained in Annex 5.

76. Second, there are references for which Contracting States, in properly implementing the Convention, have to make a declaration. The system of declarations provided for under the Convention gives Contracting States the possibility of making choices regarding these matters so as to achieve the policy objectives that they see fit in respect of intermediated securities and facilitate the coordination between the Convention’s provisions and their legal systems, which may follow one or more of the general models discussed in Part I.B. The system of declarations also provides the necessary flexibility to accommodate technological developments and evolutions in those models and legal systems. Model declaration forms are included with the Explanatory Memorandum for the Assistance of States and Regional Economic Integration Organisations on the System of Declarations under the Geneva Securities Convention, known as the Declarations Memorandum, which was issued by UNIDROIT in its capacity as Depository for the Convention and is available on UNIDROIT’s website (UNIDROIT 2012 – DC11/DEP/Doc. 1 rev.).

77. For example, the Convention applies, in principle, to any securities account maintained by an intermediary. Article 5 of the Convention, however, permits a Contracting State to limit by declaration the Convention’s scope of application to the securities accounts maintained by “regulated” intermediaries or those maintained by a central bank. The purpose of this rule is to offer States the possibility of excluding application of the Convention to securities accounts maintained by “unregulated” intermediaries, if and to the extent Contracting States would deem such exclusion appropriate. For more information on the optional declaration under Article 5, including a model declaration form, see the Declarations Memorandum, Section 4.B and accompanying Form No. 2.

78. Third, there are other particular matters, including in the field of corporate and regulatory law, which could have been addressed in the Convention, but were not due to the core and functional harmonisation approach adopted. Such matters are also to be taken into account, to the extent necessary, by law outside the Convention.

79. Law outside the Convention, in particular these three aspects, is addressed in the following Parts of the Guide, which *inter alia* offer guidance on the important policy choices to be made in creating an intermediated securities holding system or evaluating an existing one.

III. RIGHTS OF ACCOUNT HOLDERS AND DUTIES AND LIABILITIES OF INTERMEDIARIES

80. This Part and those that follow identify principles and rules capable of enhancing holding and transfer of intermediated securities and explain their interaction with law outside the Convention. To do so, each of these Parts identifies legislative principles which generally summarise, as applicable, what is covered by the Convention and what is to be addressed or clarified in creating or evaluating an intermediated securities holding system. The legislative principles, in addition to appearing in boxes throughout the remainder of the Guide, are also set forth together in Annex 1.

81. Following the legislative principles, each of these Parts then reviews the core Convention principles and rules and, as necessary, discusses the choices to be made by declaration and the matters to be addressed or clarified. This Part, in particular, addresses (a) the rights of account holders, (b) measures to enable the exercise of rights of account holders, and (c) liability of intermediaries.

A. Rights of account holders

Legislative Principle #1: The Convention provides any account holder with a core set of rights resulting from the credit of securities to a securities account. The law should establish additional rights consistent with how it characterises the legal position of account holders. It may distinguish between the rights enjoyed by an investor (including an intermediary acting for its own account) and those accruing to an intermediary acting in its capacity of intermediary.

1. Core Convention principles and rules

82. The core principles and rules are the following:

- All account holders have the right to dispose of the securities credited to their securities account and, to the extent it is permissible and feasible, the right to hold the securities otherwise than through a credit to their securities account. Article 9(1)(b)–(c).
- In addition to these rights, the ultimate account holder must receive and be able to exercise all the rights attached to the securities. Article 9(1)(a)(i).
- The non-Convention law may provide additional rights to all account holders, or to some of them. Article 9(1)(a)(ii) and 9(1)(d).
- The non-Convention law determines the limits to the rights above when the credit in a securities account provides the account holder with a security interest or another limited interest. Article 9(3).

83. In the intermediated securities holding system, securities are represented by credits made in the securities accounts maintained by the intermediaries at each level of the holding chain. A credit may also represent a security interest or another limited interest.

84. At the bottom of the holding chain is an account holder, who is not acting as an intermediary and is referred to as the ultimate account holder. The ultimate account holder may be:

- (a) an investor acting for its own account;
- (b) a secured party holding the intermediated securities as a result of a transaction involving a security interest;

(c) the beneficiary of a limited interest, such as an usufruct, other than a security interest; or

(d) a person holding intermediated securities as a fiduciary, such as an agent, a trustee, etc.

85. Article 9 defines two basic packages of rights resulting from a credit of securities to a securities account (hereafter: a credit), one for the ultimate account holder, and a less extensive one for other account holders. Under the Convention, the difference between the two packages is the rights attached to the securities, which must accrue to the ultimate account holder, but not necessarily to the intermediaries in the chain.

86. Depending on how non-Convention law characterises intermediated securities, it may extend each package accordingly. Similarly, non-Convention law may restrict such packages in line with the types of limited interests it allows the parties to create.

2. Choices to be made by declaration

87. The Convention neither requires nor permits declarations in respect of the matters discussed in this section.

3. Matters to be addressed or clarified

88. The following matters are to be addressed or clarified. First, the law should supplement the rights accruing to account holders in a manner consistent with its own characterisation of an account holder's legal position. See Article 9(1)(a)(ii) and 9(1)(d). In so doing, it may distinguish between the legal position of the ultimate account holder and the legal position of account holders acting as intermediaries in the chain. Second, the law should clearly define which limited interests may be granted in intermediated securities, and how these interests limit the rights of account holders. Article 9(3). Third, the law should also accommodate cross-border situations, where a domestic intermediary holds securities through a securities account with another intermediary in another jurisdiction, and thus likely holds under some foreign law.

a. Rights accruing to account holders

89. There is a necessary relationship between:

(a) the characterisation of intermediated securities and the additional rights conferred by the non-Convention law on all or certain account holders; and

(b) the types of security interests and other limited interests allowed by the non-Convention law and the restriction it imposes on the rights of an account holder when the credit represents such a limited interest.

Notably, the ensuing discussion elaborates upon this relationship, in particular using diagrams 90-1 and 92-1, which go beyond the basic static models set forth in Part I.B and show alternative ways rights and interests flow through intermediated securities holding chains.

90. For example, most legal systems of the civil law tradition consider the ultimate account holder to have a proprietary interest over the (certificated or uncertificated) securities held at the very top of the holding chain. Ultimate account holders are the "owners" or "co-owners" of the securities as well as the creditors (or right holders) against the issuer. Such systems see the intermediaries as depositories and book-keepers. Unless an intermediary has obtained a security interest, it does not have any proprietary interest over the securities themselves. Intermediaries do not receive or exercise the rights attached to the securities, except where this is necessary to pass such benefits down the chain all the way to the ultimate account holder.

Diagram 90-1: Flow of specific rights and interests in the individual ownership and co-ownership models

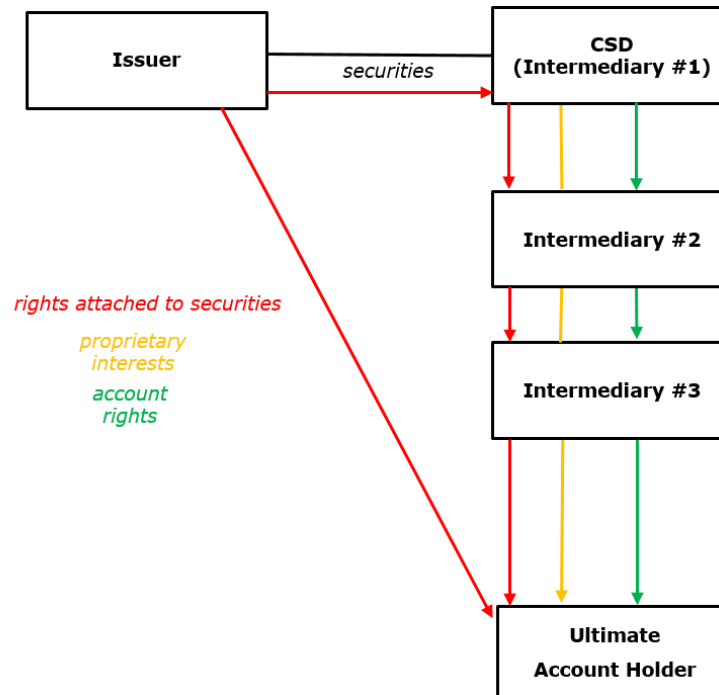

91. In such legal systems, the non-Convention law would typically use Article 9(1)(d) to confer on the ultimate account holder a proprietary interest over the securities. The holder of a limited interest would also be recognised as having a (limited) proprietary interest over the same securities. In respect of Article 9(1)(a), intermediaries may be authorised to receive and exercise the rights attached to the securities registered in the name of the investor. Similarly, for unregistered (bearer) securities, intermediaries may receive and exercise the rights attached to the securities, subject to an obligation to pass such benefit to their own account holder.

92. Other legal systems, typically of the Anglo-American tradition, characterise the legal position of each account holder as including a proprietary interest in the securities or intermediated securities held by the relevant intermediary. In some systems, this is based on a cascade of trusts. The upper-most intermediary holds the securities in trust for its account holders. These account holders, who are usually second-tier intermediaries, are the beneficiaries of this trust. The credit of securities in their securities account represents their beneficiary interest under the trust. They in turn hold this beneficial interest in trust for their own account holders, and so on. In some other systems, the credit of securities to a securities account creates a security entitlement. What these systems have in common is that each intermediary has a proprietary interest in certain assets (e.g. securities, beneficiary interest under a trust, security entitlement) and creates a distinct proprietary interest when it makes a credit to the securities account it maintains for a client.

Diagram 92-1: Flow of specific rights and interests in the trust and security entitlement models

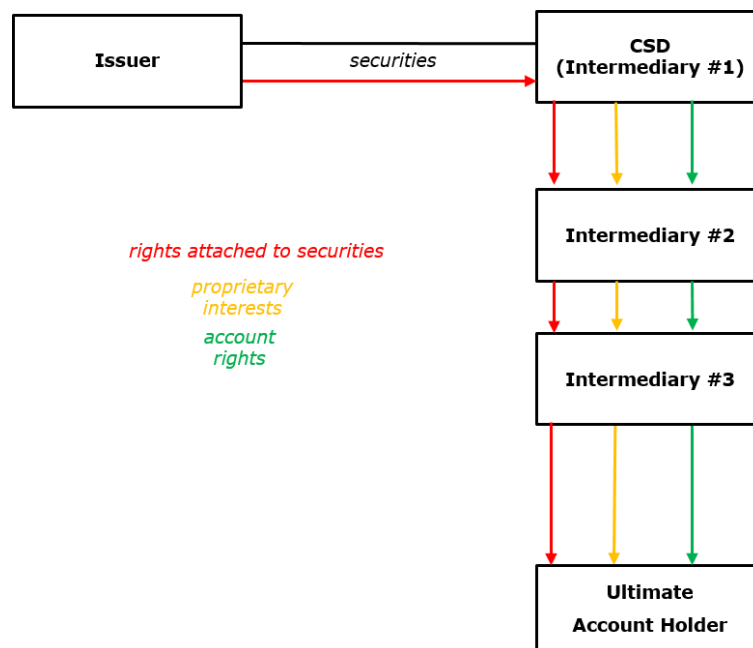

93. In this second group, in accordance with Article 9(1)(a)(ii), the non-Convention law would provide for each intermediary to receive the rights attached to the securities and pass these benefits to its own account holders, so that they finally reach the ultimate account holder. It would also define and characterise the rights (benefit of a trust, security entitlement, etc.) each account holder obtains in addition to the rights conferred by the Convention. Article 9(1)(d).

b. Limited interests

94. As discussed below in paragraphs 131 and 158, the Convention provides various methods for the granting of any type of security interests and other limited interests in intermediated securities, but does not prescribe which types may be so granted. It is entirely for the non-Convention law to define the types of (consensual and non-consensual) interest that can be granted (e.g. pledge, lien, charge, title-transfer security interest, usufruct, etc.).

95. The non-Convention law may refer this matter to its general provisions governing other types of assets (e.g. movable assets, intangible assets, etc.).

96. Alternately, the non-Convention law may define one or more types of limited interests that would apply exclusively to intermediated securities.

97. One way or the other, when drafting or reforming the non-Convention law in this area, lawmakers should be aware that limited interests are likely to limit the rights that arise from the credit of securities to a securities account. For example, if the account holder is the pledgee of the securities credited to its securities account, the non-Convention law regulating pledges is likely to limit the right to dispose of the intermediated securities to certain circumstances. It may also determine whether the pledgee can exercise the voting rights attached to the securities.

c. Cross-border situations

98. When drafting or revising law governing intermediated securities, lawmakers should design the bundle of rights created by a credit to a securities account in a manner consistent with that jurisdiction's characterisation of the rights of investors, collateral takers and other account holders. Top-down consistency may be achieved for holding chains which are purely domestic, from the upper-most to the last intermediary in the chain. However, this is unlikely to be the case where the holding chain begins or ends in another jurisdiction. This is due to the different characterisations (and bundles of rights) that this or these other jurisdictions may attach to a credit of securities.

99. Lawmakers should be aware of this frequent inconsistency in cross-border holding chains, which is inherent in a global intermediated securities holding system. Because non-Convention law differs from one jurisdiction to another, and because it generally provides rights in addition to Convention rights, it is likely that the rights resulting from a credit of securities with intermediary #1 in diagram 99-1 below are different from the rights resulting from a credit of the same securities with intermediary #2. While the non-Convention law applicable to intermediary #2 cannot unilaterally expand its application to intermediary #1, it can secure the position of account holders by providing that, in cross-border situations, an account holder not only has the rights it enjoys under the non-Convention law of State B, but enjoys any additional rights that the relevant intermediary (here: intermediary #2) obtains from its own intermediary at the upper level (here: intermediary #1), provided that the exercise of such rights by the foreign account holder would be recognised by the non-Convention law of State A.

Diagram 99-1: Different States laws in a cross-border intermediated securities holding chain spanning two States

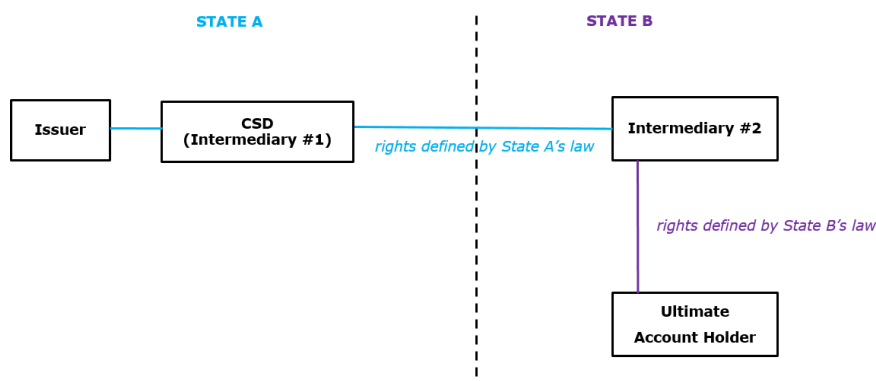

B. Measures to enable the exercise of rights of account holders

100. The Convention provides that certain rights of account holders may be exercised only against the intermediary. Article 9(2)(c). However, because the Convention does not make any assumption about the legal structure and characterisation of proprietary interests in intermediated securities, it does not determine whether the rights attached to the securities can or must be exercised by the account holder against its own intermediary (“through the intermediated chain”) or directly against the issuer. See Article 9(2)(b). This is why the law should clearly define the persons entitled to exercise the rights attached to the securities vis-à-vis the issuer and the conditions thereof. See paragraph 245 et seq. below.

101. Even when an account holder may or is required to exercise the rights attached to the securities against the issuer, it often must rely on the assistance of the intermediary chain. In many respects, intermediaries must enable account holders to exercise their rights. They have corresponding duties and liabilities, which are only partially laid down by the Convention. In this area, as in many others, the Convention leaves broad space for non-Convention law.

Legislative Principle #2: The Convention provides one general and four specific obligations of intermediaries to their account holders. The law should establish specific contents for these duties and, if necessary, expand them in a manner consistent with its own characterisation of an account holder’s legal position. The law should also specify the manner in which an intermediary may comply with its obligations and determine the conditions under which an intermediary becomes liable. In transparent systems, where intermediary functions are shared between the CSD and account operators, the law should clearly allocate the respective responsibilities, and the Contracting State must make a declaration in this respect.

1. Core Convention principles and rules

102. The core principles and rules are the following:

- An intermediary must generally take all appropriate measures to enable its account holders to receive and exercise their rights. Article 10(1).
- An intermediary must protect securities credited to a securities account. Articles 10(2)(a) and 24.
- An intermediary must allocate securities or intermediated securities to the rights of its account holders so that they cannot be reached by the intermediary's creditors. Articles 10(2)(b) and 25.
- An intermediary must give effect to authorised instructions. Articles 10(2)(c) and 23.
- An intermediary must not dispose of securities credited to a securities account without an authorised instruction. Articles 10(2)(d) and 15.
- An intermediary must regularly pass on information necessary for the exercise of rights, dividends and other distributions. Articles 10(2)(e)-(f).
- An intermediary may not exclude liability for its gross negligence or wilful misconduct. Article 28(4) and see paragraphs 120 et seq. below.

2. Choices to be made by declaration

103. For transparent systems, where some functions of the relevant intermediary (usually the CSD) are performed by other persons often called account operators, Article 7 requires the Contracting State to make a declaration. In particular, it requests the Contracting State to:

- (a) identify by name or description the CSD (or the relevant intermediary) on one hand, and the persons who are responsible for the performance of some intermediary functions on the other;
- (b) specify the functions for which these persons are responsible and the Convention provisions that apply to them; and,
- (c) where applicable, specify the categories of securities to which this function sharing applies.

104. In such transparent systems, the core principles and rules summarised in paragraph 102 do apply to the CSD (or the relevant intermediary) and to the other persons in accordance with the sharing of functions described in paragraph 103. For more information on Article 7 and the optional declaration thereunder, see paragraphs 206-207 below.

105. The Convention neither requires nor permits any other declaration in respect of the matters discussed in this section.

3. Matters to be addressed or clarified

106. The following matters are to be addressed or clarified by law outside the Convention. First, the law should determine the extent of information that an intermediary must regularly pass on to account holders relating to intermediated securities and to what extent an intermediary must pass on to account holders any distribution received in relation to intermediated securities. Articles 9(1)(a)(ii) and 10(2)(e)-(f). Second, more generally, the law should determine how an intermediary must enable account holders to exercise the rights (if any) that they are entitled to exercise vis-à-vis the issuer. Article 9(1)(a). Third, the law should specify when a personal representative (such as the guardian of a minor, the administrator of an estate or an insolvency, etc.) may give instructions in lieu of the account holder. Article 23(2)(d). Fourth, the law may impose additional duties on intermediaries as required to support the exercise of account holders' rights and should specify the manner in which intermediaries may comply with their legal and Convention duties. Article 28(1)-(2).

107. In transparent systems, moreover, law outside the Convention should clearly allocate all those duties between the CSD and the account operators who are responsible for the performance of some intermediary functions.

108. At the outset, it is worth noting that, in the provisions discussed in this section, the Convention refers generally to the non-Convention law and, to the extent allowed by the non-Convention law, to the account agreement between the intermediary and the account holder or to uniform rules of a SSS. See generally Part V.C below. It is impossible for legal provisions to cover the entirety of the operational obligations of an intermediary. It is thus quite frequent that legal provisions are supplemented by contractual provisions in the account agreement, and it is always the case that uniform rules of settlement systems contain extensive and minute prescriptive provisions regulating the respective obligations of the operator and the participants to the system.

109. One should also keep in mind that law outside the Convention, including the term “non-Convention law”, not only refers to statutory instruments but also to decrees and regulations. In most systems, the duties of intermediaries are the subject matter of a more or less extensive set of statutory provisions supplemented by sometimes extensive regulations of a technical nature issued by a ministry, a regulatory agency or the central bank within the framework of their respective regulatory powers.

a. Passing on information and distributions received

110. For unregistered (bearer) securities, and often for registered securities (where the shareholder or bondholder is identified in a register maintained by or on behalf of the issuer), information and payments provided by the issuer to the securities holders will actually go down through the chain of intermediaries. Other “corporate actions” may require or enable the account holder to declare choices (such as providing voting instructions concerning resolutions proposed to the general meeting, accepting a tender offer, exercising an option, etc.), which must be passed up the holding chain. It is generally so that the law affirms a duty on each intermediary to pass on such information, distribution or declaration, but leaves the particulars to be regulated in the account agreement.

111. The duty to pass on distributions needs some qualifications. There may be several reasons why a payment received directly or indirectly from the issuer by an intermediary should not be transferred to the account holder, such as when the intermediary itself or a third party has a security interest in the intermediated securities.

b. Enabling the exercise of other rights against issuer

112. Many rights attached to the securities cannot merely be passed on to the account holder. To exercise such rights, the account holder must make a choice or a declaration such as issuing a vote or giving a power to vote to another person. Or the account holder may need to take an action such as filing a claim in the issuer’s bankruptcy or filing a derivative suit against the issuer’s directors. In most cases, the account holder will need the assistance of the relevant intermediary (and possibly other intermediaries in the holding chain) to convey its declaration to the issuer or to certify its position as a shareholder or bondholder.

113. While it is unlikely that all situations can be anticipated, the law should deal with the most common situations and possibly lay out a general principle or test to solve other situations as they may come. More specific provisions in account agreements or in the uniform rules of a SSS could supplement the legal provisions. For various reasons, including to reduce risks inherent in holding chains, the law might be permit a foreign intermediary to hold in an intermediated holding system without the necessity of holding through a local intermediary.

c. Giving effect to authorised instructions

114. First and foremost, an intermediary owes its duties to the account holder, who is generally authorised to give instructions for the intermediary to take action. Under certain circumstances, however, another person may give binding instructions to the intermediary. That person’s power to give instructions may be additional to the general power of the account holder, or it may limit (e.g. when the other person has

negative control – see paragraph 146 below – over intermediated securities as the result of an interest granted to it) or exclude (e.g. when the account holder is legally incapacitated) the validity of instructions given by the account holder.

115. Article 23(2) contemplates situations in which another person is authorised to give instructions to the intermediary. The list includes persons to whom an interest has been granted in the intermediated securities; a person who has power to give an instruction under the account agreement or the uniform rules of a SSS; and a court or administrative authority empowered by law to issue an order in respect of intermediated securities.

116. Many other situations are not contemplated by the Convention but derive from general principles or specific rules of the non-Convention law. They may include the power of a guardian over the assets of its pupil, an executor over the assets of an estate, an insolvency administrator over the assets subject to the insolvency; the power of directors or officers of an issuer; powers of attorney; etc.

117. The law should therefore clarify generally or by specific provisions which and when such powers are effective against an intermediary and to what extent such powers displace the account holder's own power to give instructions.

d. Specifying the manner of complying with Convention obligations

118. The general duty of intermediaries to enable the exercise of their account holders' rights and the four specific obligations laid down by the Convention are expressed in general terms. This may create a degree of uncertainty for intermediaries. To reduce this uncertainty, Article 28(1) provides that the non-Convention law may specify the content and the manner in which an intermediary complies with its Convention obligations. The law may alternatively allow such issues to be specified in the account agreement or, where applicable, in the uniform rules of a SSS. One should keep in mind that any reference to the law is not limited to statutory instruments but includes regulations as well.

119. Article 28(2) states that, where an intermediary complies with a provision of non-Convention law – or alternatively the account agreement or uniform rules of a SSS to the extent permitted by such law – that specifies the substance of an obligation under the Convention, it satisfies the Convention obligation. However, such law cannot make the Convention obligation so minimal that it amounts to no obligation in substance. See OFFICIAL COMMENTARY, paragraph 28-14.

C. Liability of intermediaries

Legislative Principle #3: The Convention does not specify the liability of intermediaries. The law should clearly establish the conditions and the extent of such liability, and whether it may be exempted by way of contractual provisions.

120. The Convention does not set out the conditions under which an intermediary becomes liable to its account holders or to other persons. Article 28(3). Non-Convention law should therefore determine the conditions and the effects of a breach of duty by an intermediary. It may do so by providing a set of rules specific to the functioning of the intermediated holding system, or by referring to its general provisions and, where necessary, supplement or modify them to reflect adequately the specificities of the system.

121. Non-Convention law should specify whether that liability may be modified or excluded by the account agreement or by the uniform rules of a SSS. That law, however, cannot derogate from Article 28(4), which states that an intermediary may not exclude liability for its gross negligence or wilful misconduct.

122. Of particular concern is the liability of an intermediary for a failure by its (own) relevant intermediary or other intermediaries (which, as noted in paragraph 29 above, may be referred to as "sub-custodians") in a holding chain. Where holding chains involve several intermediaries and, in particular, cross national borders, an account holder may be exposed to risk and loss due to the actions or omissions of intermediaries with which it has no direct relationship. The non-Convention law should address these risks by setting, at

a minimum, a duty upon a relevant intermediary to use care in the selection and monitoring of intermediaries that it employs. But the non-Convention law might set upon intermediaries duties (and corresponding liability) beyond such a duty of care. Such law, for example, might require a relevant intermediary to ensure that its account agreements with other intermediaries impose on those intermediaries duties not less protective than those the relevant intermediary has assumed under the non-Convention law and the account agreement with respect to its account holders. It might reach even further by requiring this other intermediary to impose similar duties on its own upper-tier intermediaries. As a practical matter, however, States should proceed with caution so as not to restrict unduly, geographically or otherwise, the investments that account holders could feasibly acquire.

IV. TRANSFER OF INTERMEDIATED SECURITIES

123. The ability to buy and sell intermediated securities and create and grant interests in them is essential to the functioning of capital markets. To promote the sound functioning of markets, as set out in this Part of the Guide, States should establish or revise their laws consistent with the following principles, rules, and related guidance on transfer of intermediated securities, in particular regarding (a) acquisition and disposition of intermediated securities, (b) unauthorised dispositions and reversal, (c) protection of an innocent acquirer, and (d) priorities.

A. Acquisition and disposition of intermediated securities

Legislative Principle #4: The Convention provides that intermediated securities or any limited interests therein may be transferred by debits and credits. The law also may adopt any one or more of the other methods specified by the Convention.

124. The transfer of intermediated securities and any limited interests (e.g. security interests) may occur by various methods. Some methods for transfer rely on book-entries in securities accounts, such as the debit and credit method and the designating entry method. Not all methods for transfer, however, require such entries. This section deals with transfer by the debit and credit method and by other methods.

1. Transfer by debit and credit method

a. Core Convention principles and rules

125. The core principles and rules are the following:

- Intermediated securities are acquired when a credit is entered in the securities account of the transferee, and they are disposed of when a debit is made to the securities account of the transferor. Article 11(1) and 11(3).
- Limited interests in intermediated securities, such as security interests, may also be transferred by debit and credit entries in the securities accounts of the transferor and the transferee respectively. Article 11(4).
- No further steps, such as publicity or registration requirements, are necessary to make such acquisition effective against third parties. Article 11(2).

126. As intermediated securities exist as book-entries in securities accounts, debits to the transferor's account and credits to the transferee's account play an essential role in intermediated holding systems. Such debits and credits, however, do not occur in a void as they are based on the transactions agreed between the transferors and the transferees and generally result from instructions issued by them to their respective intermediaries. Based on that transaction and the underlying interests transferred, the debits and credits may represent the transfer of a full interest in intermediated securities or a limited one.

127. Debits and credits have become the universal method for transferring intermediated securities. As a result, the Convention requires that this method of transfer be available to all account holders. The

Convention further requires that, as discussed in Part IV.B, a debit be authorised by the account holder and, to ensure legal certainty for transferees against third parties, no further step may be necessary to render that transfer effective.

128. Apart from these core harmonising rules, because of the diversity of legal rules and operational systems in intermediated holding worldwide, the Convention leaves to non-Convention law various important issues, which are discussed below.

b. Choices to be made by declaration

129. The Convention neither requires nor permits declarations in respect of the matters discussed in this section.

c. Matters to be addressed or clarified

130. The following matters are to be addressed or clarified. First, the law should determine whether a “no credit without debit” rule, whereby any credit to a securities account must have a corresponding debit to another securities account, is to apply to transfers by this method. Second, the law should also determine whether to permit net settlement of intermediated securities transactions. Article 11(5). Third, consideration should be given to whether the law should determine what constitutes a debit and a credit.

131. Relatedly, what limited interests may be transferred by a credit to a securities account is entirely for the non-Convention law to determine, as the Convention is silent in this regard. See paragraphs 94-97 above. In addition, although no further steps may be required for effectiveness against third parties, the law should clearly define when a debit or credit is valid and when a debit is or can be made conditional. Articles 11(1)-(2) and 16 and see paragraphs 165-168 below.

(i) The connection between debits and credits

132. The connection between debits and credits is an area of significant divergence between various domestic legal and regulatory regimes. Most legal systems of the civil law tradition, for example, follow the “no credit without debit” rule and consider that the intermediated securities debited from the transferor’s account are the very same ones that are credited to the transferee’s account. In other words, in a given securities transaction, the equivalent property that is relinquished by the transferor is acquired by the transferee and the book-entries for that transaction should occur at the same time, though this does not always occur in practice. If not simultaneous, the law ensures that there is a single conceptual instance for the acquisition and disposition and that any mismatch between the relevant securities accounts is resolved as soon as possible. It may also provide that the credit to the transferee’s account prevails over any remaining credit to the transferor’s account.

133. Legal systems of the common law tradition, however, do not necessarily make such a connection. In a trust system, for example, account holders acquire an equitable interest in the assets held by their intermediary as beneficiaries of a trust. When an account holder sells securities, that account holder is not legally transferring its equitable interest to the transferee. Instead, that equitable interest – derived from the intermediary’s holding – is extinguished, and a comparable interest is created by the transferee’s intermediary for the transferee. In a security entitlement system, as another example, a similar analysis applies. The transferor’s entitlement with its intermediary is extinguished, and another entitlement is created by the transferee’s intermediary for the transferee.

134. The Convention fully defers on these issues and, depending on how intermediated securities are characterised (see paragraph 85 et seq.), the non-Convention law should determine whether a “no credit without debit” rule is to apply.

(ii) Debits and credits on a net basis

135. As noted in paragraph 20 above, where multiple transactions are made every day, it makes sense not to transfer gross quantities per transaction but, where possible, to net transfer obligations at

predetermined times and to transfer only the resulting net amount. In systems in which net settlement of intermediated securities transactions is permitted, to the extent that there are matching debits and credits to accounts maintained by the intermediary for its account holders, there need not be precisely matching entries in the intermediary's accounts maintained with its upper-tier intermediary. Such entries, however, should simply reflect the net overall change in the aggregate balance of its account holders taken together.

136. The Convention does not mandate recognition of netting arrangements. See Article 11(5). Non-Convention law thus may allow or disallow debits and credits to be made on a net basis in the accounts of an intermediary with an upper-tier intermediary to reflect, for securities of the same description, the net result of all movements in the accounts maintained by that intermediary for account holders and its own holdings. Such law should address and determine whether to provide for recognition of netting arrangements.

(iii) *Definition of debit or credit*

137. It is for the non-Convention law to determine what constitutes entries such as debits and credits as the Convention is silent in this regard. Such a definition, if necessary, may be found in some legal or regulatory provisions of the non-Convention law or, possibly, in the uniform rules of an SSS.

2. Transfer by other methods

a. Core Convention principles and rules

138. The core principles and rules are the following:

- The Convention expressly recognises three optional additional methods for an account holder to transfer intermediated securities or any interest therein.
- An account holder may grant an interest by entering into a valid agreement with its intermediary (Article 12(3)(a)), with another person and by having a designating entry (earmarking) made in favour of that person in its security account (Article 12(3)(b)), or by entering into a valid control agreement with the intermediary that permits that person to exercise control over the securities (Article 12(3)(c)).
- For these methods, as for the debit and credit method, no further steps may be required for effectiveness against third parties. Articles 12(1)-(2). The non-Convention law should be reviewed to determine whether any further step or steps are required and, if any exist, they should be eliminated. As to the invalidity or reversal of a designating entry or other book-entry, see Article 16 and paragraphs 165-168 below.
- Other methods for transfer may be maintained in the non-Convention law. Article 13.

139. The Convention expressly provides four methods for transferring intermediated securities or any limited interests therein: the debit and credit method in Article 11 and three additional methods in Article 12. The three additional methods, although present to varying extents around the world, have not reached the same level of universal acceptance as the debit and credit method. Accordingly, under the Convention, the debit and credit method must be recognised, whereas the three additional methods are optional.

140. Apart from the methods expressly provided in the Convention, Contracting States are entitled to use additional methods under Article 13. Subject to certain limitations described below, Article 13 permits States to accommodate alternative methods for transfer (e.g. an existing one that a State may wish to retain) in that State's legal framework.

b. Choices to be made by declaration

141. Article 12 sets out a number of options with respect to the three additional methods, and States may wish to consider whether to provide for or retain one, two, all or none of these methods in their non-Convention law. The additional methods provided by Article 12 are the following:

(a) *Designating entry (or earmarking)*: besides a valid agreement between parties, this method requires a book-entry in favour of the transferee in the transferor's securities account, made by the relevant intermediary according to the transferor's instructions;

(b) *Control agreement*: a valid agreement between the parties is accompanied not by a book-entry in the transferor's securities account, but rather it directly states those conditions or obligations under which the relevant intermediary must act to the benefit of the transferee; and

(c) *Agreement with relevant intermediary (or automatic perfection)*: an interest is created when the account holder and its relevant intermediary enter into a valid agreement. There is no other condition to be met because the agreement binds the very same parties that would be needed for a control agreement, and the position of the intermediary is secured by the control it has over the securities account that it maintains for the account holder.

142. All these methods have in common that the intermediated securities in which interests are transferred remain credited to the transferor's securities account. Further, two steps are required for each: (a) the transferor and the transferee enter into a valid agreement regarding the interest to be granted; and (b) the condition specific to the relevant method is satisfied.

(i) Positive and negative control

143. Because designating entries are book-entries like debits and credits, they conform in many ways with this universal method for transfer and are preferred in many systems. The book-entry also serves as a form of publicity, but this is generally of very limited value because securities accounts are not public registries to be consulted without authorisation. Account statements, moreover, may become out of date within minutes of being generated.

144. Other systems prefer control agreements, which do not require a book-entry in the transferor's account and allow for contractual provisions regulating the relationship between the transferor, transferee and, in typical instances, the relevant intermediary.

145. As the intermediated securities in relation to which an interest is granted by designating entry or control agreement remain in the transferor's securities account, it is not enough that a book-entry be made or an agreement be in place reflecting the existence of that interest. That entry or agreement must also have certain effects protecting the transferee against possible unauthorised actions regarding the relevant securities.

146. For protection in this regard, non-Convention law is to determine whether a designating entry or a control agreement provides the transferee of the interest with "positive" or "negative" control, or both. Positive control requires the intermediary maintaining the transferor's account to comply with any instructions given by the transferee in relation to those intermediated securities as may be provided by the account agreement, control agreement, or the uniform rules of an SSS, without further consent of the transferor. Negative control requires that the intermediary maintaining the transferor's account may not comply with any instructions given by the transferor in relation to the relevant intermediated securities without the transferee's consent. See Articles 1(k) and 1(l).

(ii) Interests transferable by the three methods

147. In many systems, these three additional methods are typically used to transfer limited interests in intermediated securities, such as security interests. Like the debit and credit method, however, the three

additional methods may also be used to transfer intermediated securities as well as any limited interests therein, even though transferees of intermediated securities typically prefer to have them credited to their securities accounts.

148. Under the Convention, these three methods are not restricted to transferring limited interests, despite the fact that they are primarily used for doing so, because such a restriction would require defining the content of particular concepts, such as security interests. This would undermine the Convention's functional approach and interfere with the property notions of various domestic systems.

149. In line with commercial practices in numerous markets, Article 12(4) provides that any of these methods may be used to grant an interest in respect of:

(a) an entire securities account, so that it applies to all intermediated securities credited from time to time standing to the credit of that account; or

(b) a specified category of intermediated securities, or a specified quantity or value of intermediated securities, standing to the credit of a given securities account.

(iii) *Declarations*

150. What methods for transfer are available in which legal systems is important information for investors and intermediaries. This is why the Convention promotes the three optional methods (in addition to the debit and credit method). If a Contracting State wishes to adopt one or more of those methods, a declaration is required regarding which methods they have chosen and, if applicable, to specify the type of control resulting from a designating entry or control agreement.

151. A Contracting State may also limit via declaration the possibilities provided under Article 12(4). See paragraph 149.

152. The purpose of such declarations is to enhance international transparency and legal predictability, and they may be subsequently modified. For more information on these optional declarations under Article 12(5)-(7), see the Declarations Memorandum, Section 4.D and accompanying Forms No. 4A to 4F.

153. Furthermore, if a State chooses both designating entries and control agreements, it should also consider whether both methods rank equally or if an interest granted by a designating entry always has priority over an interest granted by way of a control agreement, in which case this should be the subject matter of a declaration. See Article 19(7) and paragraph 189 below.

c. *Matters to be addressed or clarified*

(i) *Valid agreement required*

154. Each of the three additional methods for transfer requires that the account holder enter into an agreement with or in favour of the person to whom an interest is granted. Non-Convention law determines the nature, scope, and extent of the interest granted, may establish formal requirements for such agreement, and may distinguish among classes of account holders. It also determines the consequences for an agreement that is invalid or ineffective for reasons such as lack of formality, lack of capacity, mistake, and illegality.

(ii) *Other methods for transfer under non-Convention law*

155. The four methods for transfer expressly identified in the Convention are not exclusive. Indeed, additional methods, as recognised by Article 13, are not precluded by the Convention. There are a number of policy choices to be made with respect to such non-Convention methods. States may wish to consider whether these aspects of intermediated securities law are to be standalone (with creation of special

methods) or part of existing laws or rules within their domestic system. States may preserve existing methods or consider other approaches to ensure effective transfers of interests.

156. Transfers according to such other methods are not eligible for the protection of an innocent acquirer under Article 18, though they may be protected by a similar provision of non-Convention law. See paragraphs 180-181 below. Their priorities are determined by the non-Convention law, except that they are subordinated to all interests that become effective against third parties under Article 12. See paragraphs 196-197 below.

157. A Contracting State should consider existing methods for transfer falling under Article 13 and whether they should be retained.

(iii) *Limited interests that can be granted*

158. What limited interests may be granted by a method under Article 12 is entirely for the non-Convention law to determine. For discussion, see paragraphs 94-97 above.

(iv) *Non-consensual security interests*

159. Article 12(8) references non-consensual security interests (e.g. statutory liens, purchase-money liens, etc.), which are not regulated by the Convention. Such interests arise, become effective against third parties and enjoy the priority determined by the applicable law. As discussed in paragraphs 192-195 below, States may wish to consider how these types of interests are addressed in their law.

B. Unauthorised dispositions and invalidity, reversal and conditions

Legislative Principle #5: The Convention provides that an intermediary may only dispose of intermediated securities with the authorisation of the person(s) affected by the disposition. The law may provide for other cases of authorised dispositions, and it should establish the consequences of unauthorised dispositions. The law should also determine whether and in what circumstances a book entry is invalid, reversible, or conditional, and the consequences thereof.

1. Core Convention principles and rules

160. The core principles and rules are the following:

- Debits of securities to a securities account, designating entries or the removal of designating entries or any other disposition of intermediated securities may only be made with the authorisation of the person(s) negatively affected by the disposition. Article 15(1)(a)-(d).
- Such authorisation may also be contained in the non-Convention law. Article 15(1)(e).
- The non-Convention law and, to the extent permitted by the non-Convention law, the account agreement or the uniform rules of a SSS determine the consequences of dispositions lacking the required authorisation. Article 15(2).
- This corresponds with the Convention's general rule that non-Convention law determines whether and in what circumstances a debit, credit, designating entry or removal of a designating entry is invalid, is liable to be reversed or may be subject to a condition, and the consequences thereof. See Articles 15(2) and 16.
- With respect to unauthorised designating entries, the consequences of unauthorised dispositions provided in the non-Convention law are subject to the protection of innocent acquirers. Article 18(2).

161. The general idea of Article 15 is that dispositions of intermediated securities must be authorised by the person(s) affected by those dispositions. Article 15(1)(a)-(d) specify such dispositions, including dispositions in accordance with Articles 11, 12 and 13, and the persons by whom the intermediary must be authorised. The prerequisites of a valid authorisation are not regulated by the Convention. But the authorisation itself may be given by any kind of express or implied consent under the Convention, including instructions of the affected person. Article 10(2)(c). The non-Convention law may additionally provide authorisation by operation of law and not by the affected person(s).

162. The consequences of unauthorised dispositions are deferred to non-Convention law. Dispositions under Article 15(1) are not necessarily associated with book-entries (e.g. Articles 12(3)(a), 12(3)(c), 13). But insofar as unauthorised dispositions implicate a (removal of a) book-entry in a securities account, Article 15(2) replicates the general rule that the validity, reversibility and conditionality of book-entries in securities accounts are determined by the non-Convention law. Article 16. The non-Convention law may permit that the account agreement or the uniform rules of a SSS also determine the consequences of unauthorised dispositions and whether book-entries are defective. Articles 15(2), 16, 17(d).

163. The relevance of the non-Convention law is subject to the protection of the innocent acquirer. Articles 15(2), 16, 18. The reason why only unauthorised designating entries are mentioned in Article 15(2) and expressly made subject to Article 18(2) is that only such book-entries may directly result in defective entries. In the case of other unauthorised dispositions, later resulting in a defective (credit or designating) entry, however, an innocent person may, by a subsequent transaction, also acquire an interest in intermediated securities free of adverse claims.

2. Choices to be made by declaration

164. The Convention neither requires nor permits declarations in respect of the matters discussed in this section.

3. Matters to be addressed or clarified

a. Defining authorisation of dispositions and the consequences of unauthorised dispositions

165. While the Convention states that an intermediary may only dispose of intermediated securities with the authorisation of the person affected by the disposition, the authorisation required by Article 15 may also be contained in (general provisions of) the non-Convention law.

166. The law should clarify the consequences of dispositions that are not authorised by the person who is negatively affected by the disposition. Article 15(2). The non-Convention law may defer this decision to the general provisions of its law, to the account agreement or the uniform rules of a SSS.

167. The non-Convention law may also regard such unauthorised dispositions neither as void nor as liable to be reversed but, for instance, as a mere breach of contract between the intermediary and the person affected by the unauthorised disposition.

168. To some extent, the consequences of unauthorised dispositions may be dependent on the intermediated securities holding model chosen by the respective State. See generally Part I.B above. For example, in the co-ownership system of a European civil law State, unauthorised debits are void, though the subsequent acquisition by an innocent person may be protected, having the result that the account holder of the wrongly debited securities account would lose its proprietary interest. In the security entitlement system of a North American common law State, unauthorised debits are also void, and the relevant intermediary is obligated to re-credit the securities account which was wrongly debited, thereby re-establishing that account holder's securities entitlement.

b. Clarifying validity requirements and conditions of book-entries

169. In general, the law should clarify whether and in what circumstances book-entries are void, are liable to be reversed or are conditional. Article 16.

170. The law should also address the consequences of the reversibility of unauthorised or defective (credit or designating) book-entries. In particular, the law has to determine whether the reversal of book-entries has retroactive effect or *ex nunc* effect. Likewise, decisions have to be made in case of conditional book-entries when the condition is not fulfilled. The non-Convention law may defer this decision to the general provisions of its law or to the account agreement or the uniform rules of a SSS. Articles 15(2), 16 and see paragraphs 132-134 above (regarding the “no credit without debit” rule).

171. The law has to make clear that the consequences of unauthorised dispositions and defective (credit or designating) book-entries that are determined by the non-Convention law are subject to the overriding principle of the protection of an innocent acquirer. Article 18 and see also Articles 15(2), 16.

C. Protection of an innocent acquirer

Legislative Principle #6: The Convention provides that an innocent acquirer who acquires for value is protected against adverse claims. This protection covers instances in which (a) another person has an interest in intermediated securities which is violated by the acquisition, and (b) the acquisition could be affected by an earlier defective entry. The law may extend the scope of this protection.

1. Core Convention principles and rules

172. The core principles and rules are the following:

- The innocent acquirer who acquires for value is protected against adverse claims. The innocent acquirer is protected if another person has an interest in intermediated securities which is violated by the acquisition. Article 18(1). The innocent acquirer is also protected against the invalidity or reversibility of an earlier defective entry. Article 18(2).
- With regard to earlier defective entries, the acquisition by an innocent person is, to the extent permitted by the non-Convention law, subject to the uniform rules of a SSS or the account agreement. Article 18(5).
- The Convention also protects against other claims (e.g. damages or unjust enrichment) that may be asserted against the innocent acquirer by the person who holds the right or interest or would otherwise benefit from the invalidity or reversal of the defective entry. Article 18(1)(c) and 18(2)(b).
- The protection of the innocent acquirer is limited to instances in which the acquirer has given (any kind of) value, which has to be understood in a broad sense. See Article 18(3) and OFFICIAL COMMENTARY, paragraphs 18-15 to 18-16.
- The priority of interests in the same intermediated securities is, however, not regulated by Article 18, but by Articles 19 and 20(2). See Articles 18(6) and 19 and paragraphs 182-188 below.

173. The general idea of Article 18 is not only to protect the innocent acquirer, but also to immunise onward transfers against the consequential risk of being removed or reversed based on another person’s interest in the intermediated securities or on an earlier defective entry. Article 17, for its part, provides definitions which are relevant for the operation of Article 18, including the following:

- (a) The term “acquirer” is defined in a broad sense, including the acquisition of a security interest or another limited interest. Article 17(a).

(b) The acquirer is innocent, unless the acquirer actually knows or ought to know, at the relevant time, of another person's interest or of an earlier defective entry. Considering the short time frame of transactions in intermediated securities that are effectuated through impersonal markets, an acquirer has no general duty of inquiry or investigation in order to meet the standard of innocence. See Article 17(b) and, as to the standard of "ought to know", OFFICIAL COMMENTARY, paragraphs 17-8 to 17-14.

(c) The question whether organisations actually know or ought to know of an interest or fact has to be determined by reference to the individual responsible for the matter to which the interest or fact is relevant. Article 17(c).

(d) A defective entry is a credit of securities or designating entry that is invalid or liable to be reversed. Article 17(d).

(e) The relevant time at which the acquirer must be innocent is usually the time that the credit is made. Article 17(e). Since interests in intermediated securities may become effective without a credit entry in the securities account, the relevant time is, in this case, determined by the time when those interests have been made effective against third parties. Article 19(3).

174. The protection of the innocent acquirer thus covers situations in which the other person's interest in the intermediated securities is violated by the acquisition. Article 18(1). Article 18(2) extends this protection to situations in which the earlier defective entry does not constitute an interest in the intermediated securities at the relevant time of acquisition, but bears the risk of resulting in the innocent acquisition being reversed. The scope of application of Article 18(1) and Article 18(2) may overlap.

175. As the results under paragraphs 1 and 2 of Article 18 are identical, the distinction between these paragraphs is usually not relevant. The protection under Article 18(1) is not subject to law outside the Convention. The protection under Article 18(2), however, may be subject to any provision of the uniform rules of a SSS or the account agreement. See Article 18(5).

176. The function and meaning of Articles 18(1) and (2) depend on the (general) provisions of the law of the respective State for two reasons. First, Article 18(1) protects an innocent acquirer of intermediated securities against any competing claim from another person and ensures that he or she may acquire the securities even if a corresponding debit has not been made. This is relevant even in a so-called matching system (i.e. a system in which credit entries have to correspond with an equivalent number or amount of debits). In a system which allows for the acquisition of intermediated securities without corresponding debits, however, the innocent acquisition principle has more the character of a limitation of the acquisition, which is generally possible by the person to whose securities account the credit was made. In such a system, the protection of an innocent acquirer may create a shortfall or imbalance in securities that States might decide to resolve by requiring regular or periodic reconciliation by issuers or intermediaries (including CSDs) or by using the intermediary's securities, if any, to correct the shortfall. See paragraph 217 below.

177. Second, in a Contracting State that regards the transfer (of rights) as a contract that is separate and abstract from the underlying contract, the transfer of intermediated securities is not directly affected by the invalidity (rescission) of the underlying contract (principle of abstraction). Hence, the transfer is, in principle, valid, even though the acquired right or interest has to be returned on the ground of unjust enrichment. The situation is, of course, different if the transfer itself is void. But in this case the acquirer will already be protected under Article 18(1). Consequently, resort to Article 18(2) may not be necessary in such a State.

178. Lawmakers should be aware that the rights and liabilities of acquirers in case they are not protected by Article 18(1) or Article 18(2) are determined by the applicable law. Article 18(4) replicates the general principle that, if the Convention does not provide any special rules, the applicable law will determine the rights and liabilities of the respective persons.

2. Choices to be made by declaration

179. The Convention neither requires nor permits declarations in respect of the matters discussed in this section.

3. Matters to be addressed or clarified

180. The law should clarify whether and to what extent the rules of a SSS or an account agreement may limit the innocent acquisition principle of Article 18(2). If so, the consequence is the reversal of (a series of) book-entries. The innocent acquisition principle under Article 18(1), however, is applicable at any rate. Because the Convention harmonises the “credit side” but not the “debit side” of transactions, the non-Convention law may require that, in the case of acquisition by an innocent person, a corresponding debit must occur in order to avoid an “inflation” of securities. See paragraph 176.

181. Lawmakers may also consider whether to extend the scope of the protection offered to innocent acquirers under Article 18 and determine other circumstances in which an innocent acquisition of intermediated securities will be protected. Indeed, law outside the Convention may provide more generous protection than that provided by Articles 18(1) and 18(2).

D. Priorities

Legislative Principle #7: The Convention provides clear priority rules that apply among competing claimants to the same intermediated securities. The law may supplement and adjust these priority rules. The law should address priority contests that are not resolved by the Convention.

1. Core Convention principles and rules

182. The core principles and rules are the following:

- The Convention sets out basic priority rules for interests made effective under Articles 12 and 13 with respect to the same intermediated securities (i.e. securities credited to the same securities account). Article 19.
- The Convention partially determines the priority among an intermediary’s collateral taker and its account holder. Article 20.
- The Convention contains a general transition rule, which preserves the priority of interests created under the non-Convention law of a Contracting State before the Convention has entered into effect in relation to the Contracting State. Article 39.

183. Subject to exceptions mentioned below, interests made effective under Article 12 have priority over interests otherwise effective under the non-Convention law (i.e. Article 13 interests). Article 19(2).

184. Exceptions to the Article 19(2) priority rule are made for non-consensual security interests, as to which the Convention defers to priority rules under the non-Convention law under Article 19(5), and for the priority of interests created by an intermediary as against the rights and interests of the intermediary’s account holders governed by Article 20.

185. Article 19(3) provides the baseline temporal priority rule. Interests made effective under Article 12 rank according to the time (a) of an intermediary’s acquisition of an interest under Article 12(3)(a); (b) of the making of a designating entry; and (c) that a control agreement is entered into or, if applicable, that the relevant intermediary receives notice that a control agreement has been entered into.

186. Article 19(4) provides a special non-temporal priority rule. If an intermediary holds an effective Article 12 interest and subsequently makes a designating entry or enters into a control agreement in favour of another person, the other person's interest has priority unless the parties expressly agree otherwise.

187. Article 19(6) permits parties to vary the otherwise applicable priorities by agreement, except that applicable law governs whether parties may vary the priority of a non-consensual security interest. See paragraphs 192-195 below.

188. Under Article 20, an interest granted by an intermediary under Article 12 has priority over the rights of the intermediary's account holders unless the intermediary's grantee knew or ought to have known that the interest violated the rights of one or more account holders. Article 20(2). This is essentially the same test of innocence provided in Article 18(1). The Convention leaves to non-Convention law the relative priorities in the case of the grant of an interest by the intermediary under Article 13. See paragraphs 196-197 below.

2. Choices to be made by declaration

a. Declaration regarding priority of interests granted by designating entry

189. A Contracting State may declare that an interest made effective by a designating entry has priority over interests granted by other methods, subject to the priority rule in Article 19(4). See paragraph 186 above. For more information on the optional declaration under Article 19(7), see the Declarations Memorandum, Section 4.E and accompanying Form No. 5.

b. Declaration regarding transitional provision

190. Under the transition rule variation in Article 39(2), a Contracting State may declare that a pre-existing interest will retain its priority under Article 39(1) only if it is made effective under Article 12 before the relevant date.

191. Pre-existing interests are defined in Article 39(3)(a) to mean consensual interests granted under the non-Convention law other than by a credit to a securities account. The relevant date is defined in Article 39(3)(b) to mean the date stated by the Contracting State in its declaration, but not later than two years after the declaration's effective date. For more information on the optional declaration under Article 39(2), see the Declarations Memorandum, Section 4.J and accompanying Form No. 10.

3. Matters to be addressed or clarified

a. Non-consensual security interests

192. Because Article 19(5) leaves the priority of non-consensual security interests to the applicable law, a Contracting State should reconsider any such applicable priority rules for consistency with and conformity to the policies embodied in the Convention.

193. In particular, a Contracting State should consider whether the priority of any or all applicable non-consensual security interests may be varied by agreement. See Article 19(5)-(6).

194. If the non-Convention law of a Contracting State provides, or if a Contracting State is giving consideration to the enactment of a law which provides, that an intermediary acting as an agent or broker obtains a non-consensual security interest in securities to secure an account holder's obligation to pay for the securities, then the Contracting State should consider the priority given (or to be given) to that security interest. The Contracting State should consider giving first priority to such a non-consensual security interest, subject to the operation of Article 19(4).

195. A Contracting State should consider whether a right of retention or similar right or interest provided under the State's civil code, commercial code, or both applies to intermediated securities for the benefit of the relevant intermediary. The State should consider clarifying such provisions with respect to the

applicability or non-applicability to intermediated securities and, if applicable, the priority of such a right or interest.

b. Priorities regarding interests granted by non-Convention methods

196. If and to the extent that the priority rules applicable to interests created under the non-Convention law of a Contracting State differ from those applicable under the Convention, the Contracting State should consider conforming those rules to the Convention's rules.

197. In particular, a Contracting State should consider conforming the priority rule for an interest granted by an intermediary under the non-Convention law (i.e. an Article 13 interest) to be consistent with Article 20(2).

c. Priorities of interests granted by an intermediary

198. Except for the protection of an innocent acquirer contained in Article 20(2), the Convention does not determine the result of a priority contest between the interests of account holders and an effective interest granted by the intermediary under Articles 12 or 13. Such a priority contest may occur, for example, in the case of an insolvent intermediary and the occurrence of a shortfall in securities. As such a contest is to be determined by the applicable law, a Contracting State may wish to consider its law in this regard and, in particular, how that contest should be resolved. See Article 20(1) and OFFICIAL COMMENTARY, paragraphs 20-7 to 20-10.

V. INTEGRITY OF THE INTERMEDIATED HOLDING SYSTEM

A. Prohibition of upper-tier attachment

Legislative Principle #8: The Convention, with limited exceptions, prohibits any attachment of intermediated securities of an account holder against, or so as to affect (a) a securities account of any person other than that account holder, (b) the issuer of any securities credited to a securities account of that account holder, or (c) a person other than the account holder and the relevant intermediary.

1. Core Convention principles and rules

199. The core principles and rules are the following:

- The Convention generally prohibits upper-tier attachment, subject to an exception specified under Article 22(3). See Article 22(1).
- The phrase "upper-tier attachment" is commonly used where a creditor of an account holder attempts to attach securities credited to a securities account maintained by an intermediary which is not the account holder's/debtor's relevant intermediary.
- In other words, upper-tier attachment indicates that the creditor tries to attach at an inappropriate tier of the holding chain.

200. The prohibition of upper-tier attachment is based on an important policy consideration. Permitting such attachment would undermine the ability of an intermediary to perform its functions and disrupt the integrity of the intermediated securities holding system. What should be avoided is that such an attachment order blocks securities accounts of other account holders who have nothing to do with the subject matter of the attachment. If upper-tier attachment is permitted, such blockage could happen because upper-tier intermediaries usually do not know and are unable to specify what part of the securities or intermediated securities are the relevant securities that should be subject to the attachment. Even if upper-tier intermediaries can identify the relevant securities or intermediated securities, permitting upper-tier attachment could produce enormous costs for the relevant upper-tier intermediary in identifying the

relevant securities or intermediated securities and could prevent efficient operations of the intermediated securities holding system. Upper-tier intermediaries will, in general, be unable to determine if the relevant securities or intermediated securities may be subject to a security interest or attachment order at the level of the relevant intermediary. The prohibition of upper-tier attachment thus ensures that the rights of the holders of such a security interest or attachment will not be adversely affected, and the provided exception to that prohibition is meant for transparent systems and to be used with caution. See paragraph 203.

201. This policy is particularly important in the cross-border context, inasmuch as if some systems permit upper-tier attachment and others do not, it would seriously harm compatibility and thus efficiency of cross-border holding of intermediated securities.

202. The definition of attachment is broad. Article 22(2) defines “attachment of intermediated securities of an account holder” as “any judicial, administrative or other act or process to freeze, restrict or impound intermediated securities of that account holder in order to enforce or satisfy a judgment, award or other judicial, arbitral, administrative or other decision or in order to ensure the availability of such intermediated securities to enforce or satisfy any future judgment, award or decision.”

2. Choices to be made by declaration

203. As an exception to the general prohibition of upper-tier attachment, Article 22(3) allows a situation in which an attachment is permitted to be made against a person other than the relevant intermediary. This is often the case in the context of holding patterns (the so-called “transparent systems”) where the relevant intermediary shares its functions with a third person. See Article 7 and paragraphs 51 and 103 et seq. above. However, the exception of Article 22(3) can also apply where there is no holding pattern built on such shared functions in the sense of Article 7.

204. In particular, a Contracting State would have to declare that, under its non-Convention law, an attachment of intermediated securities of an account holder made against or so as to affect a person other than the relevant intermediary has effect also against the relevant intermediary. Any such declaration would also have to identify that other person by name or description and shall specify the time at which such an attachment becomes effective against the relevant intermediary.

205. The rationale for this exception lies in the general purpose of the prohibition of upper-tier attachment (i.e. upper-tier attachment risks disrupting the holding chain). However, this detrimental effect can be avoided where the applicable law provides for special safeguards avoiding such disruption, in particular reconciliation mechanisms which allow the relevant intermediary and the other person to communicate with each other and have procedures in place which guarantee that an attachment made at the level of one entity is correctly reflected in the accounts maintained by the other entity.

206. In many (probably most) cases, a Contracting State making a declaration under Article 22(3) will also have made a declaration under Article 7(1) with respect to the sharing of intermediary functions. However, Article 22(3) does not limit its applicability to such Contracting States as it is based on the assumption that a Contracting State that elects to make a declaration under Article 22(3) will do so rationally and only if a system is in place (through the use of information technology or otherwise) which ensures that the problems and risks that Article 22(1) is intended to prevent are adequately addressed.

207. Where a declaration under Article 22(3) is made, it must identify the other person by name or description. Furthermore, it must specify the time at which such an attachment becomes effective against the relevant intermediary. The latter requirement shows that the decisive account at which to look remains under all circumstances the one held for the debtor by the relevant intermediary. Only if and when the attachment of intermediated securities standing to the credit of that account takes legal effect, the intermediated securities are validly frozen, restricted or impounded. Until that point, the intermediated securities can be disposed of. For more information on the optional declarations under Articles 7 and 22(3), see the Declarations Memorandum, Section 4.C and accompanying Forms 3.A and 3.B (regarding Article 7) and Section 4.F and accompanying Form No. 6 (regarding Article 22(3)).

3. Matters to be addressed or clarified

208. To make a declaration under Article 22(3), a Contracting state should make sure that, under its non-Convention law, an attachment of intermediated securities of an account holder made against or so as to affect a person other than the relevant intermediary has effect also against the relevant intermediary. If the relevant intermediary is a foreign entity, however, attachment made against or affecting a person other than the relevant intermediary should be permitted only if it has effect against the relevant intermediary under the applicable law or as a result of consent or contract.

B. Prevention of shortfalls and allocation of securities

Legislative Principle #9: The Convention requires intermediaries to prevent shortfalls, notably by holding or having available sufficient securities to cover credits to securities accounts that these intermediaries maintain. The law should regulate the method, manner, and time frame for compliance.

The Convention also requires intermediaries to allocate securities to account holders' rights. The law may establish a specific form of segregation as a method of allocation.

1. Core Convention principles and rules

209. The core principles and rules are the following:

- An intermediary should hold or have available sufficient securities to cover credits made to securities accounts it maintains. Article 24.
- An intermediary should allocate securities to account holders' rights. A common way to do this is segregation. Article 25.

210. It is crucial for the integrity of an intermediated securities holding system to prevent shortfalls as much as possible, to provide for correction mechanisms when they occur, and to have rules in place for the distribution of losses due to shortfalls in insolvency. The Convention addresses these issues in Articles 24-26. Lawmakers should ensure that intermediaries hold or have available sufficient securities (Article 24) and that securities are allocated to account holders, notably by way of segregation (Article 25). The Convention rule regarding the distribution of losses in insolvency (Article 26) and alternative solutions are dealt with in paragraphs 263-264 and 267 below.

a. Sufficient securities

211. Lawmakers should ensure that an intermediary holds or has available sufficient securities to cover credits to securities accounts it maintains or, in technical and more precise terms, "hold[s] or [has] available securities and intermediated securities of an aggregate number or amount equal to the aggregate number or amount of securities of that description credited to: (a) securities accounts that it maintains for its account holders other than itself; and (b) if applicable, securities accounts that it maintains for itself". Article 24(1).

b. Allocation

212. In addition to ensuring that intermediaries hold or have available sufficient securities and intermediated securities (Article 24), lawmakers should also make sure that these securities are allocated to the rights of the account holders of the intermediary concerned (Article 25). This allocation is an important tool in determining which assets belong to whom. The allocation should take place to account holders other than the intermediary itself. The default policy set out in the Convention is that securities are deemed to be allocated to such account holders up to the aggregate number or amount of their credits, and that these securities are *not* available to the intermediary's other creditors in case of its insolvency. States may, however, deviate from this policy by making a declaration.

213. The Convention does not determine exactly how allocation takes place, which is thus left to domestic lawmakers. Article 25(3). However, the Convention does mention the commonly applied method of segregation. Article 25(4). Two different types of segregation can be distinguished in the context of holding through upper-tier securities accounts. In the first case of pooled “omnibus accounts”, the securities of a certain description that an intermediary holds for itself are distinguished from those of all its account holders, whose securities of that description are pooled in an omnibus account. In the second case of so-called “individual segregation”, a distinction is made between an intermediary’s own securities and those of particular account holders or groups of account holders individually. It should be noted that these different methods of segregation can also be combined: an intermediary may hold securities of a certain description for (a) itself, (b) one or more account holders individually, and (c) remaining account holders in an omnibus account.

Diagram 213-1: Omnibus account

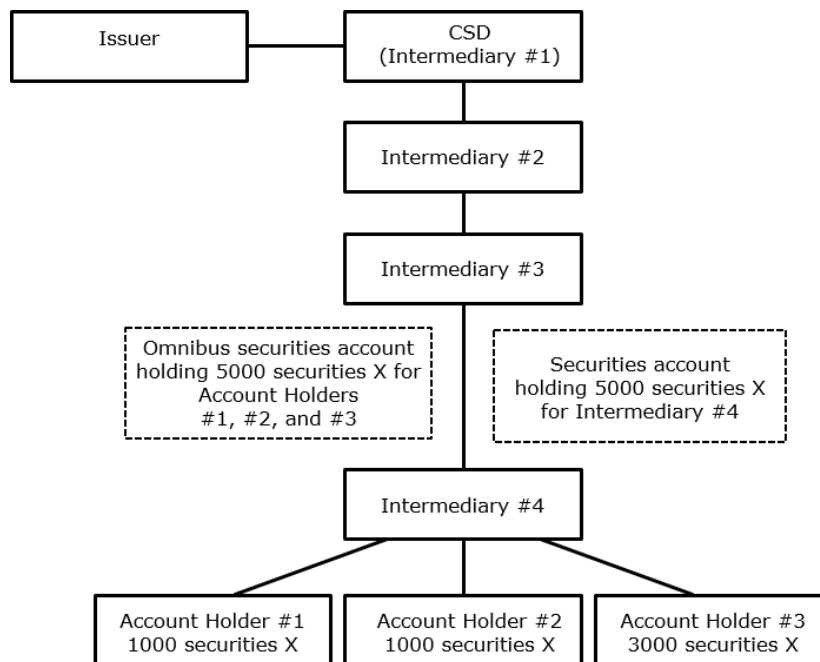

In diagram 213-1, intermediary #4 holds 10000 securities X in two accounts with intermediary #3. An omnibus account contains 5000 securities X held for account holders #1, #2, and #3; another account contains 5000 securities X that intermediary #4 intends to hold for itself. Intermediary #3 only knows intermediary #4, not the identity of account holders #1, #2, and #3.

Diagram 213-2: Individual segregation

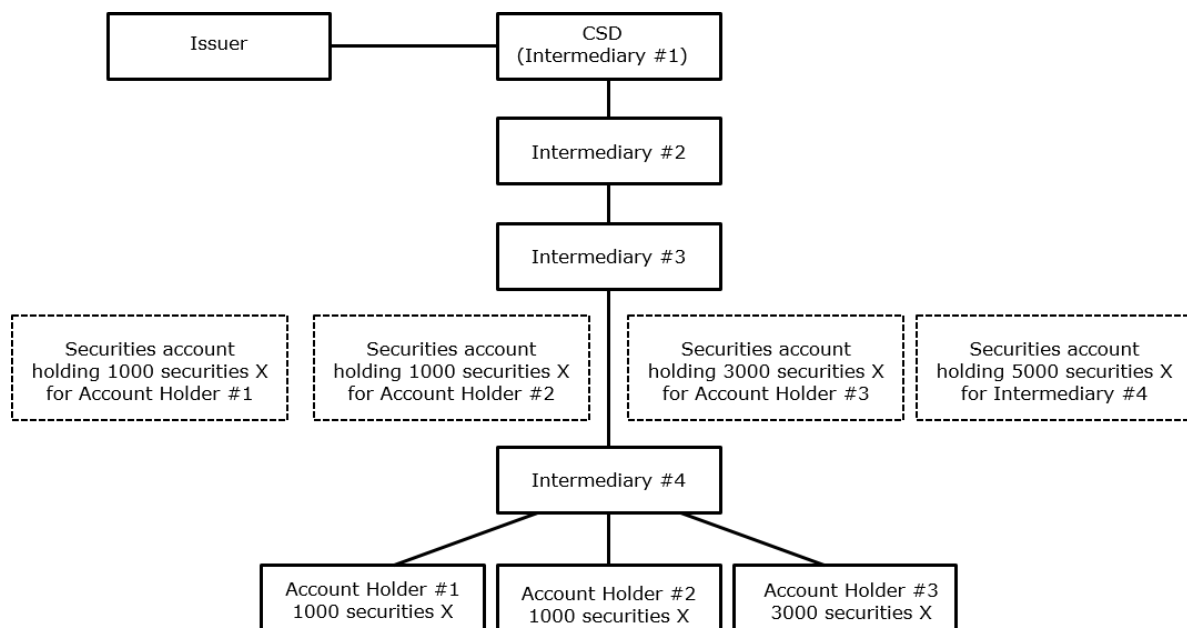

In diagram 213-2, intermediary #4 holds accounts with intermediary #3 for each of its account holders individually, as well as for securities it holds for itself. Intermediary #3 knows the identity of intermediary #4 and of its account holders. In order for the individual segregation to be effective throughout the chain, it must also be ensured at upper-tiers (intermediary #2, etc.).

2. Choices to be made by declaration

a. Sufficient securities

214. The Convention neither requires nor permits declarations in respect of the requirement to hold or have available sufficient securities.

b. Allocation

215. The default rule of the Convention is that securities that are available under Article 24 are *ex Conventione* allocated to account holders and are not available to the intermediary's other creditors in its insolvency. However, a State may decide to protect the intermediary's other creditors instead of the intermediary's account holders by giving "proprietary effect" to the segregation by an intermediary of securities that it holds for its own account. If the non-Convention law of a State so provides and if a declaration is made to this end, only the securities allocated to the intermediary's account holders will be available to these account holders, whereas all other "own account" securities are available to the intermediary's other creditors. For more information on the optional declaration under Article 25(5), see the Declarations Memorandum, Section 4.G and accompanying Form No. 7 and OFFICIAL COMMENTARY, paragraph 25-20 and ex. 25-6.

3. Matters to be addressed or clarified

a. Sufficient securities: Available methods, time frame for action, and allocation of costs and other consequences

216. Lawmakers should decide on the different methods that are made available for complying with the requirement to hold or have available sufficient securities. Different methods are listed in Article 24(2) and include registration in the issuer's register (either in the name or for the account of account holders or in the intermediary's own name), possession of certificates or other documents of title, holding intermediated securities with another intermediary, or any other appropriate method. The suitability of these methods depends on the set-up of a given intermediated system.

217. Lawmakers should also consider the time frame within which corrective action should be undertaken in case the requirement to hold or have available sufficient securities is not complied with at any given moment. Article 24(3). Such corrective action – to make up the difference – could include an intermediary purchasing securities or intermediated securities from the market or from one or more of its account holders, or using a securities lending arrangement to borrow securities or intermediated securities from the market or from its account holders. Again, the policy decision on the time frame to be provided depends on the set-up of a given system. Some systems envisage an inseparable link between credits and debits (the so-called “no credit without debit” rule) and any mismatch within the system is therefore conceptually impossible. Other systems envisage some leeway as long as there is a form of financial backup to protect account holders.

218. Another matter that is left to domestic lawmakers is the allocation of cost and any other consequences of non-compliance with the requirement to hold or have available sufficient securities. Article 24(4).

b. Allocation/segregation

219. Lawmakers should decide on the available methods of allocation, including by way of segregation. See paragraphs 212-213 above.

C. Securities clearing and settlement systems

Legislative Principle #10: The Convention recognises the systemic importance of securities clearing or settlement systems, and in some instances allows derogations to the rules of the Convention to the extent permitted by the law applicable to the system. The law should only allow for derogations to the Convention rules where such derogations are necessary to ensure the integrity of the local securities clearing or settlement systems.

The law should clearly determine when an instruction or a transaction within a securities clearing or settlement system becomes irrevocable and final, notwithstanding the insolvency of the operator of the system or one of its participants.

1. Core Convention principles and rules

220. The core principles and rules are the following:

- The Convention contains definitions of an SCS and an SSS. See Articles 1(n) and 1(o) and, for discussion, see paragraph 70 above and the Glossary.
- Only SCSs or SSSs that (a) are central to the reduction of risk to the stability of the financial system (i.e. systemically important institutions) and (b) have been identified as an SCS or SSS in a declaration of the Contracting State qualify as such under the Convention.

221. The effective and safe operation of systemically important systems requires their internal rules and procedures to be enforceable with a high degree of certainty and tailored to their particular legal context. This is why Articles 9(1)(c), 10(2)(c), (e), (f), 15(1), 16, 18(5), 23(2)(e), 24(4), 26(3), 27(a)-(b), 28(1)-28(2) and 28(3) of the Convention provide that the uniform rules of an SSS may contain rules which either derogate from the Convention or the ordinary laws of the Contracting State. Lawmakers should thus give serious consideration to the establishment of SCSs and SSSs as an integral part of the infrastructure for the operation of an intermediated securities holding system.

222. SSSs which meet the above criteria can benefit from the Convention’s exemptions. Although the SSS in its dealings with the issuer is in some systems identified as a CSD, the reality is that the SSS is a completely different financial market infrastructure with a different function from the CSD. Except in systems where the SSS is also a CSD, both financial market infrastructures work closely to maintain the efficiency and integrity of the intermediated securities holding system. To the extent that those dealings

include the creation, recording and reconciliation of securities vis-à-vis the issuer, pursuant to Article 6, they are excluded from the scope of the Convention.

223. Article 27, in addition, recognises the effects of law applying to SCSs or SSSs which provide for the irrevocability of instructions and the finality of recordings in an insolvency scenario of a participant to any such system or of the system itself. Such irrevocability and finality is important because settlement of securities within an SSS or SCS are particularly vulnerable to being unwound in an insolvency scenario. There is often a delay between entering instructions and the finalisation of the clearing and settlement process, and the revocation of instructions once they have been entered could create huge practical problems by causing the unwinding of already netted obligations or settlement positions, with potential systemic consequences. In order to avoid such consequences, it needs to be ensured that transfer orders entered into a system can be settled and that book-entries would remain effective regardless of whether a participant or the system operator becomes insolvent. See OFFICIAL COMMENTARY, paragraph 27-20 et seq.

2. Choices to be made by declaration

224. To ensure predictability for intermediaries, it is important that they can easily identify whether an entity or system can derogate, either pursuant to the law applicable to it or by virtue of its uniform rules, from the rules of the Convention. To that effect, the Convention permits each Contracting State to identify in a declaration the SCSs or SSSs which are to be subject to it, because the effect is to extend the recognition afforded by the Convention to uniform rules of a SCS or SSS to those systems specifically identified.

225. Only the Contracting State, whose laws govern a system, may make a declaration, not the Contracting State whose laws govern the agreement between the SCS or SSS and their participants (if different).

226. Only SCSs and SSSs that are central to the reduction of risk to the stability of the financial system may be identified. This means that only systemically important institutions may be listed in a declaration. For more information on the optional declarations under Articles 1(n)(iii) and 1(o)(iii), see the Declarations Memorandum, Section 4.A and accompanying Form No. 1 and OFFICIAL COMMENTARY, paragraph 1-106.

3. Matters to be addressed or clarified

227. Lawmakers should, with respect to each instance mentioned in paragraph 221, carefully consider which derogations to the Convention or to their domestic law they shall allow for the operation of SCSs and SSSs. Bearing in mind the complexities associated with SCSs and SSSs, lawmakers are referred to the references to the OFFICIAL COMMENTARY contained in Annex 5 on the uniform rules of SCSs and SSSs and to the specialised guidance provided by, among others, BIS and IOSCO, including the Principles for Financial Market Infrastructures.

228. In considering such guidance, Contracting States should only allow derogations to the Convention rules if such derogations are essential to ensure the integrity of the SCS or SSS in light of their systemic importance.

229. Further to paragraph 223 above, Contracting States are encouraged to introduce rules on irrevocability of instructions and finality of recordings with respect to transactions settled through an SCS or SSS, and in particular in the case of an insolvency proceeding of a participant of the SCS or SSS, or of the SCS or SSS itself, in order to ensure the integrity of both the national and international financial systems.

D. Issuers

Legislative Principle #11: The Convention generally does not deal with the relationships between account holders and issuers. The law should clearly define the persons entitled to exercise the rights attached to the securities vis-à-vis the issuer and the conditions for such exercise. The law should facilitate the exercise of those rights by the ultimate account holder, in particular, by allowing intermediaries who act on behalf of account holders to exercise voting rights or other rights in different ways, and should recognise holding through nominees.

In the insolvency proceeding of an issuer, the Convention provides that an account holder is not precluded from exercising a right of set-off merely because it holds securities through intermediaries.

1. Core Convention principles and rules

230. The core principles and rules are the following:

- The Convention generally does not deal with the relationships between account holders and issuers. Article 8.
- However, the Convention contains a few exceptions to that principle that are considered necessary to achieve compatibility of intermediated securities holding systems around the world. Articles 29 and 30.
- Contracting States should permit the holding of publicly traded securities through one or more intermediaries, and the effective exercise of the rights attached to such securities that are so held; in particular, they shall recognise the holding of such securities by a person acting in its own name but on behalf of another person or other persons and shall permit such a person to exercise voting or other rights in different ways. Article 29.
- Contracting States should not discriminate between non-intermediated and intermediated securities with regard to set-off rights in relation to the insolvency of the issuer. Article 30.

231. As discussed in paragraph 24 above, securities give investors certain rights that the Convention refers to as "the rights attached to the securities". See, e.g., Articles 8(2), 9(1)(a)).

232. In intermediated holding systems, investors may be unable to exercise directly those rights against the issuer, because the person who appears in the issuer's register or in the CSD (when this institution replaces that register) may not be the ultimate account holder. Issuers may not know who the investors are and, accordingly, investors may not be entitled to exercise the rights attached to the securities directly against the issuers.

233. In this context, the Convention takes as a starting point the difference between the exercise of the rights attached to the securities (a) vis-à-vis the relevant intermediary and (b) vis-à-vis the issuer. The Convention focuses on the relationship between the account holder and its intermediary and establishes that the rights attached to the securities belong to the account holder and that the intermediary must ensure the exercise of those rights. See Articles 9-10 and Part III.A-B above.

234. However, the Convention, in principle, does not deal with the relationship between account holders and issuers. Article 8 enshrines this principle. On the one hand, from the account holder's standpoint, the Convention does not affect any right of the account holder against the issuer of the securities. Article 8(1). On the other hand, from the issuer's standpoint, the Convention does not determine whom the issuer is required to recognise as the shareholder, bondholder or other person entitled to receive and exercise the rights attached to the securities. Article 8(2).

235. The Convention is therefore neutral as to whether the rights attached to the securities are to be exercised by the ultimate account holder, its intermediary or any other upper-tier intermediary. This is a matter governed by the law applicable to the securities. This law also governs the conditions to exercise

those rights. For example, the law governing the issuer may establish that, when the shareholders exercise their voting rights by proxy, a valid proxy card must be prepared, signed and submitted to the issuer within a certain number of days before the shareholders meeting. These rules are not affected by the Convention.

236. This law will usually be the law of the issuer with regard to shareholders and the law governing the bonds with regard to bondholders (together, sometimes referred to here as the law governing the securities). This law can be the law of a Contracting or non-Contracting state. That is why on this point Article 9(1)(c) refers, among others, to the applicable law and the terms of the securities.

237. As shown in diagram 237-1 below, for example, an account holder has a securities account with an intermediary. The account is located in State B, but the securities credited to that account are issued under the law of State A. The Convention does not say anything about whether the ultimate account holder, his intermediary (#3) or any other intermediary at an upper-tier (intermediary #2 or the CSD (intermediary #1)) is entitled vis-à-vis the issuer to exercise the rights attached to those securities. The law of State A may, for example, only recognise as shareholder the persons whose names appear in the issuer's register at a certain date. Unless and until the name of the account holder appears on such register, the issuer is not obliged to treat that ultimate account holder as shareholder. This means the account holder's right over the securities are effective against the intermediary and third parties (see Article 9), but the account holder will not be entitled to exercise those rights against the issuer.

Diagram 237-1: Application of State A's law to relationships between the Issuer and CSD (Intermediary #1) and the CSD and Intermediary #2

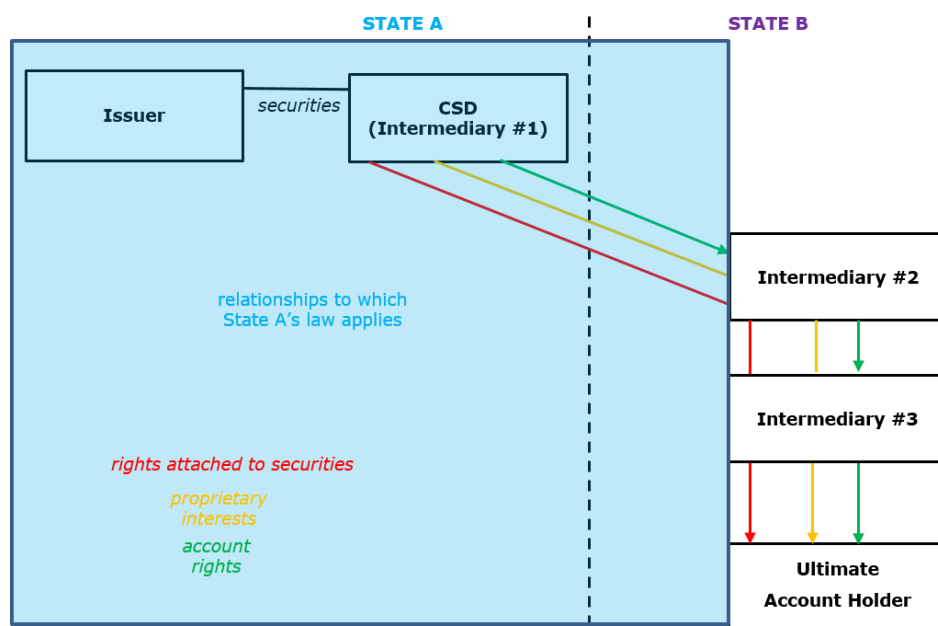

238. Even if under the law governing the securities, however, the account holder is not entitled to exercise the rights attached to such securities against the issuer, Article 10 establishes that intermediaries must take appropriate measures to enable their account holders to receive and exercise those rights. As an example of such measures, intermediaries should exercise voting rights following their instructions or should appoint them as proxy holders to attend and vote at the general meeting.

239. Articles 29 and 30 include exceptions to the principle laid down by Article 8. Though the Convention does not generally apply to the relationships between issuers and account holders, Articles 29 and 30 contain certain exceptions to this principle that were considered necessary to achieve compatibility of intermediated securities holding systems around the world.

240. Article 29(1) establishes an element that is crucial for the well-functioning of exchanges or regulated markets, in particular to ensure cross-border compatibility of the various models of holding systems: the recognition of intermediated holding systems. Contracting States shall permit publicly traded securities (i.e.

the securities traded on exchanges or regulated markets of the corresponding Contracting State) to be held through one or more intermediaries and recognise the effective exercise of the rights attached to those securities, and such recognition works with all the models, as well as mixed and transparent systems, described in Part I.B above. Contracting States, however, are not obliged to require that all securities are issued on terms that allow them to be held through intermediaries. See Article 29(1) *in fine*.

241. Furthermore, Article 29(2) adds that Contracting States shall recognise the holding of securities by a person acting in its own name but on behalf of another, and to permit that person to exercise voting rights or other rights in different ways. In particular in cross-border scenarios, it is common that intermediaries act in their own name (as nominees) but also on behalf of third parties (beneficiaries). The purpose of this provision is to ensure recognition of this nominee holding fact-pattern to ensure the interoperability of different systems.

242. The Convention, however, does not prevent the non-Convention law from establishing certain conditions for a person (the nominee) to be able to exercise those rights. For instance, the law governing the issue (that of State A in diagram 237-1) may require the nominee to disclose the name of its clients in order to vote in different ways.

243. Article 30 provides an equal footing rule between intermediated and non-intermediated securities with regard to set-off but only in relation to the insolvency of the issuer. If a set-off right would have existed and would have been exercisable in a non-intermediated context (e.g. when the investors hold a certificate of bonds), such rights must also exist and be recognised where the securities are held through one or more intermediaries. The reach of this provision is very limited, as it only prevents Contracting States from discriminating *on the mere fact* of the intermediation. Whether set-off rights exist and are enforceable in the insolvency of the issuer is outside the scope of the Convention.

2. Choices to be made by declaration

244. The Convention neither requires nor permits declarations in respect of the matters discussed in this section.

3. Matters to be addressed or clarified

245. The non-Convention law must define the persons entitled to exercise the rights attached to the securities vis-à-vis the issuer and the conditions thereto when the securities are held through one or more intermediaries. From a conflict of laws perspective, the Contracting State should make it clear that these provisions only apply to the securities governed by its own law. See generally Part VIII below.

246. The conditions for the exercise of those rights vis-à-vis the issuer should be clearly stated so that they provide legal certainty and predictability to: (a) the issuer, in particular regarding whom it is required to recognise as entitled to exercise those rights; (b) and the intermediaries and account holders, in particular regarding who is entitled to exercise them against the issuer. This includes the determination of the date relevant for the identification of the person entitled to a specific corporate action.

247. Furthermore, the non-Convention law should facilitate the exercise of the rights attached to the securities by the ultimate account holders, in particular establishing a transparent, smooth and effective process of proxy voting. Thus, if the person entitled to exercise the corporate rights vis-à-vis the issuer is acting as a nominee, the law should clearly establish under what conditions such person may exercise the rights stemming from the securities on behalf of clients.

248. The law should also clearly establish that nominees will not be prevented from granting a proxy to each of their clients or to any third party designated by a client.

249. As a corollary of the recognition of intermediated securities holding systems, the non-Convention law should ensure a general principle of non-discrimination with regard to the exercise of the rights attached

to the securities wider than the simple exercise of voting rights. The law governing the securities should not discriminate against the exercise of the rights attached to the securities *on the sole grounds* that the securities are held through a chain of intermediaries. And this principle should apply not only to nominee systems but also to alternative systems of holding securities indirectly (e.g. by means of omnibus accounts).

VI. INSOLVENCY PROTECTION

Legislative Principle #12: The Convention establishes important insolvency proceeding-related rules on the interests made effective against third-parties and provides loss-sharing rules in case of a shortfall of account holder securities. However, the law should address many other important and relevant features of insolvency and regulatory law that the Convention leaves to it.

A. Core Convention principles and rules

250. The core principles and rules are the following:

- The Convention deals generally with the effectiveness of interests made effective under Articles 11, 12, or 13 as against an insolvency administrator and creditors in an insolvency proceeding. Article 14.
- The Convention partially determines the priority among an intermediary's collateral taker and its account holders. Article 20 and see paragraph 188 above.
- The Convention deals generally with the effectiveness of interests made effective under Articles 11, 12, or 13 as against an insolvency administrator and creditors in an insolvency proceeding of the relevant intermediary. Article 21.
- The Convention provides a loss-sharing mechanism in case of a shortfall of securities credited to account holders' securities accounts in an insolvency proceeding of an intermediary. Article 26.
- The Convention shields the legal effects of certain provisions in the uniform rules applied in respect of the operation of SCSs and SSSs from adverse consequences flowing from the insolvency of the system operator or a system participant. Article 27.

1. Effectiveness in insolvency in general

251. Article 14(1) provides affirmatively that interests made effective under Articles 11 and 12 are effective in an insolvency proceeding.

252. Article 14(2) provides that Article 14(1) does not affect substantive or procedural rules applicable by virtue of an insolvency proceeding such as ranking of categories of claims, avoidance powers for preferences and fraudulent transfers, and the enforcement of rights to property under the control or supervision of an insolvency administrator.

253. Article 14(3) provides that Article 14(1) does not apply to the situation of an intermediary insolvency proceeding addressed by Article 21.

254. Under Article 14(4), the Convention does not impair the effectiveness in an insolvency proceeding of an interest that is effective under Article 13.

2. Effectiveness in the insolvency of the relevant intermediary

255. Article 21(1) provides affirmatively that interests made effective under Articles 11 and 12 are effective in an insolvency proceeding of the relevant intermediary.

256. Article 21(2) provides that Article 21(1) does not affect rules applicable in an insolvency proceeding of the relevant intermediary relating to avoidance powers for preferences and fraudulent transfers and procedural rules relating to the enforcement of rights to property under the control or supervision of the insolvency administrator. The exceptions in Article 21(2) are narrower than those provided by Article 14(2).

257. Article 21(3) provides that nothing in Article 21 impairs the effectiveness in an insolvency proceeding of an interest that is effective under Article 13.

3. Loss sharing in case of insolvency of the intermediary

258. Article 26 applies regarding loss sharing unless there is a conflicting rule applicable in the insolvency proceeding of the intermediary. Article 26(1).

259. If the securities of a description (i.e. a particular issue) allocated under Article 25 are insufficient to cover the securities of that description credited to securities accounts, the shortfall is to be borne (a) if the securities are allocated to a single account holder, by that account holder, and (b) otherwise by the account holders to whom the securities have been allocated in proportion to the number or amount of securities credited to securities accounts. Article 26(2). This is a *pro rata* allocation on an issue-by-issue basis.

260. If the intermediary is the operator of a SSS, the uniform rules of the SSS determine who bears the shortfall if the rules so provide.

B. Choices to be made by declaration

261. The Articles primarily addressed here do not involve choices to be made by declaration. However, the optional declaration under Article 25(5) regarding segregation is relevant in the context of an intermediary's insolvency proceeding. See paragraphs 212 and 215 above and 269 below.

C. Matters to be addressed or clarified

1. General observations

262. Many of the matters that must be addressed by the non-Convention law may fall within the realm of securities regulation—the regulation of securities markets and market participants such as intermediaries, exchanges and other trading systems, SCSs, and SSSs. Other matters are squarely in the field of insolvency law, but involve many complex and highly technical issues in the context of the insolvency of an intermediary. In this connection, many lessons have been learned through the recent financial crisis and in particular from the insolvency proceedings of various Lehman Brothers entities. There is a wealth of recent literature that should be consulted as well as much information available from the websites and publications of various NGOs. The most important available resources are listed on UNIDROIT's webpage for the Guide. A State wishing to reform its legal and regulatory infrastructure should consult these resources. While this section of the Guide endeavours to identify the most important areas of inquiry for such a reform process, it cannot provide detailed, specific recommendations.

2. Loss sharing

263. As Article 26 defers to a conflicting loss-sharing rule applicable in an intermediary insolvency proceeding, a Contracting State should consider whether it should retain or adopt any such different rule.

264. By way of example, assume that the intermediary has two account holders, #1 and #2. The intermediary has credited 100 units of A securities valued at 100 to account holder #1. It has credited 100

units of B securities valued at 100 to account holder #2. However, the intermediary only has 90 units available of A securities. Under the loss-sharing rule of Article 26(2), account holder #1 would bear the loss of the shortfall. Diagram 264-1 illustrates this result.

Diagram 264-1: Loss sharing under Article 26(2)

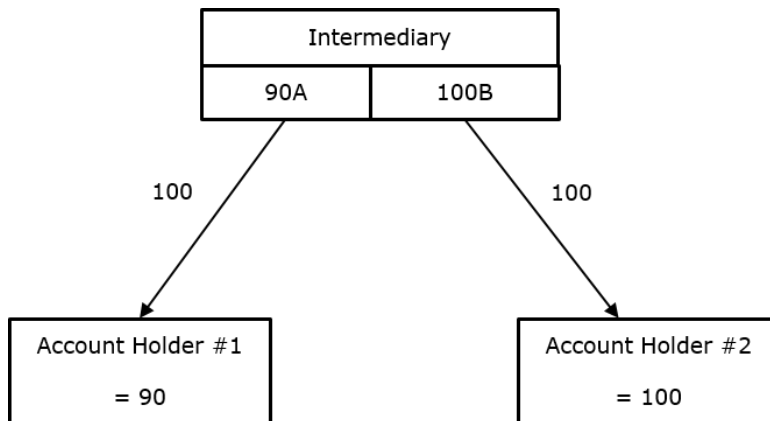

265. Under the loss-sharing rule in the security entitlement system of a North American common law State, all account holders share in the entire pool of securities to the extent of their net equity, which is the value of the securities credited to their accounts. This is so even if there is a shortfall. Diagram 265-1 illustrates this result. It reflects the fact that it normally would be purely fortuitous that there would be a shortfall in one issue of securities as opposed to another and would treat similarly situated account holders in the same manner.

Diagram 265-1: Loss sharing in the insolvency law for broker-dealers acting as intermediaries of a North American common law State

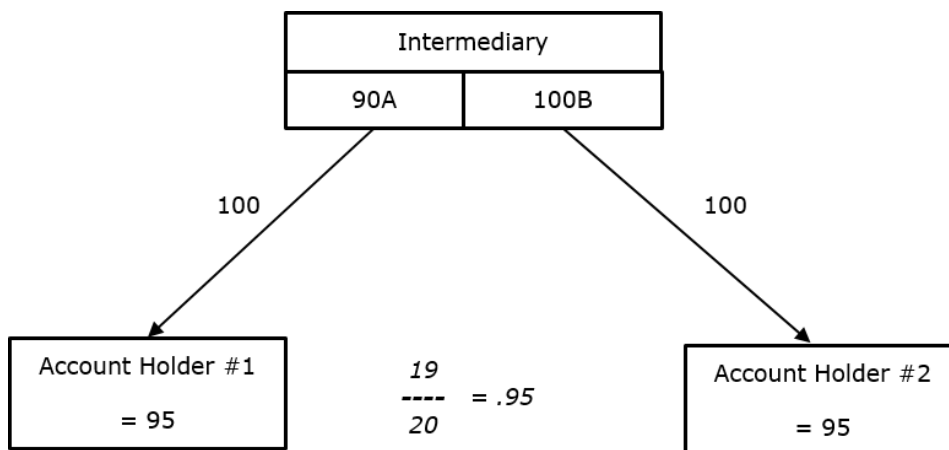

3. Priority of interests granted by intermediary

266. The priority of intermediary-granted interests as against the rights of the intermediary’s account holders is relevant primarily in the case of an intermediary insolvency proceeding. See generally paragraph 198 above.

4. Account holder protection fund or insurance

267. A Contracting State should consider adopting a scheme that provides a fund or insurance for the protection of “retail” account holders up to a specified value of securities carried in a securities account. If a Contracting State already has such a system, it should consider and assess its adequacy.

5. Transfer of account holder securities accounts to solvent intermediary

268. An important technique for the protection of account holders in the insolvency proceeding of an intermediary is the transfer of securities accounts (and the underlying securities) to a solvent intermediary that assumes the insolvent intermediary’s duties and obligations to the account holders. An account holder protection fund or insurance typically would provide assurances against losses to the transferee intermediary. A Contracting State should ensure that the relevant insolvency law accommodates this approach.

6. Rights of intermediary’s creditors and segregation

269. A Contracting State’s decision on whether or not to make a declaration under Article 25(5) regarding segregation and the corresponding impact on an intermediary’s account holders and unsecured creditors primarily is relevant in an intermediary’s insolvency proceeding. See generally paragraphs 212 and 215 above.

7. Limitations on ranking of categories of claims and avoidance powers

270. A Contracting State should consider whether to adjust ranking of claims and whether to adopt or retain protection from avoidance as a preference or fraudulent transfer of certain transfers as a mechanism to ensure that securities settlements are not invalidated merely because, for example, they take place mechanically during a relevant suspect period. Payments made to or within a SSS for the settlement of securities transactions, for instance, might be protected. In evaluating any such adjustments, Contracting States should take into account, in particular, the potential impact on systemic risk in financial markets.

8. Stay of enforcement and close-out netting

271. Related to the discussion in the preceding paragraph and the limitations discussed in Part VII below, and as a means of reducing systemic risk, in some States, enforcement against securities collateral and in connection with repo transactions and the operation of close-out netting is exempt from any stay or other injunction in an insolvency proceeding. See UNIDROIT Principles on the Operation of Close-Out Netting Provisions. A Contracting State should consider whether to adopt, retain, or adjust any such exemptions. See FSB, Key Attributes of Effective Resolution Regimes for Financial Institutions, paragraphs 4.1 et seq. and I-Annex 5 (October 2014, “FSB Key Attributes”) and, regarding a regulatory stay, paragraph 289 below.

9. Special provisions in relation to collateral transactions

272. If a Contracting State declares under Article 38 that Chapter V does not apply, it may nonetheless consider whether it should enact as a part of the non-Convention law the protection of collateral takers in connection with insolvency proceedings as under Articles 33, 36, and 37. See generally paragraph 277 et seq.

10. Return of account holder assets and funds

273. As to securities accounts that are not transferred to a solvent intermediary, a Contracting State should ensure that insolvency law provides means of promptly returning to account holders securities credited to their securities accounts and credit funds balances in such accounts. The law should provide for flexible solutions such as partial returns pending resolution of complex relationships and the potential for

an insolvency administrator to claw back securities and funds to the extent returns were not justified or were made in error. Ensuring that an account holder's rights are respected in an intermediary's insolvency proceeding, as under Articles 14(1) and 21(1), is a necessary but not a sufficient means of protecting the rights of account holders.

11. Intermediary access to SCSs and SSSs and assets held in such systems or otherwise as collateral

274. In order to provide proper protection and treatment of account holders and creditors generally, insolvency law should ensure that an insolvency administrator of an intermediary has access to information and records and access to assets held in such systems or otherwise held as collateral, such as by a clearing lender or derivatives counterparty. Of course, the interests of the operators of and participants in such systems and of those holding collateral must be protected as well. But it is important to ensure the transparency of all of these relationships. As to the insolvency of SCSs and SSSs, see Article 27 and paragraphs 227-229 above.

12. Intermediary access to information, records, and information technology systems

275. An intermediary's insolvency administrator must have access to all relevant information, records, and information technology systems to the extent available to the intermediary prior to an insolvency proceeding. A lack of access could be especially problematic in the case of a multinational financial corporate group in which an affiliate other than the intermediary manages information centrally and may be subject to a separate insolvency proceeding. Such access and other appropriate contingency plans for an intermediary's insolvency proceeding could be imposed or encouraged by the rules of an SSS. A Contracting State's supervisory or regulatory authority also should consider whether to impose or encourage relevant reporting or disclosure requirements.

13. Enhanced regulation and supervision of intermediaries, exchanges and alternative trading systems, SCSs, and SSSs

276. The optimal approach to the problem of intermediary financial distress would be to ensure that an intermediary does not suffer from financial distress in the first place. *Ex ante* regulation and supervision of intermediaries and the market structures and participants with which they interact may play an important role in this respect.

VII. SPECIAL PROVISIONS IN RELATION TO COLLATERAL TRANSACTIONS

Legislative Principle #13: The law should establish clear and sound rules in relation to collateral transactions involving intermediated securities. The Convention provides optional rules in relation to such transactions, whether by way of security collateral agreement or title transfer collateral agreement. Other international instruments and documents, reflecting lessons of the financial crisis, provide further guidance on regulatory, private and insolvency law issues involved.

A. Core Convention principles and rules

277. The core principles and rules are the following:

- The Convention covers collateral consisting of intermediated securities provided by way of a title transfer or a security collateral agreement. See Article 31.
- A title transfer collateral agreement should be able to take effect in accordance with its terms. Article 32.

- Enforcement of collateral may be effected by way of sale or, if agreed, appropriation or close-out netting. Article 33(1)-(2).
- It should be possible to enforce collateral relatively easily and quickly (i.e. without prior notice, approval by a court or other person, or a public auction), also in the case of insolvency. Articles 33(3) and 35. As a result of the financial crisis, enforcement is now subject to new, regulatory-inspired rules.
- The collateral taker may be given the right to “use” or “re-hypothecate” the collateral (i.e. to dispose thereof as if it were the owner). Article 34. As a result of the financial crisis, the right to “use” or “re-hypothecate” is now subject to new, regulatory-inspired rules.
- Collateral agreements and the provision of collateral thereunder are protected against timing claw back rules in insolvency (such as “zero hour rules”). Articles 36 and 37.

278. Chapter V of the Geneva Securities Convention contains optional, private and insolvency law oriented rules on transactions with collateral consisting of intermediated securities, including repurchase (or “repo”), securities lending, and collateralised derivatives transactions. See, e.g., paragraph 19 above and diagram 278-1 below. The choice to incorporate the rules of Chapter V in a given jurisdiction can be made independent of the choice to adopt the other rules of the Convention concerning basic features of the intermediated system. If opted into, the detailed character of the rules set out in Chapter V means that there are only a few instances for States to make declarations or determine the content of non-Convention law.

Diagram 278-1: Repurchase transaction

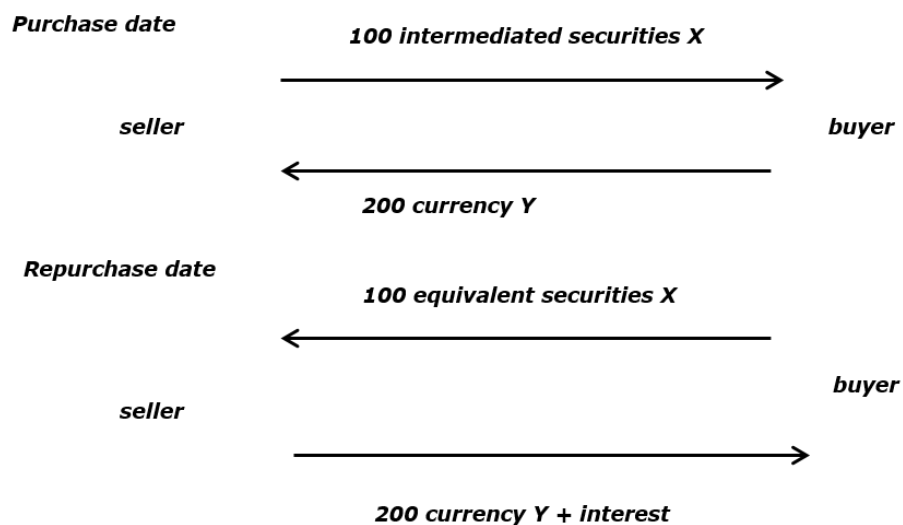

In a repo, a seller in need of cash transfers securities to a buyer outright in exchange for cash at the purchase date, while the seller returns the cash together with an interest component at the repurchase date in exchange for equivalent securities.

279. The global financial crisis of 2007 and onwards has triggered a range of regulatory standards in relation to securities financing transactions and other transactions involving financial collateral (in the regulatory-inspired debate on shadow banking the term “securities financing transactions” is common, which overlaps largely, but not entirely, with the transactions covered by Chapter V of the Geneva Securities Convention). Two key documents with international regulatory guidance, issued by the FSB, are: (a) Strengthening Oversight and Regulation of Shadow Banking: Policy Framework for Addressing Shadow Banking Risks in Securities Lending and Repos (August 2013, “FSB Shadow Banking Framework”) and (b) the FSB Key Attributes, to which reference is also made in paragraph 271 above.

280. The FSB Shadow Banking Framework (including also some follow-up FSB guidance documents) envisages enhanced transparency obligations regarding securities financing transactions, providing regulators with data to detect and address systemic risk; limits on cash collateral reinvestment; limits on the right of use or re-hypothecation; guidelines regarding collateral valuation and management; minimum regulatory haircuts for non-centrally cleared securities financing transactions; and standards for indemnification-related risks in the context of securities lending. The FSB Shadow Banking Framework also contemplates the possibility of a revision of insolvency law rules, as part of a broader debate among academics and regulators on the pros and cons of insolvency safe harbours. In addition, the FSB Key Attributes envisage a prohibition of the operation of “ipso facto clauses” (i.e. clauses that state that the mere fact that insolvency or resolution has commenced is sufficient reason to terminate the contract, either automatically or by one of the parties invoking termination) as well as a temporary “regulatory stay”, so as to enable resolution authorities to administer effectively financial institutions in distress.

281. The international regulatory standards are developed at the international level by the FSB and other bodies, such as the Basel Committee on Banking Supervision, and are subsequently translated into regional and domestic legislation and guidelines. Regional and domestic lawmakers may, and in practice do, provide rules and guidelines that specify and go beyond the standards proposed by the international bodies.

282. This new regulatory approach qualifies the liberal private and insolvency law oriented rules of Chapter V of the Convention. For example, the Convention’s rules that enable immediate enforcement in insolvency imply that ipso facto clauses are enforceable and that a temporary stay or moratorium is not allowed. This is opposed to the regulatory approach by which ipso facto clauses are not enforceable and by which resolution authorities should be provided with a window for decision-making in the form of a regulatory stay. See also paragraph 271 above. Lawmakers should take both the Convention’s rules and the new regulatory framework into account when considering rules on collateralised transactions.

B. Choices to be made by declaration

283. Various choices may be made by declaration. First, the personal scope of Chapter V may be limited. Second, intermediated securities that are not permitted to be traded on an exchange or a regulated market may be excluded. Third, categories of relevant obligations (i.e. the obligations of a collateral provider or another person for whom collateral is provided) may be excluded. Fourth, top-up or substitution arrangements may not receive protection if they are triggered by criteria relating to creditworthiness, financial performance, or the financial condition of the collateral provider.

284. Article 38 addresses the first three choices and provides lawmakers with possibilities to limit the scope of Chapter V. The first option is to limit the personal scope in order to protect natural persons or other categories of entities, notably entities that are not financial market participants, which are deemed to need protection. Article 38(2)(a). The second option is to apply the regime of Chapter V only to intermediated securities that are traded on an exchange or a regulated market (i.e. to securities that potentially have a significant impact on the liquidity of financial markets). Article 38(2)(b). The third issue that lawmakers should decide is whether there are relevant obligations that should not fall within the regime of Chapter V of the Convention. Article 38(2)(c). For more information on the optional declarations under Article 38, see the Declarations Memorandum, Section 4.I and accompanying Form No. 9 and OFFICIAL COMMENTARY, paragraphs 38-1 to 38-11.

285. Article 36 addresses the fourth choice and protects the provision of collateral in the course of a transaction under “top-up” and substitution arrangements against timing claw back rules. The declaration envisaged in Article 36(2) addresses the specific situation where top-up collateral should be provided as a consequence of changes to the creditworthiness, financial performance, or the financial condition of the collateral provider or another person owing the relevant obligations concerned. Such changes may be a prelude to the insolvency of the collateral provider. Lawmakers should decide on the policy question of whether in such a case the collateral taker receives the top-up collateral, or whether it is left to the collateral provider’s general creditors. See paragraph 273 above and, for more information on the optional declaration

under Article 36(2), see the Declarations Memorandum, Section 4.H and accompanying Form No. 8 and OFFICIAL COMMENTARY, paragraphs 36-17, 36-20, and 36-26.

C. Matters to be addressed or clarified

1. Extra rights for collateral takers

286. The basic approach underlying Chapter V is that the liquidity of financial markets should be enhanced by eliminating traditional rules of private and insolvency law that strike a balance between collateral provider and collateral taker, and by extending extra rights to the collateral taker. Chapter V contains a minimum regime. Article 31(2) provides for the possibility that non-Convention law envisages additional rights and powers of collateral takers and additional obligations of collateral providers. However, in their decision to go beyond the minimum regime envisaged in Chapter V, lawmakers should take into account the lessons learnt during the global financial crisis (notably the debate on the effects of liberalisation and the necessity of regulatory intervention).

2. Commercial reasonableness

287. The concept of commercial reasonableness is key where securities need to be valued, notably in the context of enforcement. Article 35 determines that non-Convention rules regarding commercial reasonableness are not affected by the Convention rules on enforcement and the right of use. The content of the concept of commercial reasonableness is not specified in the Convention, and it is thus up to the domestic lawmaker to determine whether a specification of this content is necessary in the context of securities markets.

3. New regulatory framework

288. As mentioned in paragraphs 279-282, lawmakers should take into account new regulatory standards regarding securities financing transactions and other transactions involving financial collateral as developed by bodies such as the FSB and the Basel Committee for Banking Supervision on issues such as transparency, cash collateral reinvestment, the right of use or re-hypothecation, collateral valuation and management, minimum haircuts, indemnification-related risk, ipso facto clauses, and the regulatory stay. The same holds true for the more general debate on the pros and cons of the insolvency safe harbours. Ideally, when lawmakers devise rules for financial collateral transactions, they take into account both the lessons of the financial crisis (reflected in the new regulatory standards) and the policy considerations underlying the rules in Chapter V of the Convention.

4. Close-out netting

289. Lawmakers can find specific guidance on close-out netting in the UNIDROIT Principles on the Operation of Close-Out Netting Provisions. These Principles take the regulatory guidance on ipso facto clauses and the regulatory stay into account.

5. Secured transactions law

290. In case lawmakers decide not to adopt Chapter V as a whole, but only to draw inspiration from its provisions in structuring their legal framework, they could also look at the guidelines regarding general secured transactions law in the UNCITRAL Legislative Guide on Secured Transactions and the UNCITRAL Model Law on Secured Transactions. It should, however, be noted that the UNCITRAL Legislative Guide does not cover securities at all, whereas the UNCITRAL Model Law contains rules for non-intermediated securities only. Policy considerations relating to intermediated securities markets, such as those enshrined in the Geneva Securities Convention, therefore merit special attention. For example, besides the provisions of the UNCITRAL instruments on the creation of interests and their third party effectiveness, the considerations underlying Articles 11, 12 and 13 of the Geneva Securities Convention remain relevant.

Where priority contests are concerned, Articles 19 and 20 of the Convention should be considered and, in the case of enforcement, Articles 33 and 35 of the Convention should be taken into account.

VIII. CONFLICT OF LAWS ASPECTS

Legislative Principle #14: As the Convention does not contain conflict of laws rules, the law should establish clear and sound conflict of laws rules in relation to intermediated securities.

291. Many intermediated securities transactions take place in an international context and therefore entail the presence of foreign elements. For example, the issuer may be incorporated in another State, the securities may be governed by a foreign law or the holding chain may begin, pass through or end in another State. These situations could raise problems of conflict of laws.

292. Such problems are resolved by what are known as *conflict of laws rules*. These rules determine which State's law applies to a transaction or to one particular aspect of it. Conflict of laws rules usually employ one or more elements of the transaction, the so-called "connecting factor", to link the transaction or the legal issue to a particular State law.

293. The Convention establishes uniform rules on intermediated securities but does not completely eliminate problems of conflict of laws. Indeed, the Convention does not contain conflict of laws rules. Thus, its sphere of application is not determined by itself but by the conflict of laws rules applicable in each State (i.e. the conflict of laws rules of the forum).

294. As a result, adoption of the Convention or its incorporation into domestic law must therefore be accompanied by a set of clear and sound conflict of laws rules that reflect the reality of how securities are held and transferred. This is particularly important because – as the Convention is based on a core and functional harmonisation approach – it leaves various matters to be governed by State laws, and these laws may still vary to a large extent. With respect to these non-harmonised aspects, identification of the applicable law becomes critical.

295. This Part deals with conflict of laws, specifically (a) the Convention's sphere of application; (b) traditional conflict of laws rules and their modernisation; (c) the Convention's "tier-by-tier" approach and its interaction with conflict of laws rules; and (d) other conflict of laws rules.

A. The Convention's sphere of application

296. The Convention does not lay down conflict of laws rules. Its application is determined instead by the conflict of laws rules of the forum. This idea is stated in Article 2(a) of the Convention. The Convention applies whenever the conflict of laws rules of the forum designate the law in force in a Contracting State as the applicable law.

297. The reason for this approach is clear. In some systems, once the Convention has been ratified by a State or incorporated into its domestic law, it becomes part of the substantive domestic law of that State. Therefore, the Convention's rules will apply *insofar as* the substantive law of that State is the applicable law under the conflict of laws rules of the forum.

298. As a result, even if the forum is a Contracting State to the Convention, the Convention does not apply when its conflict of laws rules point to the law of a non-Contracting State as the law applicable on an issue. And *vice versa*, even if the forum is a non-Contracting State, the Convention will apply if the conflict of laws rules of the forum point to the law of a Contracting State as the applicable law. As an example, let us assume that State A is the forum state and its conflict of laws rules point to State B's law as applicable: if State B has ratified the Convention, the Convention will apply, regardless of whether State A has ratified the Convention.

299. Together with Article 2, Article 3 clarifies the effect of conflict of laws rules on declarations. Because the declarations established by the Convention are related to its substantive rules – mainly allowing Contracting States to opt into or out of the harmonising rules – the application of such declarations is also determined by the conflict of laws rules of the forum.

B. Traditional conflict of laws rules and their modernisation

300. The application of traditional conflict of laws rules to intermediated securities can give rise to difficulties. The law should therefore establish modernised conflict of laws rules to address the particularities raised when securities are not held directly but with an intermediary.

301. Traditional conflict of laws rules – mainly based on the *lex rei (cartae) sitae* principle – have not proved to be very useful for intermediated securities, because those rules entail the attribution of an artificial location to an asset which by its nature may have no physical manifestation. Furthermore, it has also resulted in legal uncertainty and serious practical difficulties, because a *prima facie* application of that principle may lead to the law of the State where the issuer of the securities is incorporated or where the original securities are physically held by a CSD or registered (“look-through approach”), even though the ultimate account holder is not registered there.

302. Therefore, some States have modernised their conflict of laws rules to go beyond that principle and offer a more appropriate solution taking into account the way intermediated securities are held and transferred. In the EU, for example, the Directives on Settlement Finality and Financial Collateral provide conflict of laws rules based on the Place of the Relevant Intermediary Approach (PRIMA), that is, the law of the place where the account holder’s relevant intermediary maintains the securities account for the account holder.

303. At the international level, the Hague Securities Convention, which was concluded on 5 July 2006, is the most important instrument. The Hague Securities Convention represents an evolution beyond the initial formulation of PRIMA in that it too is based upon the notion of the relevant intermediary. However, it avoids any attempt to locate where the relevant intermediary maintains the securities account and instead gives effect to an agreement on governing law between an account holder and its intermediary as long as a qualifying office requirement is met (“Hague approach”). Thus, the State law chosen by the parties is to apply only if the relevant intermediary has an office – involved in the maintenance of securities accounts – in that State. See Hague Securities Convention, Article 4.

C. The Convention’s “tier-by-tier” approach and its interaction with conflict of laws rules

304. The Convention relies on a “tier-by-tier” approach for intermediated securities holdings systems. Though the Convention does not, as discussed in Part III.A above, characterise the legal nature of the rights and interests arising from a credit of securities to a securities account, the Convention does view intermediated holding chains as made up of distinct relationships. In particular, it divides the holding chain into tiers and looks at each link in that chain: *for each account holder there is one, but only one, relevant intermediary*. The building blocks of the Convention are each relationship between an account holder and its relevant intermediary.

305. This substantive approach works well with a conflict of laws approach whereby the applicable law is determined separately for each tier of the chain of intermediaries (i.e. for each relationship between an account holder and its relevant intermediary), as is generally the case for approaches based on the notion of the relevant intermediary. There may only be one applicable law for each tier and, therefore, in a multi-tier structure there may be two or more layers of laws. And this perfectly suits a substantive law regime that focuses on establishing the rules governing each relationship.

Diagram 305-1: Application of law in an intermediated securities holding chain spanning three States

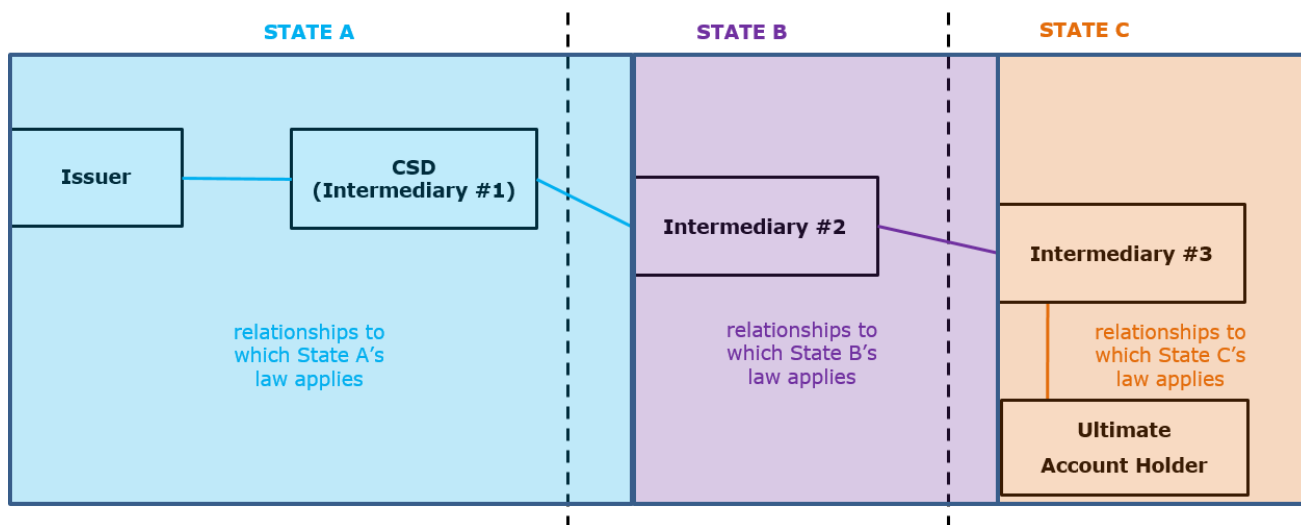

Let us imagine that intermediary #1 is in State A, intermediary #2 is in State B and intermediary #3 is in State C. According to either the initial formulation of PRIMA or Hague approach: (a) the law governing the rights of the ultimate account holder vis-à-vis the securities account maintained by intermediary #3 is State C's law, (b) the law governing the rights of intermediary #3 vis-à-vis the securities account maintained by intermediary #2 is State B's law; (c) and the law governing the rights of intermediary #2 vis-à-vis the securities account maintained by intermediary #1 is State A's law. *There are, therefore, three layers of rights, each set of which is governed by a different law.* It can be said that the ultimate account holder has a set of rights governed by State C's law over a set of rights acquired by intermediary #3 with intermediary #2 under State B's law, and over a set of rights acquired by intermediary #2 with intermediary #1 under State A's law.

306. Lawmakers should modernise the conflict of laws rules to avoid the ambiguities raised by traditional solutions (i.e. the *lex rei (carta) sitae* principle), and introduce a solution based on the relevant intermediary as the main connecting factor. Additionally a specification of that solution may be recommendable, focused on either (a) an objective element, the location of the securities account; or (b) a subjective element, an agreement between the account holder and the relevant intermediary.

307. In transparent systems, in particular, lawmakers should be aware that additional clarifications may be required. In principle, in these systems, the "relevant intermediary" for the purpose of determining the applicable law may be the CSD, where the accounts are maintained in the name of the ultimate investors.

D. Other conflict of laws rules

308. Both the initial formulation of PRIMA and Hague approach determine the law applicable to intermediated securities, but only for certain issues; for example, in the Hague Securities Convention, only for the issues enumerated in its Article 2(1)(a)-(g). If according to the Hague Securities Convention, the law applicable is that of a Contracting State to the Geneva Securities Convention, the Geneva Securities Convention would govern all substantive issues included in Article 2(1)(a)-(g) of the former.

309. However, the substantive scope of application of the Hague Securities Convention is not exactly the same as the substantive scope of the Geneva Securities Convention. Article 2(1)(a)-(g) of the Hague Securities Convention contains an exhaustive list of all the issues falling within the scope of the Hague Securities Convention, which is narrower than the scope of the Geneva Securities Convention. Although the concept is avoided, the Hague Securities Convention applies mainly to "proprietary" issues. However, purely contractual or personal rights which arise solely from the contractual relationship between the account holder and its intermediary or the parties to a disposition *inter se* are not included within the scope of the Hague Securities Convention. See Hague Securities Convention, Article 2(3)(a)).

310. The law applicable to other issues that are outside the substantive scope of the Hague Securities Convention but which may fall within the scope of the Geneva Securities Convention is determined by the corresponding conflict of laws rules of the forum. For example, the law applicable to the contractual obligations of the intermediary vis-à-vis its account holder is determined by the conflict of laws rules on contractual obligations. In the EU, this is the Rome I Regulation, which is based on the principle of party autonomy (“A contract shall be governed by the law chosen by the parties”). The same principle inspires the Hague Principles on Choice of Law in International Commercial Contracts. In application of this principle, if the law chosen by the parties is that of a Contracting State to the Geneva Securities Convention, the provisions of that instrument on contractual obligations (e.g. Article 10) would apply.

311. Finally, the determination of the law applicable in insolvency proceedings (i.e. “insolvency conflict of laws rules”) should be designed to ensure the effectiveness of the rights over intermediated securities in such proceedings as established, in particular, by Articles 14 and 21 of the Convention. See, e.g., Hague Securities Convention, Article 8.

IX. OTHER INSTRUMENTS AND REGULATIONS AND IMPLEMENTATION

Legislative Principle #15: Lawmakers should consider the various instruments and guidance that is available in order to develop and implement an intermediated securities holding system which is tailored to their legal and economic context and consistent with the principles and rules contained in the Guide.

312. It is important for lawmakers to consider the links between the Geneva Securities Convention and other international instruments and how best to implement changes made in order to create or improve an intermediated securities holding system. Other instruments and guidance documents are available for consideration in establishing or evaluating an intermediated securities holding system, which is just one important part of a State’s broader and interconnected financial system. States should consider the various instruments and documents available – which may address particular aspects in greater detail – in order to tailor and implement legal reforms which correspond best to their system and are consistent with the principles and rules set forth in the Guide.

A. *Links to other international instruments or regulations*

313. The modernisation of domestic legislation on financial markets is essential to a State’s economic development. At the international level, many standard-setting bodies have adopted standards to ensure financial stability and mitigate risk, to improve efficiency and to favour cross-border transactions. The FSB, for instance, keeps a regularly-updated compendium of standards relating to financial markets. In particular, the FSB selected a number of “Key Standards for Sound Financial Systems” (“FSB Key Standards”), concerning three macro-areas: (a) macroeconomic policy and data transparency, (b) financial regulation and supervision, and (c) institutional and market infrastructure. These are elaborated by different international standard-setting bodies, according to relevant competences, but are jointly used as a basis for evaluation of the soundness of a State (e.g. FSAP by the IMF and the World Bank are based on those standards).

314. On the one hand, these exercises are done to reduce systemic risk and to prevent financial distress from spreading from one State to another, but also to support investment and reinforce the infrastructure of domestic markets. On the other hand, emerging markets offer extremely interesting opportunities for foreign investments, which in turn may favour the development of domestic sectors of the economy. In order to strengthen their internal markets, as well as incentivise foreign investments by accruing trust, States endeavour to sustain their own economies with adequate infrastructures according to such standards.

315. International standards consider as a first requirement to attaining the above objectives of development and stability that a sound legal system be in place. For instance, Principle One of the Principles

for Financial Market Infrastructures, which are included in the FSB Key Standards, establishes that any FMI needs to have a sound legal basis. This requirement, however, should not be simply interpreted as meaning that legal obstacles to the working of specific systems or business schemes be eliminated. This is of course one of the priorities to reduce risk and its diffusion to foreign markets, but it cannot stand alone. A State needs to have modern legislation that offers a legally sound environment, conducive to modernisation, and in which operators can act on a level playing field while relevant interests are duly protected and stability is adequately taken care of. International standards not only require elimination of legal barriers, but also the building of a sound legal environment conducive to development and stability.

316. Many States use international standards, and in particular those concerning or affecting their internal legal order, as an effective benchmark for reform. On the other hand, it is generally understood that a State that respects international standards and possesses a sound legal environment receives positive rankings in the various international comparative exercises that are performed by international bodies (such as the World Bank's Doing Business reports), which can make a difference regarding foreign investments actually received in a State because respect of such standards has proven to favour concretely market development and ensure stability. The World Bank's Doing Business reports, for example, include evaluation of the legal environment of a State in many contexts, and uses international Conventions and other international instruments for harmonisation as benchmarks.

317. Indeed, the exercises done at the international level by international organisations and bodies to harmonise domestic legislation in specific fields has the objective, among others, to provide guidance in this direction, and offer models that are the result of international harmonisation. It is not a specific State's model that is diffused by these bodies, but the synthesis of various legal experiences and traditions. Because of this, they usually reflect balanced solutions, to be taken into serious consideration in any domestic reform efforts.

318. The adoption of international instruments such as the Geneva Securities Convention is thus a fundamental step within a wider scenario of domestic legal reforms for modernisation and openness of a State's economy using international standards as benchmarks, and international instruments for harmonisation of law as the most balanced and unbiased models to be used to that end.

B. Overview of implementation in a domestic legal framework

319. Each State has its own tradition and is situated within a specific regional context. As a result, each needs to implement a tailor-made legal reform. However, there are high-level principles that are usually recognised as commonly shared, and thus included in international instruments. When principles are generally shared and can be sufficiently detailed, a Convention is adopted. In other cases, a Model Law or a Legislative Guide is issued because these instruments, although not offering hard law solutions, permit convergence by leaving more flexibility in the means to be used to reach such convergence.

320. Ways to adopt a Convention, a Model Law or a Legislative Guide into a domestic legal order are different, but in all cases the international instrument has to be understood within the more general context of both other fields of legislation that are not covered by the specific international instrument, and the institutional and legal order of the State, with its own existing legal tradition and institutions.

321. As mentioned, in the case of financial markets, various international standards and measures of a regulatory nature exist. The Convention recognises this variety and excludes such matters from its own scope, as it does for other matters of a purely legal nature (such as corporate law).

322. However, these regulations and standards need to be considered by the domestic lawmaker not only to avoid the risk of leaving essential aspects unregulated, but also because each piece of reform needs to be drafted in a consistent manner and policy choices taken as much as possible under an holistic approach. When other international instruments exist in these fields, these need to be adequately implemented. When international standards do not exist, there is still a need for modernisation, and the State should rely on

its own general principles of law and institutional framework. This may involve cooperation by many public bodies in the State according to their individual functions and scope of responsibility.

323. While corporate law generally does not fall within the Convention's scope, that law affects the working of book-entry systems for securities and some rights and duties of account holders found in such body of law might unpredictably affect the application of the Convention. In the same vein, rules on money laundering or market abuse, which are excluded by the scope of the Convention, need to be put in place if concrete modernisation is to be achieved.

324. Finally, legal reform coming from international instruments may require the adoption of articulated implementing measures. Indeed, international rules may be better reflected in a legal system by way of a statutory act, a secondary measure, contractual agreements by the market, or finally a combination of these options. Adoption of a reform not only implies evaluation of rules to be adopted into a legal system, amendment of existing specific provisions or adaptation of legal institutions, but also determination of the most appropriate legal mechanisms to be adopted. For example, for legal reforms by statutory act, there are two main approaches. First, a statutory act could address the core aspects of an intermediated securities holding system and then cross-reference to the relevant statutes or authority on related aspects, such as innocent purchasers or insolvency. Second, a standalone statutory act on intermediated securities could be developed, which addresses comprehensively all the necessary aspects in an intermediated securities holding system. For newer or lesser developed securities markets, the latter approach could enhance the attractiveness of a particular market by clearly laying out the applicable legal framework and thereby reducing the perceived legal risk.

325. With respect to undertaking reforms consistent with the Convention and the Guide, there are two aspects that need to be kept in mind. First, in creating or evaluating an intermediated securities holding system, a State could use the Guide, for example, to prepare for signing and adopting the Convention or to select and implement all or certain principles and rules set forth in the Guide. Signature and adoption of the Convention, however, may be a State's preferred option, as the Convention offers the advantage of a streamlined, functional, core package of principles and rules governing intermediated securities. As discussed throughout the Guide, if the Convention is signed and is to be adopted, a Contracting State may need to make certain declarations under the Convention and address or clarify certain aspects of law outside the Convention. Regarding declarations specifically, they include not only those discussed above in the relevant subsections entitled "Choices to be made by declaration", but also those concerning technical treaty matters, in particular competence of Regional Economic Integration Organisations under Article 41(2) and territorial units under Article 43. For more information on these latter declarations, see the Declarations Memorandum, Sections 4.K and 4.L and accompanying Forms No. 11 and No. 12 respectively. Whether a State opts to sign and adopt the Convention or to select and implement the Convention's principles and rules, legal certainty and economic efficiency would be enhanced.

326. Second, for the specific matters governed by the Convention, some provisions might need to be included in a statutory act, because they would establish rights and obligations against third parties. Other provisions can be addressed by regulations or other secondary measures by relevant authorities. This is surely the case for regulatory matters outside the scope of the Convention but still to be covered by a wider legal reform of the sector. In this case, as briefly mentioned, the issue gives rise to the question of which relevant authorities would be competent for such exercise. Standard contractual rules by the market are often the best normative tool, as the Convention recognises in the case of internal rules of securities systems or other bodies, usually authorised to operate following satisfaction of various conditions verified by the regulator. All these choices need to be made not only according to principles of efficiency but also in light of the existing institutional framework of the State.

327. Whereas technical assistance can substantially help the State to consider all of these elements and address them consistently and in light of international best practice, the reform belongs to the individual State and is its own product, as a result of efforts usually involving many domestic stakeholders.

ANNEX 1

LIST OF LEGISLATIVE PRINCIPLES

#1 (Rights of account holders): The Convention provides any account holder with a core set of rights resulting from the credit of securities to a securities account. The law should establish additional rights consistent with how it characterises the legal position of account holders. It may distinguish between the rights enjoyed by an investor (including an intermediary acting for its own account) and those accruing to an intermediary acting in its capacity of intermediary.

#2 (Measures to enable the exercise of rights of account holders): The Convention provides one general and four specific obligations of intermediaries to their account holders. The law should establish specific contents for these duties and, if necessary, expand them in a manner consistent with its own characterisation of an account holder's legal position. The law should also specify the manner in which an intermediary may comply with its obligations and determine the conditions under which an intermediary becomes liable. In transparent systems, where intermediary functions are shared between the CSD and account operators, the law should clearly allocate the respective responsibilities, and the Contracting State must make a declaration in this respect.

#3 (Liability of intermediaries): The Convention does not specify the liability of intermediaries. The law should clearly establish the conditions and the extent of such liability, and whether it may be exempted by way of contractual provisions.

#4 (Acquisition and disposition of intermediated securities): The Convention provides that intermediated securities or any limited interests therein may be transferred by debits and credits. The law also may adopt any one or more of the other methods specified by the Convention.

#5 (Unauthorised dispositions and invalidity, reversal and conditions): The Convention provides that an intermediary may only dispose of intermediated securities with the authorisation of the person(s) affected by the disposition. The law may provide for other cases of authorised dispositions, and it should establish the consequences of unauthorised dispositions. The law should also determine whether and in what circumstances a book entry is invalid, reversible, or conditional, and the consequences thereof.

#6 (Protection of an innocent acquirer): The Convention provides that an innocent acquirer who acquires for value is protected against adverse claims. This protection covers instances in which (a) another person has an interest in intermediated securities which is violated by the acquisition, and (b) the acquisition could be affected by an earlier defective entry. The law may extend the scope of this protection.

#7 (Priorities): The Convention provides clear priority rules that apply among competing claimants to the same intermediated securities. The law may supplement and adjust these priority rules. The law should address priority contests that are not resolved by the Convention.

#8 (Prohibition of upper-tier attachment): The Convention, with limited exceptions, prohibits any attachment of intermediated securities of an account holder against, or so as to affect (a) a securities account of any person other than that account holder, (b) the issuer of any securities credited to a securities account of that account holder, or (c) a person other than the account holder and the relevant intermediary.

#9 (Prevention of shortfalls and allocation of securities): The Convention requires intermediaries to prevent shortfalls, notably by holding or having available sufficient securities to cover credits to securities accounts that these intermediaries maintain. The law should regulate the method, manner, and time frame for compliance.

The Convention also requires intermediaries to allocate securities to account holders' rights. The law may establish a specific form of segregation as a method of allocation.

#10 (Securities clearing and settlement systems): The Convention recognises the systemic importance of securities clearing or settlement systems, and in some instances allows derogations to the rules of the Convention to the extent permitted by the law applicable to the system. The law should only allow for derogations to the Convention rules where such derogations are necessary to ensure the integrity of the local securities clearing or settlement systems.

The law should clearly determine when an instruction or a transaction within a securities clearing or settlement system becomes irrevocable and final, notwithstanding the insolvency of the operator of the system or one of its participants.

#11 (Issuers): The Convention generally does not deal with the relationships between account holders and issuers. The law should clearly define the persons entitled to exercise the rights attached to the securities vis-à-vis the issuer and the conditions for such exercise. The law should facilitate the exercise of those rights by the ultimate account holder, in particular, by allowing intermediaries who act on behalf of third parties (nominees) to exercise voting rights or other rights in different ways, and should recognise holding through nominees.

In the insolvency proceeding of an issuer, the Convention provides that such an account holder is not precluded from exercising a right of set-off merely because it holds securities through intermediaries.

#12 (Insolvency protection): The Convention establishes important insolvency proceeding-related rules on the interests made effective against third-parties and provides loss-sharing rules in case of a shortfall of account holder securities. However, the law should address many other important and relevant features of insolvency and regulatory law that the Convention leaves to it.

#13 (Special provisions in relation to collateral transactions): The law should establish clear and sound rules in relation to collateral transactions involving intermediated securities. The Convention provides optional rules in relation to such transactions, whether by way of security collateral agreement or title transfer collateral agreement. Other international instruments and documents, reflecting lessons of the financial crisis, provide further guidance on regulatory, private and insolvency law issues involved.

#14 (Conflict of laws aspects): As the Convention does not contain conflict of laws rules, the law should establish clear and sound conflict of laws rules in relation to intermediated securities.

#15 (Implementation and other instruments and regulations): Lawmakers should consider the various instruments and guidance that is available in order to develop and implement an intermediated securities holding system which is tailored to their legal and financial context and consistent with the principles and rules contained in the Guide.

ANNEX 2

REFERENCES TO “NON-CONVENTION LAW”

References in the Convention	For discussion
<p>Preamble, recital 7:</p> <p><i>HAVING due regard for <u>non-Convention law</u> in matters not determined by this Convention,</i></p>	<p>OFFICIAL COMMENTARY:</p> <p>Para P-8</p>
<p>Article 1(k):</p> <p><i>“control agreement” means an agreement in relation to intermediated securities between an account holder, the relevant intermediary and another person or, if so provided by the <u>non-Convention law</u>, between an account holder and the relevant intermediary or between an account holder and another person of which the relevant intermediary receives notice, which includes either or both of the following provisions: [...]</i></p>	<p>OFFICIAL COMMENTARY:</p> <p>Paras 1-52, 1-54</p> <p>Legislative Guide:</p> <p>Paras 141 to 146</p>
<p>Article 1(l):</p> <p><i>“designating entry” means an entry in a securities account made in favour of a person (including the relevant intermediary) other than the account holder in relation to intermediated securities, which, under the account agreement, a control agreement, the uniform rules of a securities settlement system or the <u>non-Convention law</u>, has either or both of the following effects: [...]</i></p>	<p>OFFICIAL COMMENTARY:</p> <p>Paras 1-53 to 1-54</p> <p>Legislative Guide:</p> <p>Paras 141 to 146</p>
<p>Article 1(m):</p> <p><i>“non-Convention law” means the law in force in the Contracting State referred to in Article 2, other than the provisions of this Convention;</i></p>	<p>OFFICIAL COMMENTARY:</p> <p>Paras 1-55 to 1-60</p> <p>Legislative Guide:</p> <p>Para 75</p>
<p>Article 1(p):</p> <p><i>“uniform rules” means, in relation to a securities settlement system or securities clearing system, rules of that system (including system rules constituted by the <u>non-Convention law</u>) which are common to the participants or to a class of participants and are publicly accessible.</i></p>	<p>OFFICIAL COMMENTARY:</p> <p>Paras 1-100 to 101</p> <p>Legislative Guide:</p> <p>Para 75</p>
<p>Article 7(1):</p> <p><i>A Contracting State may declare that under its <u>non-Convention law</u> a person other than the relevant intermediary is responsible for the performance of a function or functions (but not all functions) of the relevant intermediary under this Convention, either generally or in relation to intermediated securities, or securities accounts, of any category or description.</i></p>	<p>OFFICIAL COMMENTARY:</p> <p>Para 7-19</p> <p>Legislative Guide:</p> <p>Paras 103, 203 to 207</p> <p>Declarations Memorandum:</p> <p>Section 4.C and accompanying Forms 3.A and 3.B</p>
<p>Article 9(1)(a)(ii):</p> <p><i>The credit of securities to a securities account confers on the account holder:</i></p> <p><i>(a) the right to receive and exercise any rights attached to the securities, including in particular dividends, other distributions and voting rights: (i) if the account holder is not an intermediary or is an intermediary acting for its own account; and (ii) in any other case, if so provided by the <u>non-Convention law</u>;</i></p>	<p>OFFICIAL COMMENTARY:</p> <p>Para 9-16</p> <p>Legislative Guide:</p> <p>Paras 82, 88 to 93</p>

<p>Article 9(1)(c):</p> <p><i>The credit of securities to a securities account confers on the account holder: [...] (c) the right, by instructions to the relevant intermediary, to cause the securities to be held otherwise than through a securities account, to the extent permitted by the applicable law, the terms of the securities and, to the extent permitted by the <u>non-Convention law</u>, the account agreement or the uniform rules of a securities settlement system;</i></p>	<p>OFFICIAL COMMENTARY:</p> <p>Paras 9-21 to 9-26</p> <p>Legislative Guide:</p> <p>Paras 82 et seq., 236</p>
<p>Article 9(1)(d):</p> <p><i>The credit of securities to a securities account confers on the account holder: [...] (d) unless otherwise provided in this Convention, such other rights, including rights and interests in securities, as may be conferred by the <u>non-Convention law</u>.</i></p>	<p>OFFICIAL COMMENTARY:</p> <p>Paras 9-27 to 9-30</p> <p>Legislative Guide:</p> <p>Paras 82, 88 et seq.</p>
<p>Article 9(3):</p> <p><i>If an account holder has acquired a security interest, or a limited interest other than a security interest, by credit of securities to its securities account under Article 11(4), the <u>non-Convention law</u> determines any limits on the rights described in paragraph 1 of this Article.</i></p>	<p>OFFICIAL COMMENTARY:</p> <p>Paras 9-31 to 9-33</p> <p>Legislative Guide:</p> <p>Paras 82, 88, 94 to 97</p>
<p>Article 10(2)(c), (e), and (f):</p> <p><i>An intermediary must, at least: [...] (c) give effect to any instructions given by the account holder or other authorised person, as provided by the <u>non-Convention law</u>, the account agreement or the uniform rules of a securities settlement system; [...] (e) regularly pass on to account holders information relating to intermediated securities, including information necessary for account holders to exercise rights, if provided by the <u>non-Convention law</u>, the account agreement or the uniform rules of a securities settlement system; and (f) regularly pass on to account holders dividends and other distributions received in relation to intermediated securities, if provided by the <u>non-Convention law</u>, the account agreement or the uniform rules of a securities settlement system.</i></p>	<p>OFFICIAL COMMENTARY:</p> <p>Paras 10-10, 10-13, 10-15 to 10-17</p> <p>Legislative Guide:</p> <p>Paras 101 to 119, 221</p>
<p>Article 11(2):</p> <p><i>No further step is necessary, or may be required by the <u>non-Convention law</u> or any other rule of law applicable in an insolvency proceeding, to render the acquisition of intermediated securities effective against third parties.</i></p>	<p>OFFICIAL COMMENTARY:</p> <p>Paras 11-17 to 11-19</p> <p>Legislative Guide:</p> <p>Paras 125, 131</p>
<p>Article 12(2):</p> <p><i>No further step is necessary, or may be required by the <u>non-Convention law</u> or any other rule of law applicable in an insolvency proceeding, to render the acquisition of intermediated securities effective against third parties.</i></p>	<p>OFFICIAL COMMENTARY:</p> <p>Para 12-31, which also refers to paras 11-17 to 11-19</p> <p>Legislative Guide:</p> <p>Para 138</p>
<p>Article 13:</p> <p><i>This Convention does not preclude any method provided by the <u>non-Convention law</u> for: (a) the acquisition or disposition of intermediated securities or of an interest in intermediated securities; or (b) the creation of an interest in intermediated securities and for making such an interest effective against third parties, other than the methods provided by Articles 11 and 12.</i></p>	<p>OFFICIAL COMMENTARY:</p> <p>Paras 13-5 to 13-6</p> <p>Legislative Guide:</p> <p>Paras 138 to 140, 155 to 157, 183, 188, 197, 254</p>
<p>Article 15(1)(e):</p> <p><i>An intermediary may make a debit of securities to a securities account, make or remove a designating entry or otherwise dispose of intermediated securities only if it is authorised to do so: [...] (e) by the <u>non-Convention law</u>.</i></p>	<p>OFFICIAL COMMENTARY:</p> <p>Para 15-17</p> <p>Legislative Guide:</p> <p>Para 160 et seq.</p>

<p>Article 15(2):</p> <p><i>The non-Convention law and, to the extent permitted by the <u>non-Convention law</u>, the account agreement or the uniform rules of a securities settlement system determine the consequences of: an unauthorised debit; an unauthorised removal of a designating entry; subject to Article 18(2), an unauthorised designating entry; or any other unauthorised disposition.</i></p>	<p>OFFICIAL COMMENTARY: Paras 15-18 to 15-21</p> <p>Legislative Guide: Paras 160 to 171</p>
<p>Article 16:</p> <p><i>Subject to Article 18, the <u>non-Convention law</u> and, to the extent permitted by the non-Convention law, the account agreement or the uniform rules of a securities settlement system determine whether and in what circumstances a debit, credit, designating entry or removal of a designating entry is invalid, is liable to be reversed or may be subject to a condition, and the consequences thereof.</i></p>	<p>OFFICIAL COMMENTARY: Paras 16-9 to 16-23</p> <p>Legislative Guide: Paras 160 to 171, 221</p>
<p>Article 18(5):</p> <p><i>To the extent permitted by the <u>non-Convention law</u>, paragraph 2 is subject to any provision of the uniform rules of a securities settlement system or of the account agreement.</i></p>	<p>OFFICIAL COMMENTARY: Paras 18-11 to 18-14</p> <p>Legislative Guide: Paras 172, 221</p>
<p>Article 19(2):</p> <p><i>Subject to paragraph 5 and Article 20, interests that become effective against third parties under Article 12 have priority over any interest that becomes effective against third parties by any other method provided by the <u>non-Convention law</u>.</i></p>	<p>OFFICIAL COMMENTARY: Para 19-13</p> <p>Legislative Guide: Paras 183 to 184</p>
<p>Article 19(7):</p> <p><i>A Contracting State may declare that under its <u>non-Convention law</u>, subject to paragraph 4, an interest granted by a designating entry has priority over any interest granted by any other method provided by Article 12.</i></p>	<p>OFFICIAL COMMENTARY: Para 19-17</p> <p>Legislative Guide: Paras 153, 189</p> <p>Declarations Memorandum: Section 4.E and accompanying Form No. 5</p>
<p>Article 22(3):</p> <p><i>A Contracting State may declare that under its <u>non-Convention law</u> an attachment of intermediated securities of an account holder made against or so as to affect a person other than the relevant intermediary has effect also against the relevant intermediary. Any such declaration shall identify that other person by name or description and shall specify the time at which such an attachment becomes effective against the relevant intermediary.</i></p>	<p>OFFICIAL COMMENTARY: Paras 22-19 to 22-22</p> <p>Legislative Guide: Paras 203 to 208</p> <p>Declarations Memorandum: Section 4.F and accompanying Form No. 6</p>
<p>Article 23(2)(d):</p> <p><i>Paragraph 1 [which states that "[a]n intermediary is neither bound nor entitled to give effect to any instructions in relation to intermediated securities of an account holder given by any person other than that account holder"] is subject to: [...] (d) any applicable provision of the <u>non-Convention law</u>; and</i></p>	<p>OFFICIAL COMMENTARY: Paras 23-26 to 23-27</p> <p>Legislative Guide: Paras 106, 114-117</p>
<p>Article 24(3):</p> <p><i>If at any time the requirements of paragraph 1 are not complied with, the intermediary must within the time permitted by the <u>non-Convention law</u> take such action as is necessary to ensure compliance with those requirements.</i></p>	<p>OFFICIAL COMMENTARY: Paras 24-20 to 24-21</p> <p>Legislative Guide: Para 217</p>

<p>Article 24(4):</p> <p><i>This Article does not affect any provision of the <u>non-Convention law</u>, or, to the extent permitted by the <u>non-Convention law</u>, any provision of the uniform rules of a securities settlement system or of the account agreement, relating to the method of complying with the requirements of this Article or the allocation of the cost of ensuring compliance with those requirements or otherwise relating to the consequences of failure to comply with those requirements.</i></p>	<p>OFFICIAL COMMENTARY:</p> <p>Para 24-22</p> <p>Legislative Guide:</p> <p>Para 218</p>
<p>Article 25(3):</p> <p><i>The allocation required by paragraph 1 shall be effected by the <u>non-Convention law</u> and, to the extent required or permitted by the <u>non-Convention law</u>, by arrangements made by the relevant intermediary.</i></p>	<p>OFFICIAL COMMENTARY:</p> <p>Para 25-15</p> <p>Legislative Guide:</p> <p>Para 213</p>
<p>Article 25(5):</p> <p><i>A Contracting State may declare that, if all securities and intermediated securities held by an intermediary for its account holders, other than itself, are in segregated form under arrangements such as are referred to in paragraph 4, under its <u>non-Convention law</u> the allocation required by paragraph 1 applies only to those securities and intermediated securities and does not apply to securities and intermediated securities held by an intermediary for its own account.</i></p>	<p>OFFICIAL COMMENTARY:</p> <p>Paras 25-19 to 25-20</p> <p>Legislative Guide:</p> <p>Paras 212, 215, 261, 269</p> <p>Declarations Memorandum:</p> <p>Section 4.G and accompanying Form No. 7</p>
<p>Article 26(3):</p> <p><i>To the extent permitted by the <u>non-Convention law</u>, if the intermediary is the operator of a securities settlement system and the uniform rules of the system make provision in case of a shortfall, the shortfall shall be borne in the manner so provided.</i></p>	<p>OFFICIAL COMMENTARY:</p> <p>Para 26-12</p> <p>Legislative Guide:</p> <p>Para 221</p>
<p>Article 28(1) and (2):</p> <p><i>(1) The obligations of an intermediary under this Convention, including the manner in which an intermediary complies with its obligations, may be specified by the <u>non-Convention law</u> and, to the extent permitted by the <u>non-Convention law</u>, the account agreement or the uniform rules of a securities settlement system.</i></p> <p><i>(2) If the substance of any such obligation is specified by the <u>non-Convention law</u> or, to the extent permitted by the <u>non-Convention law</u>, the account agreement or the uniform rules of a securities settlement system, compliance with it satisfies that obligation.</i></p>	<p>OFFICIAL COMMENTARY:</p> <p>Paras 28-10 to 28-13</p> <p>Legislative Guide:</p> <p>Paras 106, 118 to 119, 221</p>
<p>Article 28(3):</p> <p><i>The liability of an intermediary in relation to its obligations is governed by the <u>non-Convention law</u> and, to the extent permitted by the <u>non-Convention law</u>, the account agreement or the uniform rules of a securities settlement system.</i></p>	<p>OFFICIAL COMMENTARY:</p> <p>Paras 28-15 to 28-17</p> <p>Legislative Guide:</p> <p>Paras 106, 120 to 122, 221</p>
<p>Article 31(2):</p> <p><i>Nothing in this Chapter impairs any provision of the <u>non-Convention law</u> which provides for additional rights or powers of a collateral taker or additional obligations of a collateral provider.</i></p>	<p>OFFICIAL COMMENTARY:</p> <p>Paras 31-17 to 31-18</p> <p>Legislative Guide:</p> <p>Para 286</p>
<p>Article 34(4):</p> <p><i>The exercise of a right of use shall not render invalid or unenforceable any right of the collateral taker under the relevant security collateral agreement or the <u>non-Convention law</u>.</i></p>	<p>OFFICIAL COMMENTARY:</p> <p>Para 34-17</p> <p>Legislative Guide:</p> <p>Para 277</p>

<p>Article 35:</p> <p><i>Articles 33 and 34 do not affect any requirement of the <u>non-Convention law</u> to the effect that the realisation or valuation of collateral securities or the calculation of any obligations must be conducted in a commercially reasonable manner.</i></p>	<p>OFFICIAL COMMENTARY:</p> <p>Paras 35-8 to 35-11</p> <p>Legislative Guide:</p> <p>Para 287</p>
<p>Article 36(1)(a)(iii):</p> <p><i>If a collateral agreement includes: (a) an obligation to deliver additional collateral securities: [...] (iii) to the extent permitted by the non-Convention law, in any other circumstances specified in the collateral agreement; or</i></p>	<p>OFFICIAL COMMENTARY:</p> <p>Para 36-21</p> <p>Legislative Guide:</p> <p>Para 285</p>

ANNEX 3

REFERENCES TO “APPLICABLE LAW”

References in the Convention	For discussion
<p>Article 2(a): <i>This Convention applies whenever: (a) the applicable conflict of laws rules designate the law in force in a Contracting State as the <u>applicable law</u>;</i></p>	<p>OFFICIAL COMMENTARY: Paras 2-6 to 2-9 Legislative Guide: Para 296</p>
<p>Article 3: <i>If the law of the forum State is not the <u>applicable law</u>, the forum State shall apply the Convention and the declarations, if any, made by the Contracting State the law of which applies, and without regard to the declarations, if any, made by the forum State.</i></p>	<p>OFFICIAL COMMENTARY: Paras 3-5 to 3-7 Legislative Guide: Para 299</p>
<p>Article 9(1)(c): <i>The credit of securities to a securities account confers on the account holder: [...] (c) the right, by instructions to the relevant intermediary, to cause the securities to be held otherwise than through a securities account, to the extent permitted by the <u>applicable law</u>, the terms of the securities and, to the extent permitted by the non-Convention law, the account agreement or the uniform rules of a securities settlement system;</i></p>	<p>OFFICIAL COMMENTARY: Paras 9-8, 9-21 to 9-26 Legislative Guide: Paras 82, 236</p>
<p>Article 9(2)(b): <i>Unless otherwise provided in this Convention: [...] (b) the rights referred to in paragraph 1(a) may be exercised against the relevant intermediary or the issuer of the securities, or both, in accordance with this Convention, the terms of the securities and the <u>applicable law</u>;</i></p>	<p>OFFICIAL COMMENTARY: Para 9-17 Legislative Guide: Paras 100 to 101</p>
<p>Article 12(8): <i>The <u>applicable law</u> determines in what circumstances a non-consensual security interest in intermediated securities may arise and become effective against third parties.</i></p>	<p>OFFICIAL COMMENTARY: Para 12-20 Legislative Guide: Para 159</p>
<p>Article 18(4): <i>If an acquirer is not protected by paragraph 1 or paragraph 2, the <u>applicable law</u> determines the rights and liabilities, if any, of the acquirer.</i></p>	<p>OFFICIAL COMMENTARY: Paras 18-17 to 18-18 Legislative Guide: Para 178</p>
<p>Article 19(5): <i>A non-consensual security interest in intermediated securities arising under the <u>applicable law</u> has such priority as is afforded to it by that law.</i></p>	<p>OFFICIAL COMMENTARY: Para 19-15 Legislative Guide: Paras 192 to 195</p>
<p>Article 19(6): <i>As between persons entitled to any interests referred to in paragraphs 2, 3 and 4 and, to the extent permitted by the <u>applicable law</u>, paragraph 5, the priorities provided by this Article may be varied by agreement between those persons, but any such agreement does not affect third parties.</i></p>	<p>OFFICIAL COMMENTARY: Para 19-16 Legislative Guide: Para 187</p>

ANNEX 4

REFERENCES TO RULES RELATING TO INSOLVENCY

References in the Convention	For discussion
<p>Preamble, recital 9:</p> <p><i>Emphasising that this Convention is not intended to harmonise or otherwise affect <u>insolvency law</u> except to the extent necessary to provide for the effectiveness of rights and interests governed by this Convention,</i></p>	<p>OFFICIAL COMMENTARY:</p> <p>Para P-10</p>
<p>Article 1(h):</p> <p><i>"insolvency proceeding" means a collective judicial or administrative proceeding, including an interim proceeding, in which the assets and affairs of the debtor are subject to control or supervision by a court or other competent authority for the purpose of reorganisation or liquidation;</i></p>	<p>OFFICIAL COMMENTARY:</p> <p>Para 1-46</p>
<p>Article 1(i):</p> <p><i>"insolvency administrator" means a person (including a debtor in possession if applicable) authorised to administer an <u>insolvency proceeding</u>, including one authorised on an interim basis;</i></p>	<p>OFFICIAL COMMENTARY:</p> <p>Para 1-47</p>
<p>Article 11(2):</p> <p><i>No further step is necessary, or may be required by the non-Convention law or any other rule of law applicable in an <u>insolvency proceeding</u>, to render the acquisition of intermediated securities effective against third parties.</i></p>	<p>OFFICIAL COMMENTARY:</p> <p>Paras 11-17 to 11-19</p> <p>Legislative Guide:</p> <p>Paras 125, 131</p>
<p>Article 12(2):</p> <p><i>No further step is necessary, or may be required by the non-Convention law or any other rule of law applicable in an <u>insolvency proceeding</u>, to render the interest effective against third parties.</i></p>	<p>OFFICIAL COMMENTARY:</p> <p>Para 12-12</p> <p>Legislative Guide:</p> <p>Para 138 et seq.</p>
<p>Article 14(2):</p> <p><i>Paragraph 1 [which states that "[r]ights and interests that have become effective against third parties under Article 11 or Article 12 are effective against the insolvency administrator and creditors in any insolvency proceeding] does not affect the application of any substantive or procedural rule of law applicable by virtue of an <u>insolvency proceeding</u>, such as any rule relating to: (a) the ranking of categories of claims; (b) the avoidance of a transaction as a preference or a transfer in fraud of creditors; or (c) the enforcement of rights to property that is under the control or supervision of the insolvency administrator.</i></p>	<p>OFFICIAL COMMENTARY:</p> <p>Para 14-6 to 14-11</p> <p>Legislative Guide:</p> <p>Para 252</p>
<p>Article 21:</p> <p><i>(1) Rights and interests of account holders of a relevant intermediary that have become effective against third parties under Article 11 and interests granted by such account holders that have become effective under Article 12 are effective against the insolvency administrator and creditors in any <u>insolvency proceeding</u> in relation to the relevant intermediary or in relation to any other person responsible for the performance of a function of the relevant intermediary under Article 7.</i></p> <p><i>(2) Paragraph 1 does not affect: (a) any rule of law applicable in the <u>insolvency proceeding</u> relating to the avoidance of a transaction as a preference or a transfer in fraud of creditors; or (b) any rule of procedure relating to the enforcement of rights to property that is under the control or supervision of the insolvency administrator.</i></p> <p><i>(3) Nothing in this Article impairs the effectiveness of an interest in intermediated securities against the insolvency administrator and creditors in any insolvency proceeding referred to in paragraph 1, if that interest has become effective by any method referred to in Article 13.</i></p>	<p>OFFICIAL COMMENTARY:</p> <p>Paras 21-10 to 21-14</p> <p>Legislative Guide:</p> <p>Paras 255 to 257</p>

<p>Article 26(1):</p> <p><i>This Article applies in any <u>insolvency proceeding</u> in relation to an intermediary unless otherwise provided by any conflicting rule applicable in that proceeding.</i></p>	<p>OFFICIAL COMMENTARY:</p> <p>Paras 26-1, 26-9</p> <p>Legislative Guide:</p> <p>Para 258</p>
<p>Article 27:</p> <p><i>To the extent permitted by the law governing a system, the following provisions shall have effect notwithstanding the commencement of an <u>insolvency proceeding</u> in relation to the operator of that system or any participant in that system and notwithstanding any invalidation, reversal or revocation that would otherwise occur under any rule applicable in an insolvency proceeding: (a) any provision of the uniform rules of a securities settlement system or of a securities clearing system in so far as that provision precludes the revocation of any instruction given by a participant in the system for making a disposition of intermediated securities, or for making a payment relating to an acquisition or disposition of intermediated securities, after the time at which that instruction is treated under the rules of the system as having been entered irrevocably into the system; (b) any provision of the uniform rules of a securities settlement system in so far as that provision precludes the invalidation or reversal of a debit or credit of securities to, or a designating entry or removal of a designating entry in, a securities account that forms part of the system after the time at which that debit, credit, designating entry or removal of a designating entry is treated under the rules of the system as not liable to be reversed.</i></p>	<p>OFFICIAL COMMENTARY:</p> <p>Paras 27-1 to 27-3, 27-19</p> <p>Legislative Guide:</p> <p>Para 223</p>

ANNEX 5

REFERENCES TO UNIFORM RULES OF SCSs AND SSSs

References in the Convention	For discussion
<p>Article 1(l):</p> <p><i>"designating entry" means an entry in a securities account made in favour of a person (including the relevant intermediary) other than the account holder in relation to intermediated securities, which, under the account agreement, a control agreement, the <u>uniform rules of a securities settlement system</u> or the non-Convention law, has either or both of the following effects:</i></p> <p>[...]</p> <p><i>(ii) that the relevant intermediary is obliged to comply with any instructions given by that person in relation to the intermediated securities as to which the entry is made in such circumstances and as to such matters as may be provided by the account agreement, a control agreement or the <u>uniform rules of a securities settlement system</u>, without any further consent of the account holder;</i></p>	<p>OFFICIAL COMMENTARY:</p> <p>Paras 1-50 to 1-54</p> <p>Legislative Guide:</p> <p>Paras 141 to 146</p>
<p>Article 1(n):</p> <p><i>"securities settlement system" means a system that: (i) settles, or clears and settles, securities transactions; (ii) is operated by a central bank or central banks or is subject to regulation, supervision or oversight by a governmental or public authority in relation to its rules; and (iii) has been identified as a securities settlement system in a declaration made by the Contracting State the law of which governs the system on the ground of the reduction of risk to the stability of the financial system;</i></p>	<p>OFFICIAL COMMENTARY:</p> <p>Paras 1-61 to 1-88</p> <p>Legislative Guide:</p> <p>Paras 70, 220 et seq.</p> <p>Declarations Memorandum:</p> <p>Section 4.A and accompanying Form No. 1</p>
<p>Article 1(o):</p> <p><i>"securities clearing system" means a system that: (i) clears, but does not settle, securities transactions through a central counterparty or otherwise; (ii) is operated by a central bank or central banks or is subject to regulation, supervision or oversight by a governmental or public authority in relation to its rules; and (iii) has been identified as a securities clearing system in a declaration made by the Contracting State the law of which governs the system on the ground of the reduction of risk to the stability of the financial system;</i></p>	<p>OFFICIAL COMMENTARY:</p> <p>Paras 1-89 to 1-99</p> <p>Legislative Guide:</p> <p>Paras 70, 220 et seq.</p> <p>Declarations Memorandum:</p> <p>Section 4.A and accompanying Form No. 1</p>
<p>Article 1(p):</p> <p><i>"uniform rules" means, in relation to a securities settlement system or securities clearing system, rules of that system (including system rules constituted by the non-Convention law) which are common to the participants or to a class of participants and are publicly accessible.</i></p>	<p>OFFICIAL COMMENTARY:</p> <p>Paras 1-100 to 1-107</p> <p>Legislative Guide:</p> <p>Para 75</p>
<p>Article 9(1)(c):</p> <p><i>The credit of securities to a securities account confers on the account holder: [...] (c) the right, by instructions to the relevant intermediary, to cause the securities to be held otherwise than through a securities account, to the extent permitted by the applicable law, the terms of the securities and, to the extent permitted by the non-Convention law, the account agreement or the <u>uniform rules of a securities settlement system</u>;</i></p>	<p>OFFICIAL COMMENTARY:</p> <p>Paras 9-24 to 9-26</p> <p>Legislative Guide:</p> <p>Paras 82, 236</p>

<p>Article 10(2)(c), (e) and (f):</p> <p><i>An intermediary must, at least: [...] (c) give effect to any instructions given by the account holder or other authorised person, as provided by the non-Convention law, the account agreement or the <u>uniform rules of a securities settlement system</u>; [...] (e) regularly pass on to account holders information relating to intermediated securities, including information necessary for account holders to exercise rights, if provided by the non-Convention law, the account agreement or the <u>uniform rules of a securities settlement system</u>; and (f) regularly pass on to account holders dividends and other distributions received in relation to intermediated securities, if provided by the non-Convention law, the account agreement or the <u>uniform rules of a securities settlement system</u>.</i></p>	<p>OFFICIAL COMMENTARY:</p> <p>Paras 10-13, 10-15 to 10-17</p> <p>Legislative Guide:</p> <p>Paras 100 to 119, 221</p>
<p>Article 15(2):</p> <p><i>The non-Convention law and, to the extent permitted by the non-Convention law, the account agreement or the <u>uniform rules of a securities settlement system</u> determine the consequences of: an unauthorised debit; an unauthorised removal of a designating entry; subject to Article 18(2), an unauthorised designating entry; or any other unauthorised disposition.</i></p>	<p>OFFICIAL COMMENTARY:</p> <p>Paras 15-18 to 15-19</p> <p>Legislative Guide:</p> <p>Paras 165 to 171</p>
<p>Article 16:</p> <p><i>Subject to Article 18, the non-Convention law and, to the extent permitted by the non-Convention law, the account agreement or the <u>uniform rules of a securities settlement system</u> determine whether and in what circumstances a debit, credit, designating entry or removal of a designating entry is invalid, is liable to be reversed or may be subject to a condition, and the consequences thereof.</i></p>	<p>OFFICIAL COMMENTARY:</p> <p>Para 16-1 and 16-22</p> <p>Legislative Guide:</p> <p>Paras 165 to 171</p>
<p>Article 18(5):</p> <p><i>To the extent permitted by the non-Convention law, paragraph 2 (which states that “[u]nless an acquirer actually knows or ought to know, at the relevant time, of an earlier defective entry: (a) the credit or interest is not rendered invalid, ineffective against third parties or liable to be reversed as a result of that defective entry; and (b) the acquirer is not liable to anyone who would benefit from the invalidity or reversal of that defective entry”) is subject to any provision of the <u>uniform rules of a securities settlement system</u> or of the account agreement.</i></p>	<p>OFFICIAL COMMENTARY:</p> <p>Paras 18-11 and 18-12</p> <p>Legislative Guide:</p> <p>Paras 172, 221</p>
<p>Article 23(2)(e):</p> <p><i>Paragraph 1 [which states that “[a]n intermediary is neither bound nor entitled to give effect to any instructions in relation to intermediated securities of an account holder given by any person other than that account holder”] is subject to [...] (e) if the intermediary is the operator of a securities settlement system, the <u>uniform rules of that system</u>.</i></p>	<p>OFFICIAL COMMENTARY:</p> <p>Para 23-28</p> <p>Legislative Guide:</p> <p>Para 221</p>
<p>Article 24(4):</p> <p><i>This Article does not affect any provision of the non-Convention law, or, to the extent permitted by the non-Convention law, any provision of the <u>uniform rules of a securities settlement system</u> or of the account agreement, relating to the method of complying with the requirements of this Article or the allocation of the cost of ensuring compliance with those requirements or otherwise relating to the consequences of failure to comply with those requirements.</i></p>	<p>OFFICIAL COMMENTARY:</p> <p>Para 24-22</p> <p>Legislative Guide:</p> <p>Para 218</p>
<p>Article 26(3):</p> <p><i>To the extent permitted by the non-Convention law, if the intermediary is the operator of a <u>securities settlement system and the uniform rules of the system</u> make provision in case of a shortfall, the shortfall shall be borne in the manner so provided.</i></p>	<p>OFFICIAL COMMENTARY:</p> <p>Para 26-12</p> <p>Legislative Guide:</p> <p>Para 221</p>

<p>Article 27:</p> <p><i>To the extent permitted by the law governing a system, the following provisions shall have effect notwithstanding the commencement of an insolvency proceeding in relation to the operator of that system or any participant in that system and notwithstanding any invalidation, reversal or revocation that would otherwise occur under any rule applicable in an insolvency proceeding:</i></p> <p><i>(a) any provision of the <u>uniform rules of a securities settlement system</u> or of a <u>securities clearing system</u> in so far as that provision precludes the revocation of any instruction given by a participant in the system for making a disposition of intermediated securities, or for making a payment relating to an acquisition or disposition of intermediated securities, after the time at which that instruction is treated under the rules of the system as having been entered irrevocably into the system;</i></p> <p><i>(b) any provision of the <u>uniform rules of a securities settlement system</u> in so far as that provision precludes the invalidation or reversal of a debit or credit of securities to, or a designating entry or removal of a designating entry in, a securities account that forms part of the system after the time at which that debit, credit, designating entry or removal of a designating entry is treated under the rules of the system as not liable to be reversed.</i></p>	<p>OFFICIAL COMMENTARY:</p> <p>Paras 27-1 to 27-8</p> <p>Legislative Guide:</p> <p>Para 223</p>
<p>Article 28(1), (2) and (3):</p> <p><i>(1) The obligations of an intermediary under this Convention, including the manner in which an intermediary complies with its obligations, may be specified by the non-Convention law and, to the extent permitted by the non-Convention law, the account agreement or the <u>uniform rules of a securities settlement system</u>.</i></p> <p><i>(2) If the substance of any such obligation is specified by the non-Convention law or, to the extent permitted by the non-Convention law, the account agreement or the <u>uniform rules of a securities settlement system</u>, compliance with it satisfies that obligation.</i></p> <p><i>(3) The liability of an intermediary in relation to its obligations is governed by the non-Convention law and, to the extent permitted by the non-Convention law, the account agreement or the <u>uniform rules of a securities settlement system</u>.</i></p>	<p>OFFICIAL COMMENTARY:</p> <p>Paras 28-1 to 28-3</p> <p>Legislative Guide:</p> <p>Paras 106 to 122, 221</p>