

COMMERCIAL IN CONFIDENCE

**AMENDED AND RESTATED CONTRACT FOR THE OPERATION OF THE
INTERNATIONAL REGISTRY FOR INTERNATIONAL INTERESTS IN
MOBILE EQUIPMENT
(RAILWAY ROLLING STOCK) (THE "IR")**

ATTACHMENT I

SERVICE LEVEL AGREEMENT (SLA)

1. Service Description

Introduction

This Service Description section of the SLA outlines the service which will be supplied.

Service Summary

The Contractor will operate the IR pursuant to the Convention, Protocol, Regulations and Procedures and using the best practices in current use in the field of electronic registry design and operation.

The IR will be available continuously through the Internet using standard technology and web browser software. An annual system availability of 100% will be achieved subject to the provisions of this SLA and the Regulations and Procedures.

Public Key Infrastructure technology will be utilised to provide data integrity and non repudiation.

The Contractor will provide technical support and business process support to users of the IR as described in this SLA.

The help desk is for technical and business support only and cannot provide support on other matters, including legal questions. The help desk cannot respond to queries concerning an administrator's, a registry user's or a searching person's:

- (a) computer or network system;
- (b) system security policies;
- (c) Internet access, including its connectivity and performance; or
- (d) browser.

The Contractor will provide feedback to the Supervisory Authority regarding industry needs and may propose changes to the Regulations and Procedures.

The Contractor will continuously develop system enhancements to meet the needs of the industry and to further improve the efficiency of the IR subject to the prior approval of the Supervisory Authority pursuant to the Change Control.

The Contractor will ensure that adequate security management and governance measures are in place.

COMMERCIAL IN CONFIDENCE

Governance

The Contractor will be governed under Luxembourg company law through its Board of Directors and will engage with industry through representative industry bodies and during conference events and seminars as well as through direct customer feedback.

The Contractor will undertake annual customer satisfaction surveys to ensure that it continues to meet the needs of the industry and to adjust its service offering in light of changing needs.

The Contractor will seek advice from the advisory board should one be established and industry feedback through, *inter alia*, the Rail Working Group (RWG).

The Contractor will comply with its duties under the applicable data protection legislation.

2. System Availability

The System Availability target is 100% except if precluded by maintenance performed outside peak periods, or technical or security problems.

Maintenance Window

Planned Maintenance will be carried out at times of low system usage. Low system usage will be determined through analysis of the web logs and is defined as times where system activity, measured in page downloads per second, is less than 20% of peak usage.

3. Support

Technical and Business Support

Provision of live help-desk services from 09:00 until 17:00 local time each local business day by email and phone as further specified in the Regulations.

Target response times

Target response and fix times will be achieved in more than 80% of cases raised excluding major system faults affecting all users, where all resources available to the Contractor will be deployed to resolve the issue as soon as is technically possible.

Account vetting and approval – 24 Hours (during Luxembourg office hours) from receipt of all documentation.
~~24 Hours (during Luxembourg office hours) from receipt of all documentation.~~

Priority	Response Time	Fix Time
High	4 hours	8 hours
Other	8 hours	24 hours

These fix times exclude cases where software development is required. High priority issues are issues which make registrations and searches unavailable for multiple customers.

COMMERCIAL IN CONFIDENCE

4. Reporting

The Contractor shall submit quarterly operational reports to the Supervisory Authority (within six (6) weeks of quarter end) indicating:

- 4.1 Accounting vetting –
 - 4.1.1 applications received;
 - 4.1.2 applications approved;
 - 4.1.3 applications declined; and
 - 4.1.4 decision times.
- 4.2 Technical support response and fix times summary.
- 4.3 Outages which occurred during the reporting period, planned and unplanned, along with a brief explanation.
- 4.4 List of official complaints received during the reporting period and the current status.

COMMERCIAL IN CONFIDENCE

ATTACHMENT II

DESIGN, IMPLEMENTATION, AND OPERATIONAL REQUIREMENTS

This note summarises the principal duties and obligations of the Registrar concerning the setting up and running of the International Registry.

1. The International Registry ("Registry") will facilitate the registration of, and searches against, international (security) interests, such as leases or asset pledges in relation to railway rolling stock as well as prospective international interests¹. It will design and implement the necessary electronic forms to collect the correct information for registration of international interests (and of prospective and fractional interests)² and assignments, subordinations, and subrogation thereof as well as searches against those interests. Similar facilities will be needed for the registration of, and search against, a notice of sale of individual items of railway rolling stock. Registrations of international interests entered into the International Registry data base must be searchable in chronological order of receipt, with the file recording the date and time of receipt. The Registry will also need to have a mechanism for notifying parties who have already registered international interests of any subsequent registrations on the same asset, for discharging international interests, registering pre-existing interests³ and national interests, correcting errors and facilitating user name changes.
2. Critically, the Registry will be able to register an international interest against a group of assets (for example, 1,000 wagons) with each asset having its own unique identification (URVIS⁴) number and allow searches against such groups, which would be separately identified with a special file number established by the Registry or the user. The Registry will provide for agreed (between the creditor and debtor) substitutions or modifications of the asset group.
3. A special process is required to register non-consensual rights and interests under Article 40 of the Convention, requiring the asset(s) concerned to be marked with URVIS numbering and to block, as far as reasonably determined, abuse.
4. Both the registrations and searches will be conducted seamlessly through the internet 24/7/365. Registrations and searches will be conducted through an online portal as well as mobile applications. The Registry and all data will be hosted in the cloud at data centres maintained and operated within the European Union under a separate contract with Microsoft Azure, AWS or another globally recognised and credible cloud service provider (the "Cloud Provider") and the data should be backed up in a different location (or region) separate to the source region for business continuity or disaster recovery. The Supervisory Authority will be notified as to the name of the Cloud Provider and be provided with a copy of the contract with the Cloud Provider, subject to the redaction of confidential and/or commercially sensitive terms. Additional functionality should be contemplated as the Registry evolves, for example, registering interests on assets through the use of QR codes or other form of asset authentication or validation codes.

¹ And searches against creditors and debtors but only with their consent.

² As required under section 5.3 of the Regulations. It will be important to include in the online form for registration the jurisdiction in which the debtor is located. This can, for example, be done by a drop-down menu. If the registration is by reference to the URVIS number, the form will need to include a provision whereby the registering party will confirm compliance with the UN ECE Model Rules on the Permanent Identification of Railway Rolling Stock

³ See Article 60 of the Convention as potentially modified by a declaration made pursuant to Article 60(3) as revised by Article XXVI of the Protocol.

⁴ See below.

COMMERCIAL IN CONFIDENCE

5. The Registry will need to provide priority search certificates showing the interests registered against a specific item of rolling stock either on demand or under a "standing order" system as well informational, contracting state and Registry user entity search certificates on demand, in each case against payment.
6. The Registry will provide a closing facility so that a succession of transactions can be closed and registered sequentially.
7. User access will be through a digitally secure multifactor authentication system with standard two factor (minimum) access system (similar to password and QR access systems used by banks) and not be dependent on pre-authorized computers. The Registry will provide a facility for individuals to create online accounts. Upon initial setup, individuals will be considered "unverified". Unverified users cannot perform registrations, only searches.
8. An individual can verify themselves by providing identifying information to the Registry. Upon verification, the user is considered "verified" and can now perform a registration on their own behalf. A verified user will also be able to designate alternates with full authority to make registrations (but not to appoint alternates) subject to ID verification by the Registrar⁵.
9. To operate on behalf of a legal entity, the verified user must submit a request to qualify and set-up such legal entity as a party qualified to make registrations in the Registry. This process must include evidence that the verified user has sufficient privileges to act on behalf of the entity.⁶ Once this process is completed, the verified user will be able to perform a registration on behalf of the legal entity. The verified user will also be able to manage access to the legal entity, i.e., add other verified users who can perform transactions on behalf of the legal entity.
10. Verified users will be able to set up their own pre-funded, privileged, direct access accounts with direct secure access to the Registry.
11. The Registrar will prepare official Procedures⁷ dealing with the logistics of its services, and terms and conditions for users, to be approved by the Supervisory Authority.
12. The Registry will publish and abide by the fee schedule for its services, as approved by the Supervisory Authority, but may introduce discounts and incentives as long as they are non-discriminatory.
13. The Registrar will set up, manage and maintain a secure (TLS1.2+ and proper SSL certificates and OWASP WCAG 2.1 or later guidelines) user-friendly applications and website available 24/7/365 with SLA as set out in Attachment I to Supervisory Contract using the Registry domain owned and made available by the Supervisory Authority and will upload official and other⁸ information to its website as directed by the Supervisory Authority.

⁵ The process will need to provide functionality to access hierarchical user access where a super user can assign different sets of roles to the other users (alternates) working for the super user.

⁶ The technical design should include a facility that allows the verified user to set up a group of qualified entities.

⁷ As authorised by the Regulations.

⁸ For example, declarations of compliance with the Model Rules on marking of rolling stock (and revocation of such declarations) with a link to the UNECE website.

COMMERCIAL IN CONFIDENCE

14. The Registry will utilise a third-party PCI⁹ compliant secure payment gateway which accepts credit card and other payment types for payment for services. The Registrar must not accept cash payments or payments in cryptocurrencies.
15. The Registry will also create a highly secure data storage system and secure digital access to the Registry for users.
16. The Registry will also facilitate secure direct access to the Registry from other national registries, through which registrations are to be made.
17. The Registry will store and automatically issue unique identification numbers (URVIS) for railway rolling stock and, if requested by a registered user, may also issue such numbers for a class of components¹⁰. This number will be 16 digits, including a check digit using the Luhn mod 10N algorithm (no leading zero). The Registrar may wish to facilitate requests for customised numbers.
18. The Registry will issue confirmations when relevant data about an entity (e.g. name) changes.
19. The Registry will monitor any glitches its procedures and equipment may produce, correct any resulting errors and issue corresponding notices to affected parties.
20. The Registry will provide some filings or contracts for information purposes, provided that these documents do not affect the rights of any person.
21. The Registry will provide a staffed helpdesk during European office hours, an FAQ page and a help feature on its website, including detailed instruction videos and manuals.
22. The Registry will complete and provide evidence of third-party Registry system testing (including user acceptance, functional, load and security testing), as well as run complete penetration testing by a recognised CREST approved penetration testing organisation in advance of go-live, along with documentation of Registry standards for records, data and operating procedures, which will be reviewed regularly and externally auditable, at the Registrar's cost, based on a schedule agreed with the Supervisory Authority.
23. On the Go-live date, the Registry must be GDPR compliant. Within a reasonable period of time in the context of industry standards and in alignment with the project implementation plan, the Registry will become compliant with ISO 27001 and other ISO and non-ISO standards considered appropriate by independent third party auditors, as agreed upon in advance by the Registrar and Supervisory Authority¹¹.
24. The Registry must maintain and make available on the Registry website a privacy policy detailing how personal data is collected and processed and for what purpose, as well as establish a system for opting into any website cookies and to deal with subject access requests.
25. The Registry will document a business continuity plan and a disaster recovery plan and will undertake annual business continuity and disaster recovery exercises. This will also be subject to an independent third party audit.

⁹ The Payment Card Industry Data Security Standard.

¹⁰ E.g. wheel sets or brakes.

¹¹ Names to be agreed in advance; auditor costs are for the Registrar.

COMMERCIAL IN CONFIDENCE

26. The Registry will be compliant with applicable international sanctions and EU rules on money laundering, bribery and corruption.
27. The Registry will need to manage and respond to a complaint process.
28. The Registry must maintain updated registration statistics and shall publish them in an annual report. This report shall be electronically accessible to any person.
29. Currently, the Registry will operate only in English but there could be the possibility of adding additional languages at a later date.
30. The Registry will operate under Regulations issued by the legal successor to the Preparatory Commission, the Supervisory Authority, that come into operation on the day the Protocol enters into force in contracting states.
31. The Registry will issue guidance notes from time to time concerning the implementation of the Regulations and Procedures affecting its operation. It will also need to make electronic copies of all of the aforementioned documents available to the public at no cost.
32. The Registrar and the Registry may offer ancillary services with the prior written consent of the Supervisory Authority.
33. The Registrar will maintain a regular dialogue with the Supervisory Authority, acting through the Secretariat (OTIF), and pay the Secretariat its pre-agreed fees.
34. The first Registrar, Regulis S.A. ("Regulis"), or companies within its group have detailed experience of running asset registries. To that end, Regulis may use proprietary software and/or open access software. It is a clear condition of its retainer that the Registrar holds all data concerning the security interests, the website and the Registry domain on behalf of the Supervisory Authority and may not use such data, website or domain other than for providing the Registry services except where authorised by the Supervisory Authority.
35. The Registrar will operate the Registry for a minimum term of ten (10) years. There must be a facility to upgrade storage and operational software as is usual in the industry.
36. All data on the Registry must be kept in a format that allows its unrestricted portability in a readable form using open source or generally available licensed software.

COMMERCIAL IN CONFIDENCE

**CONTRACT FOR THE OPERATION OF THE INTERNATIONAL REGISTRY FOR
INTERNATIONAL INTERESTS IN MOBILE EQUIPMENT
(RAILWAY ROLLING STOCK)**

ATTACHMENT II

SYSTEM DESIGN

~~1. Summary~~ **Appendix 1**

~~This document provides an indicative description of the IR's technical features. [All references to software versions shall be deemed to be modified to mean not earlier than the latest applicable version issued by the software supplier prior to the version current on the Go-Live Date.] For clarity these have been broken down into two sub-sections which are further elaborated by 2 (two) appendices. The sub-sections are a) Software Architecture Components, and b) Functionality of the IR system. These sub-sections refer to the more detailed appendices. The appendices are as follows:~~

~~Appendix 1 — High Level Design: This describes the indicative technical infrastructure at system launch. The initial technical infrastructure is designed taking account of the parties' wish to minimise cost. As capacity needs increase the technical infrastructure may be upgraded under the Commercial Change Control Process.~~

~~Appendix 2 — Baseline Regulations.~~

2. Software Architecture Components

Limitations

The software system and architecture will not include or support the following items:

- ~~1. — The entry of Authorising Entry Point Codes (AEP codes). Where users are required to obtain an AEP code they will do so and make a declaration on the IR web site that they have obtained the code and have met the requirements of the Entry Point. This is necessary to avoid data entry of the codes for each registration which would reduce greatly the benefits of block registration functionality.~~
- ~~2. — All browsers which support the following list of technologies will be supported by the system:~~
 - ~~2.1 — Java~~
 - ~~2.2 — Keystore~~
- ~~3. — The system will be tested against the latest version of MS Internet Explorer supporting the technologies noted above.~~

COMMERCIAL IN CONFIDENCE

4. ~~When necessary, support for Contracting State numbering formats will be handled through Change Control.~~
5. ~~On line help will be provided through the availability of documents for download from the web site such as the User Manual.~~
6. ~~Should fulfilment of recommendations from the independent audit of the software require greater than 5 days of software development the resourcing of additional software development will be handled through Change Control.~~
7. ~~Tracing of IP addresses and dynamic Internet addresses will be carried out by the use of standard network logging and monitoring technology e.g. Firewall, Server System logs and Oracle logging. Such records will not be directly linked to individual records in the database.~~

Commercial Off The Shelf (COTS) Software Components:

~~The general approach is to use COTS packages of the highest standard with a strong brand name, good credibility and with strong technical support available. This allows the Contractor to confirm that the quality of the system is to the highest standards and that there is a traceable organisation and product history which can support future evidentiary needs. Oracle was selected as the highest standard database technology and for that reason other COTS components available from Oracle were also selected. This gives a single strategic supplier which reduces the likelihood of compatibility issues; however, this also minimizes the options for lowering costs in this area. At the time of deployment the Contractor may elect to use an alternative provider of an equivalent standard.~~

Oracle

~~The database used on the IR is Oracle Standard Edition, Version 11g. The database contains tables such as the registration table and the entity table. The database is set up in high integrity mode such that a change to the database will not be made unless it occurs at two sites simultaneously.~~

Operating Systems and Java version

~~Sun Solaris Operating System, Version 10 (64 Bit) is used on all servers. The system has been developed using Java, Version 1.6.~~

VeriSign gateway

~~VeriSign provides a web service to which the bespoke application communicates to manage Digital Certificates. This facilitates the account set up and consent requirements of the Regulations.~~

Payment gateway

~~A payment gateway client provided by ATOS (Version 2.04) is installed to process all credit card payments to facilitate the requirements of the Fee Schedule (Appendix to the Procedures).
Email gateway~~

~~An e-mail gateway, Sendmail, Version 8.14.4, is used to send, but not to receive, emails to registry users to notify them of system events such as those stipulated in the Regulations.~~

COMMERCIAL IN CONFIDENCE

Bespoke Software Components

A bespoke application will be developed by Prime Subcontractor to meet the requirements of the Regulations. In simple terms, the bespoke application covers three main areas i) Applications, ii) Registrations, and iii) Searches, although there is much more functionality to the bespoke application to be described in the User Manual.

COMMERCIAL IN CONFIDENCE

Applications

A person may connect to the website and make an on line application to set up a registry user entity account and to be the administrator of that entity. During the application process data is gathered about the administrator and the registry user entity and, once confirmed by a registry official to the standard set out in the Regulations, the administrator and the registry user entity may be approved. Once approved, a digital certificate is issued to the administrator in question which allows them to be identified and to consent. An administrator may, *inter alia*, approve registry users and may authorise professional users to work on specific objects on behalf of the registry user entity.

Registrations

The IR system allows registry users to make, amend and discharge registrations as required by the Regulations. Each registration is consented to electronically and that consent or consents is/are stored along with the registration data in the registration table where its integrity is protected by a set of hash functions based on public key infrastructure technology.

Searches

A registry user may search the IR, based upon URVIS number, for registrations made against that object. The registry user must follow a work flow and then a priority search certificate (PSC) is issued. The User Manual provides more detail. The application stores and digitally signs all PSCs.

A registry user may also perform a Contracting State search for which a certificate is also issued, signed and stored. This certificate details, *inter alia*, the declarations made under the Convention and Protocol by States Parties.

Registry users may also perform other searches for the purpose of efficiently using the IR system, including searches for contact details of named parties and professional user entities.

Java Applet

A java applet is downloaded onto a registry user's PC. The applet manages the Java Key Store file which contains the registry user's private key and their digital certificate. It allows registry users to select which certificate they are using and allows them to download a new certificate upon renewal.

3. Functionality of the IR system

The functionality of the IR will be based upon the functionality of the International Aircraft Registry software at the Notification Date, such software will be based on the Regulations Draft First Edition. The IR allows approved registry users to register interests as contemplated by the Convention and Protocol. Furthermore, it allows anyone, whether approved or not, to search the IR to ascertain what interests have been registered against an object. It also allows anyone to generate a Contracting State search certificate as described in the "Searches" section above. All of this functionality is provided by the bespoke application developed by Prime Subcontractor as described in the Bespoke Software Components section above.

COMMERCIAL IN CONFIDENCE

**CONTRACT FOR THE OPERATION OF THE INTERNATIONAL REGISTRY FOR
INTERNATIONAL INTERESTS IN MOBILE EQUIPMENT
(RAILWAY ROLLING STOCK)**

ATTACHMENT II

Appendix 1 — High Level Design Document (HLD)

Solution for Railway Registry

Overview

This document describes the indicative high level design of the server solution that will support the operational requirements for the International Registry.

Data Centre Hosting

~~The~~ Data Centre configuration is as follows:

- ~~Two separate data centres will provide hosting for the Primary and Disaster Recovery infrastructures. The data centres will be provided by EBRC and will be located in Luxembourg.~~
- ~~Each data centre will provide a single, private rack with 2 kW of capacity and remote “Hands and Eyes” services.~~
- ~~The servers in each data centre will be provided with 10 Mb Internet access, and each location will be provided with 8 public IP addresses. For resilience purposes, each data centre will use a different ISP. The data centres will be connected via a 1 Gb interconnection with a standard SLA that includes 99.6% availability.~~

Primary Site Infrastructure

~~The~~ proposed Primary site infrastructure is as follows:

- ~~A single Check Point IP295 external firewall managed by a SMART 1 appliance.~~
- ~~A single Cisco ASA 5510 internal firewall.~~
- ~~Sun Fire X2270 M2 Web and Management servers.~~
- ~~Sun Fire X4170 M2 Application and Database servers.~~
- ~~A single Cisco 2911 router to provide secure inter-site connectivity~~
- ~~Cisco Catalyst 2960 switches at each tier.~~
- ~~A Quantum Scalar i40 tape library with a single LTO 4 tape drive.~~
- ~~An ETERNUS DX90 S2 iSCSI disk array with replication option.~~

~~The Sun servers will run the Solaris 10 operating environment and Solaris Containers will be used to isolate workloads and minimise software license requirements.~~

~~The servers will provide internal resilience features including disk mirroring via Solaris ZFS, redundant NICs via IPMP, and redundant fans and power, where available.~~

COMMERCIAL IN CONFIDENCE

Apache v2.0 (or later) will be used for the Web server and Apache Tomcat application server will be used to support the Rail Registry application.

Oracle Database Standard Edition One has been proposed to support the Rail Registry database, which provides substantial cost savings over Enterprise Edition. Replication of changes to the primary database storage to the second site will be provided by the ETERNUS disk array Advanced Copy Manager's Remote Copy license.

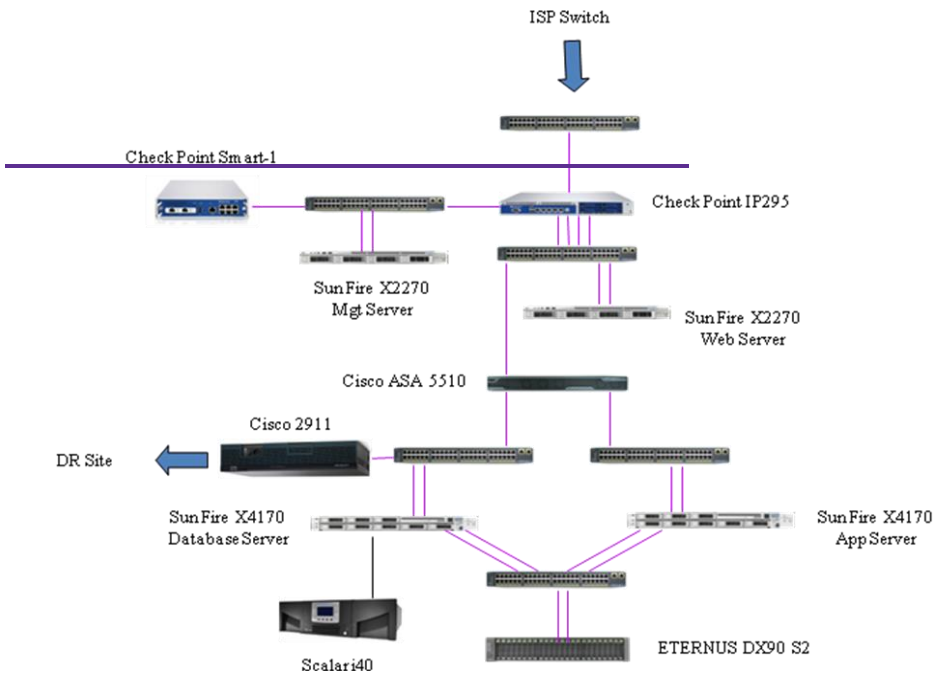

All servers and devices will log to a central Solaris container and Splunk will be employed to search, monitor and analyse log file data. Backups will be performed to the Quantum tape library under the control of NetBackup. All offsite database backups will be encrypted.

DR Site Infrastructure

The Disaster Recovery site infrastructure is the same as the Primary site. The DR site will host both Disaster Recovery and Pre-Production environments.

COMMERCIAL IN CONFIDENCE

**~~CONTRACT FOR THE OPERATION OF THE INTERNATIONAL REGISTRY FOR
INTERNATIONAL INTERESTS IN MOBILE EQUIPMENT
(RAILWAY ROLLING STOCK)~~**

~~ATTACHMENT II~~

Appendix 2 – Baseline Regulations



INTERNATIONAL INSTITUTE FOR THE UNIFICATION OF PRIVATE LAW
INSTITUT INTERNATIONAL POUR L'UNIFICATION DU DROIT PRIVE

OTIF



**ORGANISATION INTERGOUVERNEMENTALE POUR LES
TRANSPORTS INTERNATIONAUX FERROVIAIRES**

ZWISCHENSTAATLICHE ORGANISATION FÜR DEN
INTERNATIONALEN EISENBAHNVERKEHR

**INTERGOVERNMENTAL ORGANISATION FOR
INTERNATIONAL CARRIAGE BY RAIL**

Preparatory Commission regarding the
establishment of the International Registry for
railway rolling stock according to the
Luxembourg Protocol

DRAFT

REGULATIONS FOR THE INTERNATIONAL REGISTRY

COMMERCIAL IN CONFIDENCE

This is a working draft of regulations which would be issued in due course by the Supervisory Authority in accordance with Luxembourg Protocol to the Cape Town Convention.

Shortly before the Protocol is expected to come into force, the Preparatory Commission will issue a further consultation draft particularly reflecting the software and other operational aspects applicable to the International Registry as it comes into operation.

The Preparatory Commission also expects to issue a separate schedule of charges expected to apply to the services being provided by the International Registry.

COMMERCIAL IN CONFIDENCE

DRAFT

REGULATIONS FOR THE INTERNATIONAL REGISTRY

(Article 17(2) (d) of the Convention on international interests in mobile equipment and the Luxembourg Protocol)

CONTENTS

Section	1	AUTHORITY	11 <u>3</u>
Section	2	DEFINITIONS	11 <u>3</u>
Section	3	GENERAL PROVISIONS	13 <u>6</u>
Section	4	ACCESS TO THE INTERNATIONAL REGISTRY	14 <u>7</u>
Section	5	INFORMATION REQUIRED TO EFFECT REGISTRATION	15 <u>9</u>
Section	6	CONFIRMATION AND NOTICE OF REGISTRATION	20 <u>21</u>
Section	7	NON-CONVENTION FILINGS	21 <u>21</u>
Section	8	SEARCHES IN THE INTERNATIONAL REGISTRY	21 <u>21</u>
Section	9	OPERATIONAL COMPLAINTS	22 <u>24</u>
Section	10	CONFIDENTIALITY	23 <u>25</u>
Section	11	STATISTICS	23 <u>26</u>
Section	12	RELATIONS WITH ANNUAL REPORT TO THE SUPERVISORY AUTHORITY	23 <u>26</u>
Section	13	RELATIONS WITH THE <u>DESIGNATED</u> ENTRY POINTS	23 <u>26</u>
Section	14	FEES	24 <u>27</u>
Section	15	RELATIONSHIP WITH REGIONAL AND NATIONAL SYSTEMS	25 <u>28</u>
Section	16	LIABILITY AND INSURANCE OF THE REGISTRAR	25 <u>28</u>

COMMERCIAL IN CONFIDENCE

Section	17	INTERNATIONAL REGISTRY PROCEDURES	26 <u>29</u>
Section	18	PUBLICATION	262 <u>2</u>
Section	19	NOTIFICATIONS	263 <u>0</u>
Section	20	FINAL PROVISIONS	273 <u>0</u>
<u>Appendix</u>		<u>RAIL CLOSING FACILITY</u>	<u>31</u>

COMMERCIAL IN CONFIDENCE

Section 1 AUTHORITY

These Regulations are issued by the Supervisory Authority pursuant to Article 17(2)(d) of the *Convention on International Interests in Mobile Equipment* ("Convention") and are authorised by the *Luxembourg Protocol to the Convention on International Interests in Mobile Equipment on Matters specific to Railway Rolling Stock* ("Protocol").

Section 2 DEFINITIONS

~~2.1.20.1~~ Terms defined in the Convention and the Protocol shall have the same meanings in these Regulations. In addition, the following terms shall have the meanings set out below:

2.1.1. "Administrator" means the person with authority to act on behalf of a registry user entity on administrative matters in dealings with the Registrar and the International Registry, and ~~an "includes his/her acting administrator" to whom he/she has the meaning set out~~ delegated his/her powers in accordance with Section 4.1.

2.1.2. "Amendment"~~"~~, ~~unless the context suggests otherwise~~, means any change in ~~registration~~ registered information, including any change in the ~~duration~~ lapse date of a registration, but does not include assignment, subrogation or subordination.

2.1.3. "Authorization" means an electronic authorization given by the administrator of a transacting user entity to one of its transacting users or to a professional user to transmit information to the International Registry to effect or consent to a registration on behalf of that transacting user entity.

~~2.1.4. "Authorised Representative" means a person authorised to effect a registration of an international interest, prospective international interest, or assignment or prospective assignment of any of the foregoing in an agency, trust or other representative capacity.~~

~~2.1.5-2.1.4.~~ "Consent" means an electronic consent to a registration.

2.1.5. "Contact information" means, with respect to the entity or natural person to whom such information relates, such entity's or natural person's name, administrator and that administrator's telephone number and electronic address.

2.1.6. "Contracting State agreement" means an agreement between a Contracting State and the Supervisory Authority pursuant to, or in relation to implementation of Article XIII or Article XIV of the Protocol.

~~2.1.6-2.1.7.~~ "Controlled entity" means a business entity, trust or association of any kind, however established, with capacity to be a named party in registrations, where a transacting user entity electronically asserts that it controls, manages or administers that business entity, trust or association.

2.1.8. "Documentary evidence" means documentation that fully substantiates that an interest being registered is of a kind that has been conferred under the law of the Contracting State identified in the information to effect a registration, including evidentiary documentation issued by government entities.

COMMERCIAL IN CONFIDENCE

- 2.1.9. “Entry point” means an entity designated by a Contracting State as contemplated by Article XIII (1) of the Protocol through which information required for registration under the Convention and the Protocol shall or may be directly transmitted to the International Registry and an “entry point user” means an official, employee, member or partner of an entry point.
- 2.1.7-2.1.10. “Fee ~~Schedule~~ schedule” means a schedule issued by the Supervisory Authority in accordance with section 14.1 and which is in force at the relevant time.
- 2.1.8-2.1.11. “Identification data” means information required to effect a registration of an international interest in an item of rolling stock referred to in Section 5.3 (a) - (c).
- 2.1.9-2.1.12. ~~“Identity information” means the name, address and electronic address of following in respect of the entity or natural person in respect of for whom the identifying identity information is sought.~~
- (a) the name, principal physical address, and date of birth for a natural person;
- (b) the name, state of incorporation or formation, and principal physical business address for an entity; and
- (c) any other information reasonably required by the Registrar.
- 2.1.13. “Information” includes signatures, consents to registration, certifications and other documents.
- 2.1.10-2.1.14. ~~“Named party” means a party named as a party in a registration, and a “named representative” means a person the transacting user entity named in a registration and acting for others in an agency, trust or other representative capacity in accordance with Article IV of the Protocol.~~
- 2.1.15. “Non-Convention filing” means a notice of sale or a filing or contract information relating to an international interest approved under Section 7.1.
- 2.1.11-2.1.16. “Professional user entity” means a person, firm, limited liability partnership or corporation or other grouping of persons (such as an internal legal department of a transacting user entity) providing professional services to transacting user entities in connection with the transmission, to the International Registry, of information relating to registrations, and a “professional user” means an individual employee, member or partner of a professional user entity.
- 2.1.17. “Registered information” means the category of registration, together with the information entered in the International Registry to effect such registration pursuant to Sections 5.3 (b), (c), (d) and (g), 5.6 (a), (b) and (c), 5.7 (a), 5.8 (a), (c) and (d), 5.10 (d), 5.11 (a), (c), (d), (e) and (f), 5.13 (a), (c) and (d), 5.17, 5.18 (a) (ii), 5.20 (a), (c) and (d), and 5.23 (a) and (b) in each case as applicable to such category of registration, and shall include any correction or discharge of a registration pursuant to Section 5.21. The name and the electronic signature of the registering person, and the contact information of the persons to which the International Registry is required to send notices pursuant to Section 6, shall not be regarded as registered information. For purposes of a registration under Sections 5.6, 5.12, 5.22 and 5.23, the name of the registry user entity that effects the registration shall be regarded as registered information.
- 2.1.12-2.1.18. “Registration” means ~~an~~ registration of a right or interest or notice of sale electronically registered with the International Registry. For the purposes of Sections 4.3(e), ~~4.4~~, 5.24, 6 and 6.3.3, the term has the extended meaning set out in Section 6.1. A “registering person” means ~~a registry~~ the transacting user, professional user or an entity designated as an entry

COMMERCIAL IN CONFIDENCE

point user transmitting information to the International Registry to effect a registration ~~in accordance with Section 13 below.~~

~~2.1.13-2.1.19.~~ "Registry user entity" means:

- ~~(a)~~ (a) a transacting user entity; or
- ~~(b)~~ (b) a professional user entity; and
- ~~(c)~~ (c) an entry point.

~~A~~ "registry user" means a transacting user ~~or~~ a professional user or an entry point user.

~~A~~ "guest user" means a person having a guest user account who may search the International Registry, but not having the right to consent to a registration.

~~2.1.20.~~ "R-NCRI" means a registrable non-consensual right or interest in an item of railway rolling stock conferred under the law of the Contracting State in which the right or interest arose, as provided in Articles 1 (dd) and 40 of the Convention.

~~2.1.21.~~ "R-NCRI authorization" means a registrable non-consensual right or interest authorization that confers the authority to effect or amend the registration that is contemplated by Section 5.6.

~~2.1.14-2.1.22.~~ "Searching person" means a person making a search in accordance with Sections 7 or 8 of these Regulations.

~~2.1.23.~~ "Supplemental descriptor" means a numeric or alphanumeric descriptor specified by a registering person when making a registration of an international interest or a notice of sale and which shall include any information provided under Section 5.3 (c) (ii) and (iii) where conditions have not been fulfilled to enable the provision of such information to comply with the requirements therein to effect the registration of an international interest.

~~2.1.15-2.1.24.~~ "Transacting user entity" means a legal entity, natural person or more than one of the foregoing acting jointly intending to be a named party in one or more registrations, and a "transacting user" means an individual employee, member or partner of a transacting user entity or an affiliate of that entity.

~~2.1.25.~~ "Unilateral registration" means a registration pursuant to Section 5.6, 5.12, 5.22 or 5.23.

~~2.1.16-2.1.26.~~ "URVIS identifier" means, in respect of an item of railway rolling stock, the unique, ~~2016-~~ digit identification number allocated in accordance with the system prescribed by Section 5 ~~of these Regulations.~~

~~2.20.2~~ The term or terms:

~~"entry point", has the meaning set out in Section 13.1;~~

~~"International Registry Procedures" has the meaning set out in Section 17.1;~~

~~"priority search", "priority search certificate", "informational search listing", "Contracting State search" and, "Contracting State search certificate", "registry user entity search" and "self-search" and "supplementary priority search information" have the meanings set out in Section 8;~~

~~"group registration" and "group search" shall mean respectively a registration of international interests held by a creditor in a multiple number of items of railway rolling stock identified in accordance with Article XIV of the Protocol and a search at the International Registry against such multiple number of items.~~

COMMERCIAL IN CONFIDENCE

A “group identifier” has the meaning set out in Section 5.5.

2.3 For the purposes of these Regulations an “item of railway rolling stock” means a vehicle which:

(a) satisfies the definition of “railway rolling stock” in Article I-(2) (e) of the Protocol;

~~(b) is able to be operated with or without traction;~~

~~(c) may be physically separated, from other vehicles and may continue to be operated under normal industry conditions after such separation; and-~~

~~(d) may be operated alone or contiguous to various other vehicles, without the need for any special adaptation or use of additional special equipment.-~~

Where a vehicle is made up of a number of articulated sections which are physically fixed to each other, but it is possible to replace or substitute such sections in the normal course of maintenance operations, whether using specialist equipment or otherwise, each articulated section shall be regarded as an item of railway rolling stock.

~~In order to ensure consistent application of this Section 2.3, the Registrar shall publish from time to time as it considers appropriate, and with the consent of the Supervisory Authority, guidance notes as to what constitutes an item of railway rolling stock. Such notes may not be challenged in the absence of manifest error but may be superseded by notes issued subsequently by the Registrar with the consent of the Supervisory Authority.~~

Section 3 GENERAL PROVISIONS

3.1 The International Registry is established as the facility for effecting and searching registrations under the Convention and the Protocol.

3.2 Since the International Registry merely provides notice of registrations, the facts underlying any such registration or registered interest shall determine whether it falls within the scope of the Convention and the Protocol. ~~Without limiting the foregoing, registrations of pre-existing rights and interests or assignment thereof shall have no legal effect under the Convention and the Protocol, except where, by virtue of a declaration under Article 60 (3) of the Convention, registration thereof is required.~~ The contents of this Section 3.2 shall be prominently displayed by the International Registry as a general cautionary note on its website. Neither this Section, nor the technical function of the Registry, shall relieve any party making a registration that ought not to have been made or is incorrect, from liability under applicable law.

3.3 The International Registry shall be accessible 24 hours a day, 7 days a week, except if precluded by maintenance performed outside peak periods, or technical or security problems, as set out in the ~~International Registry~~ Procedures. The International Registry shall be available in English and such other languages as shall be agreed between the Registrar and the Supervisory Authority from time to time.

COMMERCIAL IN CONFIDENCE

- 3.4 The Registrar shall operate the International Registry and perform the functions assigned to it by the Convention, the Protocol, these Regulations and the ~~International Registry~~ Procedures and such other functions and duties assigned to it or permitted by the Supervisory Authority. The Registrar shall not undertake other operations or responsibilities nor permit other parties to have access to or use the facilities of the International Registry without the prior written consent of the Supervisory Authority.
- 3.5 Technical support shall be provided to registry users, searching persons and administrators by a help desk of the International Registry, which shall be available during the Registrar's normal business hours (or otherwise as may be agreed between the Supervisory Authority and the Registrar), via telephone and/or fax, and/or ~~electronic mail~~ email or otherwise, as set out in the ~~International Registry~~ Procedures.
- 3.6 The International Registry may be used for no other purpose than that set forth in Sections 3.1 and 3.2, unless approved in advance by the Supervisory Authority and subject to the terms of that approval.
- ~~3.7 Information obtained from or through the International Registry about an entity or natural person shall not be used for marketing or promotional purposes or other commercial purposes unrelated to the use of the International Registry.~~

Section 4 ACCESS TO THE INTERNATIONAL REGISTRY

- 4.1 No registry user, registry user entity or administrator of that entity shall have access to the International Registry unless that entity and administrator are first approved as such by the Registrar and are otherwise in compliance with these Regulations and the ~~International Registry~~ Procedures. For the purposes of the preceding sentence, such approval shall be given when the Registrar reasonably concludes: ~~without undertaking specific legal analysis:~~
- (a) that such entity and administrator are who they claim to be; and
 - (b) on the basis of information submitted, ~~and without undertaking specific legal analysis,~~ that the latter is entitled to act as administrator of the former, ~~in each case, following the standards and procedures set out in the International Registry Procedures.~~
- ~~in each case, following the standards and procedures set out in the Procedures. The foregoing approval requirement is not applicable to a searching person.~~
- ~~No administrator of a transacting user entity shall be entitled to register or amend the registration of an R-NCRI or issue an R-NCRI authorization unless that administrator is first approved by the Registrar for that purpose. Such approval shall be given when the Registrar reasonably concludes, without undertaking specific legal analysis, that the administrator has the authority from his/her transacting user entity to make the certification and agreement required by Sections 5.6 (d) and (f), respectively.~~

COMMERCIAL IN CONFIDENCE

An administrator may from time to time, for periods not exceeding three (3) months electronically delegate his/her powers to an “acting administrator” ~~from time to time for periods not to exceed three (3) months~~ meeting the requirements of the Procedures.

A requested change to the electronic contact details of an administrator or other registry user may be made after the Registrar reasonably concludes that such requested change is authentic.

4.2. No registry user shall have access to the International Registry unless that user is first electronically approved as such by the administrator of the subject registry user entity and is otherwise in compliance with these Regulations and the ~~International Registry Procedures-procedures~~. No approved registry user shall be entitled to transmit information to the International Registry to effect a registration unless that user has first received authorization to do so. For the purposes of the preceding sentence, such electronic approval and authorization may be given at the sole discretion of the relevant administrator and may be revoked by such administrator at any time; and may be renounced by the registry user at any time.

4.2.1 No guest user shall have access to the International Registry unless that user first provides a valid electronic address at which he/she may be contacted and which shall be automatically verified.

4.3. Notwithstanding ~~the preceding paragraphs~~ Section 4.1 and 4.2:

(a) the administrator of a transacting user entity approved by the Registrar may electronically approve a controlled entity as a transacting user entity ~~upon the payment to the Registrar of the fee provided for in the Fee Schedule for the purposes of being named in the registrations upon the payment of the fee set out in the fee schedule and confirmation by that administrator that such transacting user entity controls, manages or administers such controlled entity;~~ and

(b) ~~in upon such a case approval,~~ the rights, powers and obligations of the administrator of the approving transacting user entity and its transacting users, respectively, shall apply ~~equally to the approved transacting user controlled entity; and~~

~~(c) a registration or a transfer of a right to discharge is valid if it is effected by a natural person who has been given the power to do so by a registry user authorised to effect such registration or such transfer of the right to discharge.~~

(c) the International Registry may provide a facility whereby a controlled entity approved pursuant to Section 4.3 (a) may be converted into a transacting user entity upon compliance with Section 4.1, including the appointment and approval of an administrator and the payment of applicable fees pursuant to the Procedures. Upon completion of the actions set forth in Section 4.1 with respect to such controlled entity, including approval by the Registrar:

(i) such controlled entity shall cease to be a controlled entity and shall henceforth be a transacting user entity; and

COMMERCIAL IN CONFIDENCE

(ii) the administrator of such transacting user entity shall thereupon have all rights, powers and obligations under these Regulations including, but not limited to, the right to revoke all previously approved registry user authorizations; and

(d) the International Registry may provide a facility whereby the control of a controlled entity may be transferred from one transacting user entity to another transacting user entity. Upon acceptance of the transfer of a controlled entity, the controlled entity will cease to be controlled by its initial approving administrator and the rights, powers and obligations of the administrator of the accepting transacting user entity shall apply to the transferred controlled entity. The administrator of the accepting transacting user entity shall thereupon have all the rights, powers and obligations of an administrator under these Regulations, including, but not limited to, the right to revoke all previously approved registry user authorizations.

4.4. Subject to these Regulations and in accordance with the ~~International Registry~~ Procedures, a registration may only be effected, with an authorization, by a registering person on behalf of the transacting user entity, which is a named party required or permitted to effect that registration under Article 20 of the Convention. A registration or transfer of a right to consent to the discharge of a registration is valid if it is effected by a natural person who has been given the power to do so by a registry user authorized to effect such registration or such transfer of the right to consent to the discharge. The foregoing shall not apply in respect of a registration transmitted by an entry point, which shall be made in accordance with Section 13.3.

4.5. ~~No~~ A searching person and a guest user shall have access to the International Registry unless that person is first in compliance comply with these Regulations and the International Registry Procedures.

~~Section 5~~ Section 5 **INFORMATION REQUIRED TO EFFECT REGISTRATION**

Use of electronic information

5.1. In order to effect a registration, use of the URVIS identifier provided by the International Registry relating to railway rolling stock is mandatory and, where so provided, is the sole means of satisfying the requirements of Section 5.3 (c) ~~(i) and (ii).~~ For the purposes of the foregoing, "information provided by the International Registry" excludes information submitted in a different format by the registering person. To the extent such information is not so provided at the time the registration data are submitted to the International Registry, it shall be electronically entered by a registering person using the format prescribed in the ~~International Registry~~ Procedures, except as regards named parties (other than those whose consent is not required under ~~Sections~~ Section 5.7, 5.9 or 5.11) because they must be approved transacting user entities.

Complete identification

COMMERCIAL IN CONFIDENCE

- 5.2. Identity information shall be deemed complete only if ~~each~~all of the three elements contained in the definition of identity ~~is~~information are provided ~~and verified to the Registrar's satisfaction.~~

Registration of an international interest or a prospective international interest

- 5.3. The information required to effect the registration of an international interest, ~~a prospective international interest, a notice of a national interest~~ or a ~~registerable non-consensual right or prospective international interest,~~ is:
- (a) the ~~identity and digital~~electronic signature of the registering person ~~and a statement identifying on whose behalf that person is acting;~~
 - (b) the ~~identity~~name of each of the named parties, which in the case of the debtor shall include the state in which it is situated (in accordance with Article 4 of the Convention) both at the time the international interest is created and on the effective date of registration of the international interest;
 - (c) the following information identifying the item of railway rolling stock:
 - (i) the URVIS identifier allocated by the Registrar pursuant to Article XIV(1) of the Protocol; or
 - (ii) provided that the Registrar has agreed in advance that the name and identifier used are currently and prospectively unique and are compatible with the International Registry's systems, the manufacturer's name and ~~its unique~~the identifier affixed to the item associated with the URVIS identifier, if different to the URVIS identifier; ~~and/or~~
 - (iii) provided that an international interest is created or provided for, or is intended to be created or provided for, by an agreement entered into by a debtor situated in a Contracting State at the time of the conclusion of that agreement, the national or regional identification number assigned to the item under a national or regional system stated by a declaration made by ~~that~~that Contracting State according to Article XIV(2) of the Protocol, and agreed to by the Supervisory Authority under a Contracting State agreement, and affixed to the item associated with the URVIS identifier, if different to the URVIS identifier, and all of the national or regional identification numbers to which the item has been subject since the entry into force of the Protocol, and the time during which each number has applied to the item¹².
 - (d) the lapse date of the registration if the registration is to lapse prior to the filing of a discharge;
 - (e) ~~in the case of an international interest or a prospective international interest,~~ the consent of the named parties, given under an authorization; ~~and~~
 - (f) ~~the names and~~ electronic addresses of persons to which the ~~Registrar is required to~~International Registry shall send information notices pursuant to Section 6; and
 - (g) ~~if the named parties include more than one creditor, the name of the creditor who is to hold the sole right to consent to the discharge of that registration.~~

¹² The registry software will need to be able to identify and reject duplicates

COMMERCIAL IN CONFIDENCE

Where all of the information required in this Section 5.3 is not provided by the registry user entity at the time of the registration application, the Registrar shall not effect that registration. However nothing shall preclude ~~information being provided under subsection (e) (iii) if no declaration referred to therein is made.~~ (A) information being provided under subsection (c) (iii) in addition to information under subsection (c) (i) or (ii) even if no declaration referred to therein is made, or the relevant Contracting State agreement is not entered into, and if so provided the Registrar shall ensure that such information is recorded and is shown on a priority search certificate in respect of such item and (B) the registering person including one or more supplemental descriptors in accordance with the Procedures. The Registrar shall have no responsibility for the accuracy of any supplemental descriptor and the provision of one or more supplemental descriptors shall not require the Registrar to effect a registration.

The URVIS identifier shall be composed of ~~nineteen~~fifteen digits wholly numeric; zeroes shall be permitted in any position ~~and other than the first position and an~~ automatically generated check digit shall form the ~~twentieth~~sixteenth digit derived from the Luhn mod ~~N10N~~ algorithm. ~~Leading zeroes shall be inserted where appropriate and short gaps shall be left after the seventh and fourteenth digits.~~ The URVIS identifier shall be unstructured, i.e shall be allocated as determined by the Registrar subject to Section 5.4 below, save that it must incorporate all or part of national or regional identification numbers where relevant (that is, where a Contracting State has made a declaration pursuant to Article XIV(2) of the Protocol) in accordance with the terms of the agreement between the Contracting State and the Supervisory Authority. ~~Criteria for marking items of railway rolling stock with the URVIS identifier shall be set out in or adopted under the International Registry Procedures.~~

5.4. ~~The International Registry will allow a registry user to access the International Registry in order to obtain or reserve an URVIS number in accordance with the International Registry Procedures.~~ The International Registry may authorise a national or regional safety authority or agency or a party designated by such authority or agency, to issue URVIS numbers on behalf of the International Registry in accordance with the Procedures and any memorandum or agreement with such authority or agency.

~~5.5. The International Registry will provide a method or methods for group registrations and group searches, which may be further delineated as to type and other factors, consistent with filings and search solutions in the International Registry Procedures which accommodate current railway rolling stock financing practices. It will also allow for pre-requested searches and for the Registrar to issue to interested persons notifications of registration of a security interest registered subsequently to that registered by such interested persons.~~

~~Unless expressly permitted by the International Registry Procedures, free form data entry will not be permitted in the International Registry with regard to registration and searches of Convention interests that affect priority, perfection or enforcement or non Convention interests to be filed pursuant to Section 7.~~

~~5.5. The International Registry will provide a facility for registry users to establish, amend or delete groups of items of railway rolling stock ("group identifier") against which registrations may be effected and searches made.~~

COMMERCIAL IN CONFIDENCE

Unilateral Registration of an R-NCRI

5.6 The information required to effect the registration of ~~notices~~an R-NCRI to which Article 40 of the Convention applies is:

- (a) the identification data and the information referred to in Sections 5.3(d), (f) and (g), including, in the case of Section 5.3 (f), the electronic address of the primary obligor with respect to the obligation that is secured by the R-NCRI;
- (b) the name of the Contracting State under whose laws the R-NCRI has been conferred;
- (c) the category of R-NCRI, as listed in the declaration of the contracting state specified in Section 5.6 (b), within which the relevant R-NCRI being registered falls;
- (d) the certification of the party named in the registration as the holder of the R-NCRI to which the registration relates, that (i) the R-NCRI has been validly conferred under the laws of the Contracting State specified in Section 5.6 (b), and (ii) all of the registration information being provided to effect the registration is accurate;
- (e) documentary evidence pertaining to the R-NCRI submitted in electronic format; and
- (f) the agreement of the party named in the registration as the holder of that R-NCRI that by effecting such registration it submits itself to the jurisdiction of the courts of the place in which the Registrar has its centre of administration in relation to legal action under Article 44 of the Convention with regard to the registration, and that it shall be liable to the Registrar for all costs incurred by the Registrar arising out of the legal action unless the validity of the registration is upheld.

The registering person of an R-NCRI must either hold, or be the administrator that is entitled to issue, an R-NCRI authorization.

5.6.1 The Registrar shall provide a copy of the documentary evidence submitted in connection with the registration of an R-NCRI as regards an item of railway rolling stock to any of the following upon request:

- (a) the primary obligor identified in that registration;
- (b) the holder of any other registered right or interest relating to that an item of railway rolling stock or
- (c) any other person or entity that substantiates a potential adverse effect as a result of that registration to the reasonable satisfaction of the Registrar.

The foregoing shall not apply to the extent, in the Registrar's view, such provision of documentary evidence is prevented by applicable law.

Registration of a notice of sale and prospective

~~5.6.~~ 5.7 The information required to effect the registration of notices of sale, which shall be subject to Article XVII of the Protocol, is:

- ~~(a)~~ the identification data and the information referred to in Section 5.3 (f)
- ~~(b)~~(a) the consent of the named parties, given under an authorization; and
- ~~(c)~~ in the case of a prospective sale, the duration of the registration, if that registration is to lapse prior to the time of discharge.

COMMERCIAL IN CONFIDENCE

(b) the consent of the named parties, given under an authorization.

Registration of an assignment

~~5-7-5.8.~~ The information required to effect the registration of the assignment of an international interest, the prospective assignment of an international interest, the assignment of a ~~registerable non-consensual interest or an international interest acquired through subrogation is:~~ an R-NCRI is:

- (a) the identification data; and the information referred to in Section 5.3 (f) and (g);
- (b) the consent of the named parties, given under an authorization ~~except for that of the assignor in the case of an absolute assignment or where it is otherwise agreed between the assignor and assignee that only the assignee's consent is required;~~
- (c) if the interest being assigned is a registered interest,
 - ~~(e)(i)~~ the file number of the registration (if any) and any other registered identifier relating to that interest; (in the case of the initial assignment); or
 - (ii) the file number of the registered assignment by which the assignor acquired its rights in that registered interest (in the case of all subsequent assignments); and
- (d) if the interest being assigned is not a registered interest,
 - ~~(d)(i)~~ a description of the interest assigned and the original debtor thereunder, using the format prescribed by the International Registry Procedures; Procedures (in the case of the initial assignment of an unregistered interest); and
 - ~~(e)(ii)~~ in the case of an international interest acquired through subrogation, the file number of the registration of registered assignment by which the assignor acquired its rights in that interest; registered interest (in the case of all subsequent assignments).

Registration of a block assignment

~~5-8-5.9.~~ The International Registry may provide a facility permitting the registration of all assignments included in a "block assignment registration request". A "block assignment registration request" shall include:

~~(d)(a)~~ an electronic certification by the assignor that all of the underlying interests evidenced by registrations on the International Registry in which it is a named party have been assigned to the assignee, and

~~(e)(b)~~ a consent thereto given by the assignee,

each given under an authorization.

Discharge of a registration

~~5-9-5.10.~~ The information required to discharge a registration is:

~~(a)~~ the identification data;

COMMERCIAL IN CONFIDENCE

~~(b) the identity of the creditor, or holder of a national interest or registerable non-consensual right or interest, as the case may be;~~

(a) the information referred to in Sections 5.3 (a) and (f);

~~(e)(b)~~ except as provided in ~~Sections 5.9(d) and Section 5.910.1~~, the consent of the named party or parties benefiting from the registered interest or the party holding the right to consent to the discharge of such interest, given under an authorization;

~~(d)(c)~~ where a right ~~of~~ to consent to discharge a registration has been transferred, the consent of the party having this right;

~~(e)(d)~~ the file number of the registration to be discharged; and

~~(f)(e)~~ the date the discharge is to be effective.

~~5.9.4~~5.10.1 The party or parties mentioned in Sections 5.9~~(e)10 (b)~~ and ~~(d)c~~ do not include the debtor, assignor, subrogor or person subordinating the registered interest.

~~5.9.2~~ A5.10.2 The party or parties referred to in Section 5.9~~(e)10 (b)~~ may electronically transfer to a registry user entity, with the consent of that entity, the sole right to consent to the discharge of such registration. ~~Such sole right to consent to the discharge may be further transferred by a holder thereof to another registry user entity with the consent of the latter.~~

~~5.9.3~~5.10.3 The party or parties benefiting from a registration, the party holding the right to consent to the discharge of a registration under Section 5.3 (g) or, if such right has been transferred, the transferee of such right, shall have the sole right to consent to the discharge of that registration.

Registration of a subordination

~~5.10.5.11.~~ The information required to effect the registration of a subordination of an international interest, an assignment and prospective assignment of an international interest, a prospective international interest, a national interest ~~or a registerable non-consensual interest is: an interest acquired by subrogation or an R-NCRI, the interest of a lessee under a lease, or the interest of a buyer under a conditional sale is:~~

(a) the identification data and information referred to in Section 5.7~~(e)3 (f) and (g)~~, and for the purposes of the foregoing reference to Section 5.3 (b) and for the purposes of Section 5.4~~11~~ (b), the “named parties” shall be the registry user entities subordinating their interest and benefiting from that subordination;

(b) the consent of the named party whose interest is being subordinated, given under an authorization;

(c) the file number of the registration of the interest benefiting from the subordination;

(d) if the interest being subordinated or benefiting from the subordination is a registered interest, the URVIS identifier relating to each such interest; ~~and~~

(e) if the interest being subordinated or benefiting from the subordination is a registered interest that has been assigned, the file number of the registered assignment by which the party granting the subordination acquired its rights in that

COMMERCIAL IN CONFIDENCE

registered interest and, if applicable, the file number of the registered assignment by which the party benefiting from the subordination acquired its rights in the interest benefiting from the subordination;

(f) if the interest being subordinated or benefiting from the subordination is a registered interest that was acquired by subrogation, the file number of the registered subrogation by which the party granting the subordination acquired its rights in that registered interest and, if applicable, the file number of the registered subrogation by which the party benefiting from the subordination acquired its rights in the interest benefiting from the subordination; and

~~(e)~~(g) if the interest being subordinated or benefiting from the subordination is not a registered interest, a description of such interest and the original debtor thereunder, using the format prescribed by the International Registry Procedures.

~~Notwithstanding Sections 5.3 (e) and 5.7 (b), the~~Unilateral registration of a pre-existing right or interest

~~5.12.~~ The information needed~~required~~ to effect the registration of a pre-existing right or interest ~~required by virtue of a declaration under to which~~ Article 60 ~~(3)~~ of the Convention (as amended by Article XXVI of the Protocol) ~~need not include the consent~~ applies is:

(a) the identification data and the information referred to in Sections 5.3(d), (f) and (g);

~~5.11.(b)~~the name of the debtor, assignor or person subordinating the Contracting State under whose laws the pre-existing right or interest was constituted; and

(c) the certification of the party named in that registration as the holder of the pre-existing right or interest to which the registration relates, that (i) the pre-existing right or interest has been validly conferred under the laws of the Contracting State specified in Section 5.12 (b), and (ii) all of the registration information being provided to effect the registration is accurate and complete.

Amending a registration

~~5.12-5.13.~~ 5.13. Subject to Section 5.4~~3~~15, the information required to amend a registration (other than a registration of an R-NCRI) or to amend information contained in an assignment, subrogation or subordination is:

- (a) the identification data and information referred to in Section 5.3 (f);
- (b) the consent of the named parties that consented to the registration to be amended and, where a right of consent to discharge a registration has been transferred, the consent of the party having this right in place of the immediate transferor;
- (c) the file number of the registration to be amended; and
- (d) the amendments to be made.

Amending a registration of an R-NCRI

5.14. Subject to Section 5.15, the information required to amend a registration of an R-NCRI is:

- (a) the information referred to in Section 5.6 (a);

COMMERCIAL IN CONFIDENCE

- (b) the file number of the registration to be amended;
- (c) the amendments to be made; and
- (d) the certification required by Section 5.6 (d).

The registering person of an amendment of an R-NCRI registration must either hold, or be the administrator that is entitled to issue, an R-NCRI authorization.

Rules for amendments

~~5.13~~5.15. The following shall apply in respect of amendments to and discharges of amendments to registrations:

- (a) ~~Registration~~registration of an amendment of the identification data referred to in Section 5.3 (c) or a change of a category of registration shall be treated as a new registration in respect of the object or category to which the amending registration refers, with priority ranking from the time the amending registration is ~~complete~~searchable save that this shall not apply if the only amendment is to the data provided pursuant to Section 5.3(c) ~~(ii) or 5.3(c)~~ (iii) if the URVIS identifier remains unchanged. The named parties to such amendment shall consent to the discharge of the previous registration under an authorization, which shall be effected automatically~~;~~.
- (b) ~~Registration~~registration of an amendment in which the information referred to in Section 5.3 (b) has been changed shall require the consent of the named parties that consented to that registration and of the named party to be specified in the amended registration, each given under an authorization save that a name change notification request as described in ~~section 5.17~~Section 5.17~~18~~ shall not require such consent~~;~~.
- (c) ~~Registration~~registration of an amendment in which the information referred to in Section 5.3 (d) has been changed shall have no effect on the priority of the original registration for the amended duration of that registration. The foregoing is without prejudice as to whether a new underlying interest has been constituted that requires registration under the Convention~~;~~.
- (d) ~~A~~a change to a user capacity statement or the contact details of a registry user are outside of Section 5.13, and may be made after the Registrar reasonably concludes that such requested change is accurate~~;~~.
- ~~(e) When~~(e) when a registration is discharged, the party consenting to that discharge shall be deemed to consent to the discharge of all amendments to that registration, which shall be effected automatically.

~~—The consent requirements of Sections 5.15 (a) and (b) shall, in the case of an amendment of a registration of an R-NCRI, be limited to the party named in the registration as the holder of such R-NCRI.~~

~~5.14~~5.16. The consent requirements of this Section 5 shall be satisfied in the case of a registration initiated by an entry point in accordance with Article XIII (1) of the Protocol, when the International Registry receives the consent from all parties whose consent is required under the Convention, the Protocol, and these Regulations.

~~5.15~~5.17. Any registration may specify that multiple named parties hold or have granted an interest evidenced thereby.

COMMERCIAL IN CONFIDENCE

~~Registering fractional or partial interests~~

5.18. Any registration may specify that:

- (a) it covers a fractional or partial interest in an item of railway rolling stock and, if so, the extent of such interest; and/or
- (b) multiple named parties hold or have granted an interest evidenced thereby.

Rules for fractional or partial interests

~~5.16-5.19.~~ With respect to an interest referred to in Section 5.45:18 (a):

- ~~(a)~~ (a) an increase or decrease to such interest arising by virtue of a sale or an assignment of an international interest shall be registered as such in accordance with Sections 5.5 or Section 5.7, respectively; and
- ~~(b)~~ (b) a decrease in such an interest arising by virtue of payment of a secured obligation shall be partially or wholly discharged in accordance with Section 5.9; and 10.
- ~~(c)~~ an amendment changing such interest shall be permitted to correct an error when made in accordance with Section 5.12.

~~Entity name change~~

~~5.17-5.20.~~ The International Registry will provide a facility for notice of a change of the name of a registry user entity, where set out in a “name change notification request”. For purposes of the foregoing, a “change of name” means either that the registry user entity has changed its name, that any rights and interests of the registered interest has transacting user entity reflected on the International Registry have become vested in another transacting user entity as a new entity created by result of a merger, a change in entity form or otherwise by operation of law, or that a correction is required due to an error in theits name.- In such a case:

- (a) the information required to submit a name change notification to the International Registry is:
 - (i) the name currently shown on the International Registry for the entity which is to be changed, and its other identity information;
 - (ii) the name which is to supersede the name being changed, and in any case where rights and interests reflected on the International Registry have vested in a different transacting user entity, the corresponding entity’s other identity information and contact information; and
 - (iii) the name and electronic signature of the relevant transacting user entity and a statement on whose behalf that person is acting, and in any case where rights and interests reflected on the International Registry have vested in a different transacting user entity:
 - (A) the name and electronic signature of such other transacting user entity and a statement on whose behalf that person is acting; and
 - (B) the election specified in Section 5.20 (c) (ii) (B);
- ~~(a)~~ (b) the Registrar shall confirm that a name change notification request satisfies the requirements of this Section 5.20 following the standard set out in Section 4.1, and a name change shall take effect on the later of such confirmation by the Registrar and

COMMERCIAL IN CONFIDENCE

completion of the actions required in Section 5.20 (a) (iii); such changed name has been effected following the standard set out in Section 4.1;

- (c) ~~when so confirmed,~~ a name change takes effect:
- ~~(b)(i)~~ all registrations, rights and interests reflected on the International Registry in which that registry the transacting user entity specified in Section 5.20 (a) (i) is a named party shall, without amending registration, registered information or registering an assignment of such rights and interests, be annotated to advise of the change of name, such annotation to be included in all priority search certificates;
- (ii) following the time at in any case where rights and interests reflected on the International Registry have vested in a different transacting user entity:
- ~~(e)(A)~~ the transacting user entity in which such annotation is made, the renamed or resulting entity shall be deemed to be a registry rights and interests have vested shall retain its status as a transacting user entity for all the purposes of the International Registry; and all authorizations given or held by or on behalf of such transacting user entity shall remain in full force and effect; and
- ~~the vesting (B)~~ all authorizations given or held by or on behalf of the transacting user entity specified in Section 5.20 (a) (i) shall either remain in full force and effect or shall be extinguished, as elected by such transacting user entity; and
- (d) a name change shall have no effect on the validity or priority of the original any registration, or other rights or interests.

The International Registry may provide a corresponding facility for notice of a change of name to a professional user entity and for notice of a name change to a controlled entity.

Correcting an error of the International Registry system

5.4821 The Registrar ~~shall may~~ correct an error in ~~the International Registry created by a malfunction in the International Registry or discharge a registration or a discharge or the chronological order of registrations, or discharge a registration, if such error has been created by a malfunction in the International Registry, provided that such correction or discharge:~~

- ~~(a)~~ shall be effective only from the time it is made and shall have no effect on the priority of any other registration, and.
- ~~(b)~~ If such correction or discharge would change the registered information which would otherwise appear on a priority search certificate, notice that such correction or discharge has been made by the Registrar shall appear on all priority search certificates relating to the subject railway rolling stock.

The Registrar shall promptly give notice of any such correction or discharge to the named parties in the original registration and, if different, the parties making that registration, other parties with registered interests in that item of railway rolling stock, and those who have conducted a priority search on that item of railway rolling stock since the time of the original registration.

COMMERCIAL IN CONFIDENCE

Alternatively, the Registrar may request the named parties to the original registration to amend or discharge that registration, leave that registration in place as registered, or without limiting ~~Sections this Section 5.18 (a) or (b)~~²¹ seek an order from a court with jurisdiction under Article 44 (1) of the Convention.

Unilateral Registration of a subrogation

5.22 The information required to effect the registration of the acquisition of an international interest through subrogation is:

- (a) the identification data and the information referred to in Section 5.3 (f);
- (b) the consent only of the subrogee, given under an authorization;
- (c) if the interest being acquired by subrogation is a registered interest, the file number of the registration relating to that interest (in the case of the initial acquisition by subrogation of a registered interest), or if such interest has been assigned, the file number relating to such assignment; and
- (d) if the interest being acquired by subrogation is not a registered interest, a description of the interest acquired by subrogation and the original debtor thereunder, using the format prescribed by the Procedures, or if such interest has been assigned, the file number relating to such assignment.

Unilateral registration of a notice of a national interest

5.23 The information required to effect the registration of a notice of a national interest to which Article 50 of the Convention applies is:

- (a) the identification data and the information referred to in Section 5.3 (d), (f) and (g);
- (b) the consent of the holder of the national interest given under an authorization;
- (c) the name of the Contracting State under whose laws the national interest was constituted;
- (d) the certification of the party named in the registration as the holder of the national interest to which the registration relates, that (i) the national interest has been validly conferred under the laws of the Contracting State specified in Section 5.23 (b), and (ii) all of the registration information being provided to effect the registration is accurate and complete; and
- (e) documentary evidence pertaining to the national registration of the interest in electronic format.

5.23.1 The Registrar shall provide a copy of the documentary evidence submitted in connection with the registration of a notice of a national interest as regards an object to any of the following upon request:

- (a) the debtor identified in that registration;
- (b) the holder of any other registered right or interest relating to that object; or
- (c) any other person or entity that substantiates a potential adverse effect as a result of that registration to the reasonable satisfaction of the Registrar.

The foregoing shall not apply to the extent, in the Registrar's view, such provision of documentary evidence is prevented by applicable law.

Rail Closing facility

COMMERCIAL IN CONFIDENCE

- 5.24 The International Registry may provide a closing facility (“closing facility”) on its website permitting registry users to assemble the information required to effect a registration in advance of completing such registration and, in the case of multiple registrations in respect of one or more items of railway rolling stock, to establish the chronological order of such registrations. The Appendix to these Regulations describes the closing facility, including the conditions and procedures for:
- (a) assembling information prior to any registration taking effect;
 - (b) entering registrations into the International Registry data base containing such information; and
 - (c) making such registrations searchable, and establishing the order, date and time of receipt of such registrations by the International Registry;
- and in the cases of (b) and (c) above, for the purposes of Articles 18 (4) and 19 of the Convention.

Section 6 CONFIRMATION AND NOTICE OF REGISTRATION

- 6.1 In this Section, the term "registration" includes, where appropriate, an amendment, extension, or discharge of a registration—or transfer of the right to apply for, or consent to, the discharge of a registration.
- 6.2 ~~The Registrar~~International Registry shall ~~provide~~send prompt electronic confirmation of a registration to the named parties, the registering person and all other ~~interested persons. A confirmation shall contain the information set forth in Article 22 (2) (a) of the Convention~~persons entitled to receive notice of that registration under Section 5. The receipt or non-receipt of such confirmation does not imply that the registration has or has not been effected, that fact being determinable solely by means of a priority search.
- 6.3 ~~When a registration is effected relating to an item of railway rolling stock, an electronic notice thereof shall be sent to the named parties and registering persons~~in person of any other registration which has not been discharged relating to that item.
- 6.4 ~~The confirmation and notice referred to in Sections 6.2 and 6.3, respectively, shall include the registered~~ information specified in Section 5 relating thereto and the file number of the registration.
- 6.5 ~~Named parties may electronically elect not to receive the notices referred to in Section 6.3. Such elections shall require digital signatures. Registry users may request not to receive electronic notices in respect of one or more registrations~~items of railway rolling stock.

COMMERCIAL IN CONFIDENCE

Section 7 NON-CONVENTION FILINGS

7.1 To the extent approved by the Supervisory Authority, the Registrar shall provide for filings of other interests in railway rolling stock or contract information relating to international interests that are for the purposes of information only and do not affect the rights of any person, or have any other effect, under the Convention or this Protocol.

7.2 ~~Such~~ Non-Convention filings shall be subject to search as a priority search but the Registrar shall bear no responsibility or liability for any errors or omissions, and search results whether or not effective shall not affect perfection, priority or other rights or obligations under the Convention or the Protocol.

~~7.3 The provisions of Sections 5.13, 5.15 and 5.21 shall apply equally to non-Convention filings.~~

Section 8 SEARCHES IN THE INTERNATIONAL REGISTRY

8.1 A search of the International Registry as provided by Article 22 of the Convention in respect of an item of railway rolling stock shall be made by electronic means using one or more of the following criteria:

- (a) the URVIS identifier allocated to the item by the Registrar pursuant to Article XIV (1) of the Protocol; or
- ~~(b) [the manufacturer's unique identifier] (if this differs from the URVIS identifier allocated pursuant to Section 8.1 (a) above) or the number assigned to the item under a national or regional identification system where a declaration is made by a Contracting State according to Article XIV(2) of the Protocol; and~~
- ~~(c) the Registrar's group file number in relation to a group registration.~~

(b) the group identifier

Such search may be by means of a priority search ~~or informational search~~, as set out in ~~Sections~~Section 8.2 and 8.3, respectively. A Contracting State search and a registered user entity search may also be made, as set out in Section 8.5- and 8.6, respectively. A self-search may be made, as set out in Section 8.7. A search, other than a self-search pursuant to Section 8.7, may be performed by any person who complies with the ~~International Registry~~ Procedures, whether or not that searching person has a specific interest. A self-search of a particular transacting user entity (including any of its controlled entities) may be performed only by the administrator or replacement administrator of the entity in question where that administrator or replacement administrator complies with the Procedures. All searches shall be performed by electronic means.

The Registrar shall not permit searches other than by reference to the criteria stated above except where this has been approved by the Supervisory Authority.

COMMERCIAL IN CONFIDENCE

- 8.2 A “priority search” is a search for ~~registration~~registered information using one of the criteria specified in Section 8.1 ~~(a), (b) and, if appropriate (c).~~ Such information is searchable for the purposes of Articles 19 (2) and 19 (6) of the Convention and Article XV (1) of the Protocol.
- 8.3 An “informational search” is a search other than a priority search, using the ~~criteria specified in Section 8.1 (b), either alone or with another criterion set out in that Section. Such informational searches may include the use of symbols specified in the International Registry designed to produce inclusive search results.~~Section 5.3 (c) (ii) and (iii). The results of an informational search, an “informational search listing,” shall be a list of all matching items of railway rolling stock, described by the ~~items~~item set out in Section ~~8.1(a) to 5.3 (c) (ii) or (iii).~~ The facility to perform such an informational search does not make that information “searchable” for the purposes of Articles 19 (2) and 19 (6) of the Convention and Article XV (1) of the Protocol.

COMMERCIAL IN CONFIDENCE

- 8.4 A “priority search certificate” is a certificate issued in response to a priority search. It shall:
- (a) set out the registered information required or permitted by Article 22 (2) (a) or (b) of the Convention, as applicable Section 5, and comply with Article 22 (3) of the Convention;
 - (b) ~~if in the case where~~ Article 22 ~~(2)(a)~~ of the Convention applies, list the registered information in both
 - (i) chronological order and
 - (ii) a manner which indicates the transactional history of each registered interest; ~~and~~
 - (c) indicate the current holder of the right to consent to the discharge of a registration and set out in chronological order when that right ~~to discharge~~ has been transferred and the parties executing such transfer; ~~;~~
 - ~~(d) indicate the current holder of the right to discharge a registration and set out in chronological order when that right to discharge has been transferred and the parties executing such transfer; and~~
 - ~~(e) set out the electronic address of each of the named parties to the registration and of the current holder of the right to consent to the discharge of such registration, such addresses in each case to be based upon the most current contact information provided to the International Registry.~~

- 8.5 A “Contracting State search” is a search for all Contracting State agreements, declarations and designations, and withdrawals thereof, made under the Convention and the Protocol by the Contracting State specified in the search. A “Contracting State search certificate” is a certificate issued in response to a Contracting State search. A Contracting State search certificate shall:
- (a) indicate, in chronological order, all declarations and designations, and withdrawals thereof, by the specified Contracting State;
 - ~~(b)~~ show the date and effective date of any Contracting State agreements with the specified Contracting State and the date of any amendments thereto or termination thereof;
 - ~~(b)(c)~~ list the effective date of ratification, acceptance, approval or accession of the Convention and the Protocol, and of each declaration or designation, and withdrawal thereof, by the specified Contracting State; and
 - ~~(e)(d)~~ attach, in the electronic form set out in the International Registry Procedures, ~~(i)~~ copies of agreements referred to in Section 8.5 (b) and (ii) a copy of all instruments deposited by the specified Contracting State relating to items within the scope of Section 8.5 ~~(b)(c)~~.

~~Each priority~~ 8.6 A “registry user entity search” is a search for the registry user identity information and contact information (subject to such exclusions that the registry user entity has selected pursuant to Section 4.1). When conducted by a registry user, the search result shall indicate whether or not such registry user entity’s account is active. For the purposes of this Section 8.6, a registry user entity search shall include searches of controlled entities.

COMMERCIAL IN CONFIDENCE

8.7 A “self-search” is a search against a particular transacting user entity and, optionally, against its controlled entities, that shall return a priority search certificate for each item of railway rolling stock, in which the transacting user entity or controlled entity is a named party. The searching party may limit the results by date, entity or as otherwise permitted on the website. An electronic notification will be sent to the relevant back-up contact each time a self-search is initiated.

8.6 8.8 Each search certificate and listing shall be issued and made available in electronic form. Upon request, a printed copy of a priority search certificate or Contracting State search certificate shall be provided by the Registrar.

The Registrar may also, at its discretion, when issuing a priority search certificate, provide supplementary priority search information, including:

- (a) the supplemental descriptor;
- (b) information under Section 5.3 subsections (c) (ii) and (iii) being provided by the registry user when making a registration;
- (c) an information table summarizing the registered information in accordance with Section 8.4 (a); or
- (d) the contents of the priority search certificate in a different electronic format, designed to be machine-readable.

Such supplementary priority search information, where provided, is for information purposes only to assist users in reviewing the registered information contained in the priority search certificate. Users must review all registered information contained in the priority search certificate and not just the information contained in the supplementary priority search information. In the case of inconsistency between the registered information contained in the priority search certificate and the supplementary priority search information, the registered information contained in the priority search certificate shall prevail.

Section 9 ~~OPERATIONAL COMPLAINTS~~

9.1 Any person may submit a complaint to the Registrar concerning the operation of the International Registry. If not satisfactorily addressed by the Registrar, that complaint may be further submitted by that person to the Supervisory Authority pursuant to the ~~International Registry~~ Procedures.

9.2 For the purposes of Section 9.1, a matter “concerns the operation of the International Registry” when the matter relates to general procedures and policies of the International Registry and does not involve specific adjudication by the Registrar or Supervisory Authority.

9.3 A person making a complaint shall substantiate his/her assertions in writing.

COMMERCIAL IN CONFIDENCE

9.4 The Supervisory Authority shall promptly consider complaints and where, on the basis of that consideration, it determines changes in the procedures or policies are appropriate, it shall so instruct the Registrar or amend the ~~International Registry~~ Procedures.

~~9.5 The International Registry~~ Any person adversely affected by a unilateral registration who reasonably believes that the registration does not meet the requirements of Section 5.6, 5.12, 5.22 or 5.23 may submit a complaint to the Registrar. Where such adverse effect is substantiated to its reasonable satisfaction, the Registrar shall act in accordance with Section 9.6 below.

9.6 Where a complaint meets the requirements of Section 9.5,

(a) the Registrar may contact the registering person and, where different, the named party listed as the holder of the unilateral registration, to request additional information relating to:

(i) whether the requirements of Sections 5.6, 5.12, 5.22 or 5.23 have been met;

(ii) the complaint and its subject registration; or

(iii) the Registrar's evaluation of such complaint;

and the response shall be provided to the Registrar within 5 calendar days.

(b) the Registrar may, if it deems necessary for the purpose of its evaluation, seek information relating to the registration from the relevant entry point;

(c) where, upon review of the documentary evidence and other relevant information received under the Regulations or under Procedures, the Registrar determines there exists a material risk of misuse of the system, it may suspend or revoke the approval, or disable or block the account, of the relevant registering person's administrator or user; and

(d) the Registrar may make all correspondence and evidence in relation to a complaint under Section 9.5 available to a court;

Provided that the Registrar shall inform the Supervisory Authority when it takes an action under this Section 9.6 (c) and may review its decision upon receipt of additional information.

9.7 No complaint under Section 9.5 may be submitted to the Supervisory Authority.

~~9.59.8~~ The Procedures shall set out details relating to the procedure contemplated by Sections 9.1 to 9.4.

Section 10 CONFIDENTIALITY

All information in the International Registry shall be confidential except where it is:

(a) documentary evidence provided to the Registrar under the Regulations;

~~(a)~~(b) provided by the Registrar in response to a search under Section 8;

COMMERCIAL IN CONFIDENCE

~~(b)(c)~~ made electronically available to enable registry users to effect, amend or discharge registrations;

~~(e)(d)~~ provided to the Supervisory Authority at the latter's request;

~~(e)~~ submitted by the Registrar in court proceedings under Article 44 of the Convention;

~~(f)~~ used for the purposes of the statistics required by Section 11, or

~~(g)~~ provided to a court pursuant to Section 9.6 (d), required to be disclosed by applicable law or authorised to be disclosed by the Supervisory Authority.

Section 11 STATISTICS

11.1 The Registrar shall maintain updated registration statistics and shall publish them in an annual report. This report shall be electronically accessible to any person.

11.2 The registration statistics under Section 11.1 shall consist of

- (a) transactional volumes and revenues, subdivided, in each case, by registration type and geographic distribution; and
- (b) other compilations of non-confidential information requested by the Supervisory Authority.

Section 12 ~~RELATIONS WITH~~ ANNUAL REPORT TO THE SUPERVISORY AUTHORITY

12.1 The Registrar shall prepare an annual report, including statistical data referred to in Section 11, and shall submit it to the Supervisory Authority. The annual report may include recommendations for changes in these Regulations or in the ~~International Registry~~ Procedures.

Section 13 RELATIONS WITH THE DESIGNATED ENTRY POINTS

~~13.1~~ ~~A Contracting State designating an entry point shall notify the Depositary and the Supervisory Authority thereof. The Supervisory Authority shall keep the Registrar informed of such designations.~~

~~13.1~~ 13.2 The Registrar shall maintain a current list of Contracting States that have designated entry points ~~under Article XIII (1) of the Protocol~~. The list shall also identify the entry points, the entities that operate them and their locations and shall be electronically accessible without limitation in the public domain.

COMMERCIAL IN CONFIDENCE

~~13.3~~ An entry point shall transmit a registration when the conditions established by it have been satisfied, such conditions to be consistent with the Convention, the Protocol, and these Regulations, and the named parties in that registration are approved transacting user entities. Subject to the receipt by the International Registry of the consent from each party whose consent is required under the Convention, the Protocol and these Regulations, including, if so required, the named parties in the subject registration, a registration transmitted by an entry point shall be processed when received by the International Registry.

~~13.4~~ Subject to any ~~agreement between a Contracting State and the Supervisory Authority pursuant to Article XIV of the Protocol~~ agreement, but without prejudice to Section 13.3, the Registrar shall establish arrangements applicable to the electronic transmission of registration information from, ~~or authorised by,~~ entry points to the International Registry and, after consultations with each ~~designated~~ entry point, shall specify the procedures and costs applicable to that entry point.

~~13.2~~~~13.5~~ Such arrangements between an entry point and the International Registry shall not impose any additional costs or other material burden on the International Registry and shall not adversely affect the integrity or the functioning of the International Registry system or impose a burden on International Registry resources. The foregoing shall not require the establishment of electronically coordinated systems but rather arrangements designed to enhance the efficient use of the International Registry by entry points.

~~13.3~~ A registration effected in violation of the terms of a designation ~~under Section 13.1 is invalid except where:~~

(a) ~~in the case of an authorizing designated entry point, an authorization code is not obtainable under its procedures (other than due pursuant to failure to comply with such procedures); or~~

~~13.6~~ ~~in the case~~ Article XIII (1) of ~~a direct~~ the Protocol is invalid.

(b) ~~Notwithstanding Section 13.6, a registration effected in violation of the terms of a designation of an entry point, pursuant to Article XIII (1) of the Protocol is not invalid where the use of that~~ the entry point is not permitted under its procedures;

~~13.7~~ and based on the facts of the transaction to which it relates.

~~13.4~~~~8~~ The ~~Registrar~~ International Registry shall provide an electronic warning against a registration that is not effected ~~in accordance with procedures required by~~ through an ~~authorizing~~ entry point where use thereof is mandatory to the extent agreed between the International Registry and the Contracting State ~~declaring~~ designating that entry point.

Section 14 FEES

14.1 Fees in relation to the services provided by the Registrar shall be established and adjusted by the Supervisory Authority as required by the Convention and the Protocol. The fee tariff

COMMERCIAL IN CONFIDENCE

shall be set by a schedule issued by the Supervisory Authority from time to time and which shall state the amount of fees payable for each service. ~~Such~~The fee schedule shall be published by the Registrar at the request of the Supervisory Authority on the website of the International Registry and enter into effect 30 days after that publication.

14.2 The Registrar shall collect a fee prior to undertaking services relating to the International Registry.

The Registrar may also charge a supplement on the fees in excess of the tariffs set out in the ~~Fee Schedule~~fee schedule where payment is made by credit or debit cards or other similar third party payment systems, provided that such supplement shall generally correspond to the Registrar's direct third party costs in collecting such payment.

14.3 Fees, including fees arising from operations through an entry point, must be paid to the Registrar prior to the requested operation unless otherwise agreed between the Registrar and such entry point provided that the Registrar shall not be permitted to require payment more than ~~7~~ days prior to such operation.

Section 15 RELATIONSHIP WITH REGIONAL AND NATIONAL SYSTEMS

Implementing or amending any procedures or mechanisms that involve declared national or regional systems shall require agreement between the Registrar and that system or systems and absent agreement cannot be imposed on that system or systems or vice versa.

Section 16 LIABILITY AND INSURANCE OF THE REGISTRAR

16.1 For the purposes of Article 28 (1) of the Convention, "loss suffered" means loss or damage resulting from an error or omission of the Registrar and its officers and employees or from a malfunction of the international registration system, except as provided for by Article 28 of the Convention, but does not include loss or damage resulting from lack of access to the International Registry as a result of measures referred to in Section 3.3 of these Regulations.

16.2 Any claim against the Registrar under Article 28 (1) of the Convention:

- (a) shall be made in writing within the time period applicable under the laws of the State where the International Registry is located;
- (b) should be made, where practicable, following consultations between the claimant and the Registrar; and
- (c) may be pursued by the claimant in accordance with Article 44 of the Convention.

COMMERCIAL IN CONFIDENCE

- 16.3 ~~The International Registry~~The Procedures shall set out details relating to the procedure contemplated by Section 16.2.
- 16.4 For the purposes of the second sentence of Article XV ~~paragraph (5)~~ of the Protocol, the liability of the Registrar is determined not to exceed 5 million SDRs per event of loss. An event of loss comprises all losses suffered as a result of the same error or omission or malfunction insofar as the losses are compensable under Article 28 ~~paragraph (1)~~ of the Convention.
- 16.5 For the purposes of Article XV ~~paragraph (7)~~ of the Protocol, the amount of insurance or financial guarantee shall not be less than 5 million SDRs per event of loss. The Registrar is obliged to maintain such coverage through insurance or financial guarantee for the term of its appointment and under such conditions as set by the Supervisory Authority.
- 16.6 For the purposes of this Section 16, an error or omission or malfunction relating to more than one item of railway rolling stock registered ~~as part of one~~under group ~~registration~~identifier shall be considered as one event of loss.

COMMERCIAL IN CONFIDENCE

Section 17 INTERNATIONAL REGISTRY PROCEDURES

- 17.1 ~~International Registry~~ Procedures addressing items required by these Regulations or otherwise relating to the technical operation and administrative processes of the International Registry shall be established by the Supervisory Authority and shall be complied with by all registry users, guest users and searching persons. Unless specifically prohibited by the Supervisory Authority, in situations where such operation or processes need to be changed urgently, the Registrar shall be entitled to issue interim amendments to the ~~International Registry~~ Procedures in relation to such changes which shall be notified to the Supervisory Authority as soon as reasonably practicable thereafter and immediately withdrawn if requested by the Supervisory Authority.
- 17.2 Without restricting their content, the ~~International Registry~~ Procedures shall set out the technical and administrative processes for:
- (a) effecting, amending and discharging registrations and making and obtaining copies of searches; and
 - (b) obtaining the approvals and authorizations required to access the International Registry.
- 17.3 Subject to the approval of the Supervisory Authority, the Registrar shall issue guidance notes from time to time concerning the implementation of these Regulations and the ~~International Registry~~ Procedures.

Section 18 PUBLICATION

- 18.1 The authentic version of these Regulations and the ~~International Registry~~ Procedures shall be published in an official publication of the Supervisory Authority on its website.
- 18.2 The Registrar shall make an electronic version of the authentic texts referred to in Section 18.1, as may be amended as contemplated by Section ~~4920~~, available to the public at no cost.
- 18.3 Copyright in all documents published and information displayed on the website of the International Registry or published by the Supervisory Authority, and the domain of the website of the International Registry as identified by the Supervisory Authority in writing shall belong to the Supervisory Authority. The contents of this Section 18.3 shall be prominently displayed by the International Registry on its website.
- 18.4 Section 18.3 shall apply analogously to any other business or social media or applications used by the International Registry for effecting and searching registrations under the Convention and the Protocol.

COMMERCIAL IN CONFIDENCE

COMMERCIAL IN CONFIDENCE

-Section 19 NOTIFICATIONS

The Registrar may notify an administrator or a registry user entity, by email to the current email address provided by or for that person, of any matters affecting the International Registry. Any such notification shall be presumed to have been received 24 hours after it was sent.

Section 20 FINAL PROVISIONS

~~20.20.3~~ Requests for amendments to these Regulations or the ~~International Registry~~ Procedures may be submitted by the Registrar to the Supervisory Authority which shall consider such proposed amendments. In considering any proposed amendments, the Supervisory Authority shall take into consideration the views of rail industry groups. Approval by the Supervisory Authority, in consultation with the Registrar, shall be required to bring any amendments into effect.

~~20.20.4~~ The present Regulations and the initial ~~International Registry~~ Procedures shall take effect on the date the Protocol enters into force. Any amendments to these Regulations or the ~~International Registry~~ Procedures shall take effect 30 days after the date of their publication unless otherwise determined by the Supervisory Authority.

20.5 The validity and priority of, and other rights and interests appurtenant to, a registration made in conformity with the Regulations and the Procedures as in effect at the time of such registration, and taking into account the functional capabilities of the International Registry at such time, shall not be affected by any subsequent change to such Regulations, Procedures or capabilities of the International Registry, and the provision of a facility that allows the parties to a registration to amend or otherwise modify a registration in order to conform to such changes shall not be construed as implying any obligation to effect any such amendment or modification.

20.6 The validity of any action taken by the Registrar in conformity with the Regulations and the Procedures as in effect at the time of such action, shall not be affected by any subsequent change to such Regulations or Procedures.

Appendix

Rail Closing Facility

(Section 5.24 of these Regulations)

1. General

**CONTRACT FOR THE OPERATION OF THE INTERNATIONAL REGISTRY FOR
INTERNATIONAL INTERESTS IN MOBILE EQUIPMENT
(RAILWAY ROLLING STOCK)**

- 1.1 The International Registry may include a closing facility permitting a registry user entity to create a file that may be used to assemble the information required under these Regulations to effect one or more registrations in advance of completing such registrations. For the purposes of this Appendix, such information is referred to as a “prepositioned registration” or “prepositioned registrations”, and the action to assemble such information is referred to as an action to “preposition a registration” or to “preposition registrations”.
- 1.2 A closing facility is not searchable for the purposes of Articles 18 (4) and 19 of the Convention. A prepositioned registration has no legal effect under the Convention or the Protocol until such time as such prepositioned registration has been entered into the International Registry data base in accordance with paragraph 7.2 of this Appendix. Once a prepositioned registration has been entered into the International Registry data base in accordance with paragraph 7.2, it shall be regarded as “registered” (as such term is defined in Article 1 (bb) of the Convention).
- 1.3 This Appendix describes the conditions and procedures for establishing a closing facility, assembling and managing the information required to preposition registrations in the closing facility, consenting to prepositioned registrations and releasing such prepositioned registrations for entry into the International Registry data base so as to become registrations that are searchable and valid under the Convention and the Protocol.
2. Establishing a closing facility
- 2.1 A registry user entity may establish a closing facility by following the directions on the International Registry website.
- 2.2 The registry user entity who establishes a closing facility, the “coordinating entity”, shall have the responsibilities for the closing facility described in this Appendix.

COMMERCIAL IN CONFIDENCE

- 2.3 Each closing facility shall have a unique identifier automatically assigned by the International Registry, the “closing facility ID”, and registry users may search for a closing facility on the International Registry website using the closing facility ID.
- 2.4 The coordinating entity may extinguish a closing facility at any time prior to taking the action described in paragraph 7.1.

COMMERCIAL IN CONFIDENCE

3. Assembling and managing closing facility registrations

3.1 The coordinating entity shall be responsible for assembling and managing all the information required to preposition registrations in the closing facility. The registry users of the coordinating entity, and no other persons, will be entitled to enter or modify information in the closing facility. References in this Appendix to action by a coordinating entity shall mean action on its behalf by any of its registry users.

3.2 In order to preposition a registration, the coordinating entity must enter all of the information for that category of registration specified in the applicable section of these Regulations. For example, all the information specified in Section 5.3 of these Regulations shall be required to preposition a registration of an international interest. In addition, if any item of railway rolling stock is the subject of more than one prepositioned registration, the coordinating entity shall specify the chronological order in which, when released, such prepositioned registrations are to be entered into the International Registry data base.

3.3 After the coordinating entity has completed assembling the information required to effect all of the prepositioned registrations to be included in the closing facility, following the directions on the International Registry website, it may suspend the ability to amend or enter further registration information (referred to as designating the closing facility as “locked”). The locked status of the closing room will (a) initiate the actions described in paragraph 4.1, and (b) signify that all the information for the prepositioned registrations in the closing facility has been assembled and that the closing facility is available for each registry user entity whose consent is required under these Regulations to take one of the actions specified in paragraph 4.2.

3.4 A coordinating entity may at any time (whether or not a closing facility has been locked) provide any registry user entity and any registry user with “read only” access to such closing facility to read, but not modify, the information contained therein by following the directions on the International Registry website for identifying such persons and establishing such access. Once the closing facility is locked, each registry user entity whose consent to the registrations prepositioned in the closing facility is required under these Regulations, shall automatically have read only access to such closing facility. The registry user entities and registry users with access rights to the closing facility are referred to as the “closing facility participants”.

3.5 A coordinating entity may transfer its rights and responsibilities to another registry user entity as its replacement. Such a transfer shall take effect when the administrator for the transferee registry user entity gives its acceptance in the manner specified on the International Registry website, and shall have the effect specified in paragraphs 5.1 and 5.2.

4. Consenting to prepositioned registrations

4.1 When the coordinating entity designates the status of a closing facility as locked, the International Registry shall issue to the closing facility participants a notice:

(a) identifying the coordinating entity;

(b) providing access to the closing facility and setting forth the closing facility ID;

COMMERCIAL IN CONFIDENCE

(c) stating that the closing facility is available for each registry user entity whose consent is required under these Regulations to take the action specified in paragraph 4.2;

(d) stating the period of time (as provided by paragraph 5.3) that the closing facility will remain accessible for the purpose of providing consent or reviewing information; and

(e) attaching a “pre-registration report” that shows all prepositioned registrations, including the specified chronological order of any multiple registrations for an item of railway rolling stock.

4.2 After the notice described in paragraph 4.1 has been issued, each registry user entity whose consent is required under these Regulations may consent or decline to consent to such prepositioned registration by following the directions on the International Registry website.

4.3 A consent to a prepositioned registration may be revoked at any time prior to release of that prepositioned registration for entry into the International Registry data base, as described in paragraph 7.1.

4.4 A registry user entity who has declined to give a consent or has revoked a consent shall be entitled to reverse that action at any time prior to the release of its prepositioned registration for entry into the International Registry data base, as described in paragraph 7.1.

4.5 Revoking an authorization under which a consent to a prepositioned registration was given, including an authorization provided to a professional user, will have the effect of revoking such consent. In order to reverse that action, the registry user entity must either consent to such prepositioned registration, or re-issue its authorization to another registry user entity who then consents to such prepositioned registration, with such action occurring in each case at any time prior to the release of such prepositioned registration for entry into the International Registry data base, as described in paragraph 7.1.

4.6 As provided in paragraph 7.1, none of the prepositioned registrations in a closing facility may be released into the International Registry data base unless all such prepositioned registrations have been consented to by or for each registry user entity whose consent is required by these Regulations, and such consents are in effect at the time that the coordinating entity issues a release instruction (as defined in paragraph 7.1).

5. Making changes to prepositioned registrations

5.1 Although a closing facility may not be modified while it is locked (except as provided in paragraph 8), the coordinating entity may make changes to the prepositioned registrations, whether on its initiative or in response to requests by closing facility participants, or transfer its responsibility as coordinating entity to another registry user entity, by following the directions on the International Registry website for reinstating the ability to change or enter further information (referred to as designating the closing facility as “unlocked”).

5.2 If a closing facility is unlocked, all consents to prepositioned registrations will be cancelled automatically, the closing facility will revert to the status described in

COMMERCIAL IN CONFIDENCE

paragraph 3, and the International Registry will issue a notice to all the closing facility participants advising that the closing facility has been unlocked and that the pre-registration report issued with respect to the closing facility has lapsed. The coordinating entity may then change the prepositioned registrations and lock the closing facility with such changes in place, at which time the provisions of paragraphs 4.1 to 4.4 shall apply.

5.3 If the prepositioned registrations in a closing facility have not been released for entry into the International Registry data base, as described in paragraph 7.1, prior to the expiry of ten (10) calendar days following the date that the closing facility is locked, the closing facility shall become unlocked automatically, with the effect described in paragraph 5.2. Notwithstanding the foregoing, the coordinating entity may extend the locked period for a closing facility for ten (10) additional calendar days up to a maximum of eleven (11) times in succession. Notice of any such extension shall be issued to the closing facility participants by the International Registry.

6. Payment of fees

6.1 At any time after a closing facility has been locked, but prior to the issuance of a release instruction under paragraph 7.1, the coordinating entity shall pay the fees in respect of all prepositioned registrations in the closing facility.

6.2 Such payment shall be final if such prepositioned registrations are released for entry into the International Registry data base, as described in paragraph 7.1.

6.3 If such prepositioned registrations are not so released, the coordinating entity shall be entitled to a refund of such fees, less applicable third party payment processing expenses.

7. Entering prepositioned registrations into the International Registry data base

7.1 The coordinating entity may, by following the directions on the International Registry website, issue an instruction to the International Registry, a "release instruction", to enter all the prepositioned registrations in the closing facility into the International Registry data base in the chronological order specified in the pre-registration report and make them searchable for the purposes of Articles 18 (4) and 19 of the Convention when all of the following conditions are satisfied:

(a) the closing facility is locked;

(b) all prepositioned registrations in the closing facility have been consented to by or for each registry user entity whose consent is required by these Regulations;

(c) the fees referred to in paragraph 6.1 have been paid; and

(d) if applicable, the special procedures and conditions described in paragraph 8 have been completed and satisfied.

7.2 Upon receipt of a release instruction, the International Registry shall cause all the prepositioned registrations in the closing facility to be entered into the International Registry data base in the chronological order specified in the pre-registration report and made searchable for the purposes of Articles 18 (4) and 19 of the Convention. When so entered into the International Registry data base, each of the prepositioned registrations

COMMERCIAL IN CONFIDENCE

and consents thereto shall be a “registration” and a “consent” to such registration, as such terms are defined in these Regulations, and each such registration shall be “registered” for the purposes of the Convention.

7.3 After the prepositioned registrations in the closing facility have been entered into the International Registry data base, the closing facility shall be extinguished. However, the Registrar shall retain a record of the pre-registration report. Any closing facility participant may obtain a copy of the pre-registration report by following the directions on the International Registry website.

7.4 The closing facility participants shall report to the Registrar within 72 hours from the issuance of the release instruction any discrepancies between the registrations that have been entered into the International Registry data base and the pre-registration report. Any such discrepancies shall be subject to correction in accordance with Section 5.19 of these Regulations.

8. Special conditions and procedures applicable to entry points

The foregoing conditions and procedures may be modified under the terms of a Contracting State agreement with respect to any registrations that are subject to Section 13 of these Regulations relating to entry points.

© Copyright to the Preparatory Commission regarding the establishment of the International Registry for railway rolling stock according to the Luxembourg Protocol to the Cape Town Convention on International Interests in Mobile Equipment, 2021

COMMERCIAL IN CONFIDENCE

ATTACHMENT III

COST SCHEDULE

The figures below are provided as an indicative estimation of the set-up and ~~running~~operational costs of the Prime Subcontractor and Contractor. The cost table below is based on the indicative costs provided in the attachment approved as part of the 2014 contract.

~~1. Establishment and Development Costs of the Registrar~~

1.1. Legal Expenses — €200,000

An estimation of the external legal fees associated with legal separation assessment, establishing Contractor, review of Prime Subcontractor & Contractor contracts and post signature review. The figure is based on quotes from external organizations which have provided advice important to the International Aircraft Registry when it was formed and as it has developed.

A breakdown of effort is as follows:

- 30% — post signature review and report
- 21% — legal establishment of Contractor
- 19% — legal separation assessment
- 17% — review of Contractor contract
- 13% — review of Prime Subcontractor contract [similar costs associated with a Prime Subcontractor review of the contract to ensure separacy appear in the “All Other” section of the Prime Subcontractor establishment costs in section 3.4 below.]

The external activity includes:

- Confirm if the proposed structure for Contractor and Prime Subcontractor provide sufficient legal separation so as not to expose Prime Subcontractor to Article 28 liability under the Convention for either Rail or Aviation based on the Legal Separation paper prepared for the set up of the International Aircraft Registry.
- Buy off the shelf company and implement relevant legal separation items in the corporate documents and provide generic duties to directors and establish first Board Meeting and minutes to (i) appoint Directors (ii) appoint auditors (iii) approve articles etc (iv) approve and sign contracts.
- Review contract for report to Contractor Board.
- Review procedures based on procedures for Aviation to ensure optimum contractual protection for Contractor
- Create website User terms and conditions based on website User terms and conditions for Aviation to ensure optimum contractual protection for Contractor
- Create website User terms and conditions based on Original website User terms and conditions for Aviation to ensure optimum contractual protection for Prime Subcontractor
- Review Certification Practice Statement (CPS) based on CPS for Aviation to ensure optimum contractual protection for Contractor
- Review contract between Prime Subcontractor and Contractor for legal separation
- Create insertion as per Irish Legislation re certificate production
- Support to conclude contract
- Support to conclude contract with Subcontractor

COMMERCIAL IN CONFIDENCE

1.2. All other — €34,167

Miscellaneous cost items, including furniture and fixtures, hiring costs and administration. These break down as follows:

○ Furniture	€10,000
○ Establishment	€7,500
○ Hiring	€10,000
○ Administrative	€6,667

2. Yearly Operating note that Costs of the Registrar

2.1. Personnel — €437,000

This is an estimated cost, based on employing a Registrar, Director of Operations, an Assistant and an Intern; all based in Luxembourg including local social charges. Assumed salaries used were:

○ Registrar	€225,000
○ Director of Operations	€125,000
○ Assistant	€62,000
○ Intern	€25,000

2.2. Audit and Professional Services — €156,618

Annual estimated fees covering charges for audit, legal services, financial and treasury management based upon actual costs at the Aircraft Registry. These break down as follows:

- Financial Audit of Contractor and additional costs of auditing OpsCo as part of Prime Subcontractor
- Legal advice during the operation of the International Registry, based upon the fees currently paid by Aviareto for advice in operating the Aircraft registry
- Professional Finance and Treasury managements services, again based upon the actual fees paid by Aviareto for these services.

2.3. Security Review — €58,824

Cost of conducting an annual security review in keeping with best practice and based on Aviareto experience and actual costs. This covers an annual security audit and scan of the ICT infrastructure of the International Registry and an annual follow up on recommendations from the Audit to be completed by a respected industry name. The costs are based on those of Aviareto in its role as Registrar of the Aircraft registry.

2.4. All Other — €105,000

Miscellaneous charges covering insurance, marketing, office facilities and third party customer surveys. These break down as follows:

○ Promotion and marketing	€35,000
○ Insurance	€50,000
○ Customer survey	€15,000

COMMERCIAL IN CONFIDENCE

~~o Luxembourg offices €5,000~~

~~2.5. Secretariat – €15,000~~

~~Secretariat charges as specified in the RFP.~~

~~3. Establishment and Development Costs of Prime Subcontractor~~

~~3.1. Hardware Assembly – €519,784~~

~~This is based on the result of a competitive process involving five organizations, to identify the most suitable provider of hardware and hosting services for the International Aircraft Registry. Fujitsu were selected as the chosen supplier, which also enabled us to leverage the existing relationship and services provided by them to Aviareto. The total amount is split into components of Server & Storage, Networking, Software and Professional Services as follows:~~

~~o Server & Storage – €86,057~~

~~This is the hardware, such as web, application and database servers and specialised, resilient data storage equipment.~~

~~o Networking – €92,985~~

~~This covers LAN and WAN infrastructure, such as firewalls, switches, routers, cabling etc. Linking all the devices in a secure manner to the outside world.~~

~~o Software – €66,790~~

~~This is the core, off the shelf software such as Operating System, and Oracle Database management system upon which the International Registry application indicative estimates and will run.~~

~~o Professional Services – €273,952~~

~~This is a resource based cost covering specialist IT expert personnel in the following areas: hardware be refined and further detailed during design, build, configuration and installation; installation and configuring the operating system; installation and configuration of the Oracle database management systems; detailed design, installation and configuration of the network components, in particular the firewall security; configuration of management system to send and receive alert notifications; final security hardening of all components. Additional personnel will carry out system testing of the above components. In addition there will be Project Management resource to coordinate the above activities and Technical Authorship to produce support documentation. The above activity is estimated at 253 man days of effort based on experience in systems build and in particular previous experience with the aviation registry.~~

~~In order to ensure value for money, we recently tested the hosting market again and have received additional quotations from ebre based in Luxembourg. This was significantly (in excess of 20%) more expensive than the quote from Fujitsu from both a one off and on-going basis.~~

~~3.2. Software Creation – €567,500~~

COMMERCIAL IN CONFIDENCE

~~This covers establishment and development resource time to create the necessary software components, including:~~

- ~~o 2 Business Analyst~~
- ~~o 5 Developers~~
- ~~o 3 Quality Assurance & Testing Analysts~~
- ~~o 1 Project Manager~~

~~The Business Analysts develop the specification for the Rail Registry based upon the regulations and the content of Prime Subcontractor's response to the RFP. This is then passed to the Developers who write the software code. Quality and Testing Analysts develop and execute test plans to during and post development to ensure the software meets the specification and is of high quality. The Project Manager coordinates all activities and acts as single point of contact for the development team. All resource is expected to be engaged for the full duration of the development, estimated at 35 weeks.~~

~~After a competitive process for the International Aircraft Registry involving three companies, Prime Subcontractor was selected as the software developer and approved by ICAO. This enabled us to leverage the existing Aviareto relationships and core systems. As the software proposed for the International Rail Registry is to be based upon the latest Aircraft Registry software, it is necessary to use the same supplier under similar terms. We estimate that in excess of \$6m has already been spent by the Aircraft Registry on developing this core system, to the benefit of the Rail Registry.~~

~~3.3. Software Approval & Certification – €107,000~~

~~This is an estimate based on quotes received from PwC to carry out testing and audit services. This is to provide an independent third party examination of the software and security so to ensure that they cannot be manipulated, and to ensure that the design is adequate. PwC were chosen following a competitive process for the International Aircraft Registry in 2009 which included Deloitte and EDS.~~

~~3.4. All other – €104,167~~

~~Comprised of miscellaneous cost items including furniture and fixtures, hiring costs, legal expenses, administration, and professional services relating to the high level design of the hardware and software environments to create high level design documentation which will then feed into the Professional Services described above. These numbers break down as follows:~~

- ~~o Furniture – €10,000~~
- ~~o Legal – €20,000~~
- ~~o Administrative – €6,667~~
- ~~o Software design – €30,000~~
- ~~o Hiring – €10,000~~
- ~~o Hardware design – €20,000~~
- ~~o Other – €7,500~~

~~4. Yearly Operating Costs of Prime Subcontractor~~

~~4.1. phases. Personnel – €431,000~~

COMMERCIAL IN CONFIDENCE

This is an estimated cost based on employing a ~~General Manager~~ and three Registry Officials located in Dublin. The cost is made up from basic salary estimations (using Aviareto experience and market information), and employer costs including pensions, health insurance, social welfare costs etc. Assumed salaries used were:

- o ~~General Manager~~ — €125,000
- o ~~Registry Official~~ — €62,000

~~4.2. Hardware Maintenance and Hosting — €385,723~~

~~This is a quote from Fujitsu, selected after a competitive process, for providing a hosted environment for the hardware, including maintenance support. As previously described, Fujitsu were selected after a competitive process that determined they offered the best cost-benefit solution. This quote includes a hardware refresh after 5 years. The details of the hardware environment are included in the relevant service schedule of the SITA contract.~~

~~A recent alternate quote from EBRC gave an annual recurring cost that was approximately 25% more expensive than the one quoted above from Fujitsu.~~

~~4.3. Software Maintenance and Support — €253,714~~

~~This represents an estimate of the charges associated with providing software maintenance, support to agreed service levels and minor enhancements, based on Aviareto experience. Typically in the market, this software maintenance forms 15-20% of the full software development initial charges. For the Rail Registry, it should be noted that much of the development of the core software components came from the Aircraft Registry system. As such, the Software Maintenance figure above appears to be a higher percentage than market norms. To be clear however, neither Registry is funding the others maintenance or support. Given the estimated costs of developing both Aircraft and Rail Registry software, this figure represents approximately 10% of total software cost. that these costs are also based on 2014 estimates, it is anticipated some overall adjustments to account for matters including market adjustments and cost of living increases may be required for certain items (ie. insurance, salaries).~~

~~4.4. Certificates — €62,000~~

~~This is an estimate of the annual costs associated with digital certificates following discussions with VeriSign / Symantec. We expect to be able to leverage the existing relationships and purchasing power of Aviareto in order to ensure competitive pricing. This is significantly less than Aircraft Registry is currently paying for its certificates.~~

~~4.5. All Other — €128,667~~

~~Miscellaneous charges covering insurance, legal and other professional services, ISO certification and audit, and office facilities. These break down as follows:~~

- o ~~Insurance~~ — €10,000
- o ~~Legal, audit and professional~~ — €52,000
- o ~~ISO Certification and Audit~~ — €15,000
- o ~~Dublin costs~~ — €47,000
- o ~~Additional language~~ — €4,500

5. Prime Subcontractor Monthly Charges to Contractor

COMMERCIAL IN CONFIDENCE

<u>Year</u> <u>Phase</u>	<u>Costs</u> <u>Monthly</u> <u>Amount</u>	<u>Included Items</u>
<u>Establishment and</u> <u>Development Costs of the</u> <u>Registrar</u> <u>Year 1</u>	€115,437,235,000	<u>Legal Expenses, Hiring Costs, Administration</u> <u>and Set-Up</u>
<u>Year 2</u> <u>Annual Registrar</u> <u>Operating Costs (subject to</u> <u>inflation adjustments)</u>	€117,169,435,000	<u>Personnel</u>
<u>Year 3</u>	€118,926,155,000	<u>Audit and Professional Services</u>
<u>Year 4</u>	€120,710,163,000	<u>Audit, Insurance and Other Services</u>
<u>Year 5</u>	€122,521,26,000	<u>Secretariat Charges</u>
<u>Year 6</u> <u>Establishment and</u> <u>Development Costs of the</u> <u>Prime Subcontractor</u>	€124,358,515,000	<u>Infrastructure, Security and Set-Up</u>
<u>Year 7</u>	€126,224,565,000	<u>Software Configuration and Development</u>
<u>Year 8</u>	€128,117,105,000	<u>Software Audit and Testing</u>
<u>Year 9</u>	€130,039,100,000	<u>Design, Administrative and Other Expenses</u>
<u>Year 10</u> <u>Annual Operating</u> <u>Costs of Prime</u> <u>Subcontractor (subject to</u> <u>inflation adjustments)</u>	€131,990,430,000	<u>Personnel</u>
	€698,000	<u>Application Maintenance and Support, Hosting,</u> <u>Security, Certificates and Testing</u>
	€125,000	<u>Insurance, Audit, Facilities and Other Expenses</u>

Celle inserite

The monthly charges above reflect a 1.5% annual inflation adjustment with respect to the operating cost component of the fee and no inflation adjustment to the establishment cost component.

The Contractor may second its personnel to another part of the SITA-SC group of companies, ISC or to third parties at arm's length, rates, Rates and income there from shall be credited against its yearly operating costs.

COMMERCIAL IN CONFIDENCE

**CONTRACT FOR THE OPERATION OF THE INTERNATIONAL REGISTRY FOR
INTERNATIONAL INTERESTS IN MOBILE EQUIPMENT
(RAILWAY ROLLING STOCK)**

COMMERCIAL IN CONFIDENCE

ATTACHMENT IV

PERFORMANCE BOND

Guarantee no:

Guarantor: [Issuing bank] [address in UK]

Applicant and instructing party: Regulis S.A. having its registered address at L-1330 Luxembourg, 48, boulevard Grande-Duchesse Charlotte, Grand-Duché de Luxembourg

Beneficiary: The Supervisory Authority established in accordance with Article 17 of the Cape Town Convention on International Interests in Mobile Equipment and Article XII (1) of the Protocol thereto on matters specific to railway rolling stock (the "Luxembourg Protocol").

The Contract:

The Applicant and the Preparatory Commission, established by Resolution No. 1 of the Diplomatic Conference adopted on 23rd February 2007 in Luxembourg to adopt the Luxembourg Protocol, acting in its capacity as Provisional Supervisory Authority, have entered into a contract dated 12th November 2014 regarding the appointment of the Applicant as the exclusive contractor to establish the International Registry pursuant to the Luxembourg Protocol.

Guarantee amount and currency: EUR 150,000 (Euro one hundred and fifty thousand).

Documents required:

A Statement purportedly signed by an authorized representative of Beneficiary:

- (a) giving full details of the Applicant's default with reference to particular article(s) of the Contract and the amount called by Beneficiary within the limit of this Guarantee; and
- (b) confirming that the Applicant has been given no less than the period allowed by the Contract to remedy such default; and
- (c) accompanied by the following documentary evidence of the said default:
 - (i) A copy of letter to the Applicant advising the Applicant of the default and expressly advising Applicant of the period allowed under the Contract to remedy such default (but in any case not less than 30 days); and
 - (ii) A statement that the Applicant has not denied the default, or, in the absence of such a statement, a certification that Applicant has not remedied the default within the period allowed by the Contract.

Language of any required documents: English.

Form of presentation: Paper.

Place for presentation: Guarantor's counters.

Liability for charges: with the Guarantor.

Transferability: This Guarantee is transferrable by the Beneficiary.

COMMERCIAL IN CONFIDENCE

Expiry of guarantee:

This Guarantee will expire on the date which is one year after the expiry or sooner termination of the Contract.

Applicable Law and Jurisdiction:

English law. Disputes subject to the exclusive jurisdiction of the High Court of England and Wales.

As Guarantor, we hereby irrevocably undertake to pay Beneficiary any amount up to the guarantee amount upon presentation of Beneficiary's complying demand, in the form of presentation indicated above, supported by such other documents as may be listed above and in any event by the Beneficiary's statement, whether in the demand itself or in a separate signed document accompanying or identifying the demand, indicating in what respect applicant is in breach of its obligations under the underlying relationship.

Any demand under this Guarantee must be received by us on or before expiry at the place for presentation indicated above.

This Guarantee is subject to the uniform rules for demand guarantees (URDG) 2010 revision, ICC publication no. 758.

.....
Duly authorised signatories for and on behalf of the Guarantor

.....
Date/location

Note: The Preparatory Commission and the Applicant will need to agree in advance on what institutions will be the issuing bank and the guarantor.

COMMERCIAL IN CONFIDENCE

~~CONTRACT FOR THE OPERATION OF THE INTERNATIONAL REGISTRY FOR
INTERNATIONAL INTERESTS IN MOBILE EQUIPMENT
(RAILWAY ROLLING STOCK)~~

COMMERCIAL IN CONFIDENCE

ATTACHMENT V

Model License Agreement

THIS ~~LICENSE~~LICENSE AGREEMENT (the "License Agreement" ~~(the "License Agreement")~~) is made on the date which is the date the last of the signatories hereto signs this ~~License~~License Agreement (the "Effective Date" ~~(the "Effective Date")~~).

BETWEEN:

(1) ~~Regulis S.A.~~^{****} ("Licensee"), and

(1) ~~Enterprise Registry Solutions Limited~~, a company registered in ~~Luxembourg~~Ireland with company number ~~[]~~358857 having its principal office at ~~L-1330 Luxembourg, 48, boulevard Grande-Duchesse Charlotte, Grand-Duché de Luxembourg~~ ("Licensee"), and

(2) ~~SITA Information Networking Computing (Ireland) Limited~~ a company registered in ~~office at Level 2, Number 4, Customs House Plaza, Harbourmaster Place, Dublin 1, Ireland~~ with company number ~~369682~~ having its principal office at ~~Building 1, Letterkenny Office Park, Windyhall, Letterkenny, Co. Donegal, Ireland~~ ("~~SITA~~" ("ERS").

WHEREAS:

~~SITA~~
(A) ~~ERS~~ has been providing services in connection with the operation of the International Registry, and in so doing has used ~~a certain Source Code and Object Code~~Licensed Program;

(B) The Supervisory Authority under the authority of the Cape Town Instruments has awarded the Licensee the contract to continue the operation of the International Registry and the Licensee has signed the New Registrar Contract with the Supervisory Authority for the operating of such an International Registry; and

(C) The Licensee wishes to ~~license~~license the Licensed Program for the purposes of operating the International Registry.

THE PARTIES HERETO AGREE AS FOLLOWS:

1. Scope of the Agreement

The scope of this ~~License~~License Agreement is the acquisition, in accordance with this ~~License~~License Agreement, of a limited ~~license~~license of the Licensed Program for the sole purpose of operating and developing the International Registry for the Term.

2. Grant of ~~License~~License and Authorised Use

~~2.1~~

2.1 Delivery

As soon as practically possible (but in any event no later than 72 hours after the Effective Date), ~~SITA~~ERS will deliver to the Licensee the then current version of the ~~License~~License Materials.

COMMERCIAL IN CONFIDENCE

~~2.2~~ License

~~2.2~~ SITA License

ERS hereby grants to the Licensee, a non-exclusive, worldwide, revocable, non-transferable, limited ~~license~~ to access, operate, reproduce, perform, load, execute, display, store, modify, enhance, create derivatives of and otherwise use the Licensee Licensed Materials for the sole purpose of the International Registry in accordance with the terms and conditions of this Licensee License Agreement for the duration of the Term.

2.3 Licensee Responsibility

The Licensee accepts responsibility for (a) the selection of the Licensed Program to meet the Licensee's Licensee's requirements and to achieve the desired results, (b) the use of the Licensed Program, (c) the commercial results obtained from the Licensee's Licensee's use of the Licensed Program and (d) liability under Article 28 of the Convention.

2.4 Scope of Use and Access to Software by Third Parties

The Licensed Program and the Documentation will be utilized by the Licensee for the operation and development of the International Registry by adding, modifying and enhancing the Licensed Program in order to meet the requirements of the International Registry. The Licensee shall have the right to modify or enhance the Licensed Program, ~~including, without limitation, adapting or modifying the Source Code or the Object Code ("Licensee Enhancements")~~. ("Licensee Enhancements"). Any intellectual property rights in Licensee Enhancements shall belong to the Licensee and shall not be part of the Licensed Program.

The Licensee shall not use the services of any then current direct competitor of SITAERS for the modification of the Licensed Program or development of the ~~Licensed Program~~. Licensee Enhancements.

Prior to giving access to the Licensee Licensed Materials to a third party the Licensee shall obtain written consent from SITAERS, such consent not to be unreasonably withheld or delayed, and ensure that such third party duly executes the "Third Party Access Agreement" substantially in the form as attached hereto as Annex 1.

2.5 Backups

The Licensee may make unlimited copies of the ~~Licensed Program and~~ Documentation for archival and disaster recovery purposes and for use in accordance with this clause 2. The Licensee will keep current, detailed records of each such copy made, including its current location, form and disposition. ~~;~~ If Licensee uses a third party to provide disaster recovery services, Licensee will require such third party to execute a confidentiality agreement containing terms and conditions no less restrictive than those set forth in clause 6.

~~2.6~~ Branding

~~2.6~~

COMMERCIAL IN CONFIDENCE

Licensee will not alter, conceal or remove any copyright, trade secret, patent, proprietary or other legal notice contained on or in the Licensed Program or the Documentation. Licensee will include or create on or in all copies of the Licensed Program and the Documentation the exact form of any such notices.

2.7 Safeguards

The Licensed Program and the Documentation are being disclosed by [SITAERS](#) to Licensee in confidence. Licensee will implement and maintain precautions, no less rigorous than those Licensee uses to protect its own confidential information, but in no event less than reasonable precautions, to safeguard the Licensed Program and the Documentation so that no unauthorized persons have access to the Licensed Program or the Documentation and that no persons authorized to have such access will take any action that would violate the confidentiality obligations of this [LicenseeLicense](#) Agreement. Licensee will promptly report to [SITAERS](#) any actual or suspected violation of the confidentiality obligations of this [LicenseeLicense](#) Agreement. Licensee will, at its expense, take such reasonable steps as [SITAERS](#) may request to remedy any such violation, including retrieving any portion of the Licensed Program or the Documentation that is being used, or is otherwise possessed, in breach of this [LicenseeLicense](#) Agreement, and will pay or reimburse [SITAERS](#) all reasonable expenses that [SITAERS](#) reasonably incurs which are related to the remedy of any such violation.

2.8 Injunctive Relief

Licensee acknowledges and agrees that the Licensed Program and the Documentation are the valuable property and trade secrets of [SITAERS](#), that any violation by Licensee of the confidentiality obligations of this [LicenseeLicense](#) Agreement would cause [SITAERS](#) irreparable injury for which it would have no adequate remedy in damages and that, in addition to any other remedies that [SITAERS](#) may have, it will be entitled to preliminary and other injunctive relief against any such violation. This clause 2.8 will not limit either [party's](#) right to seek injunctive relief for any other violation of this [LicenseeLicense](#) Agreement, including a breach of clause 6.

2.9 Investigation

During normal business hours, with reasonable notice to Licensee and without causing undue business disruption to the Licensee, [SITAERS](#) may conduct an investigation, through a designated representative that is not a competitor of Licensee and at [SITAERS's](#) expense, to determine Licensee's compliance with the terms and conditions of this [LicenseeLicense](#) Agreement. Licensee will allow such designated representative to have access to any records (in whatever form kept by or on behalf of Licensee) relating to this [LicenseeLicense](#) Agreement and Licensee's use of the Licensed Program and the Documentation.

3. Ownership

3.1 Licensed Program

COMMERCIAL IN CONFIDENCE

For all purposes, [SITAERS](#) will be considered the owner of the Licensed Program and the Documentation and of all Intellectual Property Rights contained or evidenced therein but the Licensee Enhancements shall belong to the Licensee together with all Intellectual Property Rights contained or evidenced therein. ~~All copies of the~~ The Licensed Program and [all copies of](#) the Documentation will remain the property of [SITAERS](#). The provisions of this clause 3 will survive the termination of this [LicenseeLicense](#) Agreement for any reason.

3.2 Derivative Works

In accordance with the terms of the [LicenseeLicense](#) in clause 2.2, but subject to clause 2.4, of this [LicenseeLicense](#) Agreement the Licensee is only permitted to create derivative works of the Licensed Program for the International Registry and will only use such derivative works for the purposes of the International Registry.

4. Warranties

4.1 Warranty on Licensed Program

Whilst [SITAERS](#) has used reasonable care and skill in designing the Licensed Program, the Licensed Program is licensed to Licensee "AS IS" and, to the extent permissible by law, no warranty other than expressly provided in this [LicenseeLicense](#) Agreement is provided by [SITAERS](#) (a) in relation to the Licensed Program or (b) the uses to which it may be put or (c) its fitness or suitability for any particular purpose or under any special conditions.

4.2 Documentation

[SITA](#)

[ERS](#) warrants that the Documentation contains all written materials prepared by or on behalf of [SITAERS](#) in relation to the International Registry.

4.3 Disclaimer

Except as otherwise expressly provided in this clause 4, neither party makes any representations or warranties, express or implied, regarding any matter, including the merchantability, suitability, originality, fitness for a particular use or purpose, or results to be derived from the use, of any information technology service, software, hardware or other materials provided under this [LicenseeLicense](#) Agreement. In particular, [SITAERS](#) does not warrant that the operation of the Licensed Program will be uninterrupted or error-free.

5. Maintenance and Support

Licensee acknowledges that the Licensed Program is provided under this [LicenseeLicense](#) Agreement without maintenance or support services from [SITAERS](#) and Licensee agrees to be responsible for software maintenance and support services in relation to the Licensed Program.

COMMERCIAL IN CONFIDENCE

6. Confidentiality

6.1 Confidential information

Licensee and [SITAERS](#) acknowledge that they will receive confidential information and trade secrets ~~(**"Confidential Information"**)~~ from each other in connection with this [LicenseeLicense](#) Agreement. Subject to clause 6.3, Confidential Information will be deemed to include all the information each party receives from the other, except anything expressly designated as not confidential. Licensee and [SITAERS](#) agree to maintain the secrecy of the Confidential Information and agree neither to use it (except for purposes of performing hereunder) nor to disclose it to any person other than their employees who have a need to know in order to perform their obligations under this [LicenseeLicense](#) Agreement.

6.2 Release

The parties acknowledge and confirm that the contents of, and their performance under this [LicenseeLicense](#) Agreement constitute, for the purposes of this clause 6 (Confidentiality), Confidential Information. Notwithstanding the foregoing, neither party will be prevented from releasing any public press, trade or other announcement stating that an agreement has been concluded between the parties, nor shall a party be precluded from disclosing Confidential Information to its professional advisers, auditors and others under a professional duty of confidentiality or in order to enforce the terms of this [LicenseeLicense](#) Agreement.

6.3 Exclusions

Confidential Information will not include any information which is publicly available at the time of disclosure or subsequently becomes publicly available through no fault of Licensee or [SITAERS](#), or is rightfully acquired from a third party who is not in breach of an agreement to keep such information confidential.

6.4 Disclosure required by law

6-4

Nothing contained in this clause 6 (Confidentiality) will prevent either party from disclosing any Confidential Information of the other party to regulatory agencies and/or government authorities, to the extent that such disclosure is required by law, rule, regulation or government or court order. In such event, the disclosing party will take all reasonable steps to maintain the confidentiality of such Confidential Information to be disclosed and shall forthwith advise the other party of such impending disclosure.

6.5 Survival

The obligation of the parties under this clause 6 shall remain in force for a period of five years after the end of the Term.

7. License Fee

7.1 License Fee

In consideration of SITAERS making the Licensed Program and the Licensee Licensed Materials available to the Licensee, the Licensee will pay to SITAERS:

- (i) The Software Residual Negotiated Value pursuant to a payout schedule agreed to by SITAERS and the Licensee, in any event no longer than 3 (three) years; and
- (ii) An amount of US\$ 100 per calendar year from the Effective Date until the end of the Term (pro rata for a part of a year).

7.2 Taxes

The Licensee License Fee does not include taxes, and Licensee must pay all taxes arising under this Agreement, excluding income taxes that are based on or measured by SITAERS's income or gains or any penalty payments or duties in relation to late or non-payment of taxes by SITA-ERS.

8. Term and Termination

8.1 Term

This Licensee License Agreement shall remain in full force and effect for the Term.

8.2 Termination by Either Party

- 8.2.1. Licensee may terminate this Licensee License Agreement by notice to SITAERS on three (3) ~~months~~ months notice at any time.
- 8.2.2. Licensee Either party may terminate this Licensee License Agreement by notice to ~~SITA~~ the other party (the "Defaulting Party") with immediate effect if ~~SITA~~ the Defaulting Party commits a material breach of its obligations in this Licensee License Agreement and does not remedy that breach within thirty (30) days of receiving a notice detailing the breach and requiring that it be rectified.

~~8.2.3~~ Consequences of Termination

- 8.3.1. In the event of a material breach of its obligations under this Agreement by Licensee, Licensee may continue to use the Licensee License in accordance with this Licensee License Agreement provided it compensates SITAERS for any damages assessed in accordance with applicable law.
- 8.3.2. At SITAERS's request the Licensee shall, on termination of this Licensee License Agreement, execute a certificate of destruction in relation to any material associated with the Licensed Program (other

COMMERCIAL IN CONFIDENCE

than Licensee Enhancements) to SITA-ERS's satisfaction and any such execution shall be legalized in accordance with the Licensee's/Licensee's jurisdiction of operation.

9. Limitation of liability

9.1 Exclusions

Subject to clause 4 and 9.5, [SITAERS](#) excludes all implied representations, warranties, conditions and other terms whether statutory, collateral or otherwise, relating to the subject matter of this [LicenceLicense](#) Agreement.

9.2 Indirect, special and consequential loss excluded

Subject to clause 9.5, each party excludes all liability for indirect, special and consequential loss (including without limitation for loss or corruption of data, loss of business revenue, loss of profits (whether direct or indirect), failure to realise expected profits or savings and any other economic loss of any kind) in contract, negligence or other tort, under any statute or otherwise howsoever arising from or in relation to this [LicenceLicense](#) Agreement.

9.3 Total liability

Other than for the [Licencee'sLicencee's](#) breach of the [LicenceLicense](#) in clause 2.2 of this [LicenceLicense](#) Agreement, either [party'sparty's](#) total liability to the other party for loss or damage of any kind not specified in clause 9.5, however caused (whether in contract, negligence or other tort, under any statute or otherwise howsoever) arising from or in relation to this [LicenceLicense](#) Agreement is limited in the aggregate to the amount stated as payable under clause 7 of this [LicenceLicense](#) Agreement to [SITAERS](#) by Licensee but assuming that, for these purposes only, the Software [ResidualNegotiated](#) Value is the sum of the acquisition costs of software comprising the Licensed Program in any given year amortised on a straight line basis over a three (3) year period.

9.4 Article 28 Liability

The Licensee shall indemnify and hold [SITAERS](#) harmless for any liability or claim under Article 28 of the Convention arising during the Term.

9.5 Death, personal injury or fraudulent misrepresentation

Neither party excludes or limits its liability to the other party for:

- (i) death or personal injury resulting from the negligence of that party, its employees or authorised agents; or
- (ii) fraudulent misrepresentation.

10. Notices

10.1 Notice in writing

A notice, approval, consent or other communication in connection with this [LicenceLicense](#) Agreement must be in writing, signed by the sender.

COMMERCIAL IN CONFIDENCE

10.2 Receipt of notices

They must be:

- (i) left at the address of the designated recipient at its address set out at the beginning of this Agreement;
- (ii) sent by prepaid post to such address; or
- (iii) sent by [fax](#) to the party's [fax-number](#) [email address](#) at such address.

If the intended recipient has notified a changed postal address or [fax number](#) [email address](#), then the communication must be to that address or [fax number](#) [email address](#).

11. Dispute resolution

~~11.1~~

11.1 Settle dispute expeditiously

If a dispute arises the parties undertake in good faith to use all reasonable endeavours to settle the dispute expeditiously.

12. General

12.1 Variation and waiver

A provision of this [Licence](#) [License](#) Agreement or a right created under it, may not be varied or waived except in writing, signed by the party to be bound.

12.2 Discretion in exercising rights

A party may exercise a right or remedy or give or refuse its consent in any way it considers appropriate (including by imposing conditions), unless this [Licence](#) [License](#) Agreement expressly states otherwise.

~~12.3~~ No implied waiver

The failure of a Party to exercise any right under this [Licence](#) [License](#) Agreement (which shall include the granting by a party to the other party of an extension of time in which to perform its obligations under any provision hereof) shall not be deemed to constitute a waiver of the right to exercise any such right in the future.

~~12.4~~ **12.3 Entire agreement**

This [Licence](#) [License](#) Agreement constitutes the entire agreement of the parties about its subject matter and supersedes all previous agreements, understandings and negotiations on that subject matter.

COMMERCIAL IN CONFIDENCE

12.5 12.4 Force majeure

Neither party shall be considered in default or liable for any delay or failure to perform its obligations under this LicenseeLicense Agreement if such delay or failure arises directly or indirectly out of acts of God, war, civil commotion, terrorist act, pandemic, or insurrection and which neither party is able to overcome.

12.6 12.5 Severability

If any provision of this LicenseeLicense Agreement is found by any court, tribunal or administrative body of competent jurisdiction to be wholly or partly illegal, invalid, void, voidable, unenforceable or unreasonable it shall to the extent of such illegality, invalidity, voidness, voidability, unenforceability or unreasonableness be deemed severable and the remaining provisions of this LicenseeLicense Agreement and the remainder of such provision shall continue in full force and effect.

12.7 12.6 Assignment

Licensee shall not assign, nor shall it purport to assign, this LicenseeLicense Agreement or any part thereof to any party, including any party that is a then current direct competitor of SITAERS, without the prior written consent of SITA-ERS.

13. Governing law and submission to jurisdiction

This LicenseeLicense Agreement and any dispute or claim arising out of or in connection with it or its subject matter or formation (including non-contractual disputes or claims) shall be governed by and construed in accordance with the laws of England and Wales.

The parties irrevocably agree that the courts of England and Wales shall have non-exclusive jurisdiction to settle any dispute or claim that arises out of or in connection with this LicenseeLicense Agreement or its subject matter or formation (including non-contractual disputes or claims).

The Licensee appoints General Counsel, SITA, Legal Department, 252-254 Blyth Road, Hayes, Middlesex, UB3 1HA, UK, shall, on or prior to the Effective Date, designate, by written notice delivered to ERS, a party appointed to act as its agent to receive on its behalf in England or Wales service of any proceedings pursuant to this clause 13. Such service shall be deemed completed on delivery to such agent (whether or not it is forwarded to and received by the Licensee) and shall be valid until such time as SITAERS has received prior notice from the Licensee that such agent has ceased to act as agent. If for any reason such agent ceases to act as agent or no longer has an address in England or Wales, the Licensee shall forthwith appoint a substitute and deliver to SITAERS the new agent's name, address [and fax-number email details] within England or Wales.

SITA appoints [NAME] of [ADDRESS] [FAX-NUMBER] ERS shall, on or prior to the Effective Date, designate, by written notice delivered to the Licensee, a party appointed to act as its agent to receive on its behalf in England or Wales service of any proceedings pursuant to this

COMMERCIAL IN CONFIDENCE

clause 13. Such service shall be deemed completed on delivery to such agent (whether or not it is forwarded to and received by [SITAERS](#)) and shall be valid until such time as the Licensee has received prior notice from [SITAERS](#) that such agent has ceased to act as agent. If for any reason such agent ceases to act as agent or no longer has an address in England or Wales, [SITAERS](#) shall forthwith appoint a substitute and deliver to the Licensee the new agent's name, address [and ~~fax number~~[email details](#)] within England or Wales.

14. Definitions and interpretation

14.1 Definitions

The following words have these meanings in this [LicenseeLicense](#) Agreement and the recitals:

Cape Town Instruments means the Convention and the Protocol.

Convention means the Convention on International Interests in Mobile Equipment, opened for signature in Cape Town on 16 November 2001.

Documentation -means at any time and from time to [time](#) one complete set of each of the (i) installation instructions, (ii) utilities (if any), (iii) user manual, (iv) functional and technical specifications (v) technical and ~~programmers'~~[programmers'](#) guide and similar materials as [SITAERS](#) itself uses [exclusively](#), in each case for and in relation to the International Registry.

International Registry means the international registry for railway rolling stock as established by the Cape Town Instruments.

Intellectual Property Rights means patents, trademarks, service marks, trade secrets, design rights (whether registerable or otherwise), applications for any of the foregoing, copyright, database rights, trade or business names and other similar rights and obligations whether registerable or not in any country.

[LicenseeLicensed](#) Materials means the Licensed Program and the Documentation from time to time.

Licensed Program means at any time and from time to time the most up to date version of the ~~Source Code and Object Code with~~[RegSys™ software solution conceived, created, developed or owned by ERS prior to, or independently of, the full source listings, annotations, the executable and such other materials as SITA itself uses for and in relation to development of the International Registry- or any services provided by ERS under the MSA.](#)

Luxembourg Diplomatic Conference means the diplomatic conference held in February 2007 to adopt a rail protocol to the Convention on International Interests in Mobile Equipment-

New Registrar Contract means the agreement between the Supervisory Authority and the Licensee for the operation of the International Registry.

~~**Object Code** means the machine readable format of the Licensed Program.~~

Protocol means the Luxembourg Protocol to the Convention on International Interests in Mobile Equipment on Matters Specific to Railway Rolling Stock,

COMMERCIAL IN CONFIDENCE

signed in Luxembourg on February 23, 2007.

Software Residual~~Value~~**Negotiated Value** shall be that amount being the Software Negotiated Value, if any, as certified by the Supervisory Authority pursuant to clause 38 of the Registrar Contract as the amount payable to SITAERS.

~~Source Code~~ means the human-readable format of the Licensed Program.

Supervisory Authority means the Preparatory Commission established pursuant to Resolution No. 1 of the Luxembourg Diplomatic Conference to act as provisional supervisory authority pending entry into force of the Protocol.

Term means the period from the Effective Date until the date which is the expiry or the sooner termination of the New Registrar Contract.

14.2 Reference to general terms

Unless the contrary intention appears, a reference in this Agreement to:

this "Agreement" includes any current or future amendments hereto or the annexes hereof, which form part of this LicenseLicense Agreement for all purposes;

a "party" or the "parties" is to the parties or the parties (as the case may be) to this LicenseLicense Agreement and includes any permitted assignees of a party;

the word "person" includes an individual, a firm, a corporation, an unincorporated association, government, state or agency of state, association, partnership or joint venture; and

the words "include" and "including" are not used as, nor are they to be interpreted as, words of limitation.

14.3 Headings

Headings are inserted for convenience only and do not affect the interpretation of this LicenseLicense Agreement.

14.4 Construction

No rule of construction applies to the disadvantage of a party because that party was responsible for the preparation of, or seeks to rely on, this LicenseLicense Agreement or any part of it.

14.5 Order of precedence

If there is any inconsistency between a provision in:

- (i) these terms and conditions; and
- (ii) an Annex to these terms and conditions,

then the document higher in the list above takes precedence to the extent of the inconsistency.

COMMERCIAL IN CONFIDENCE

COMMERCIAL IN CONFIDENCE

~~IN WITNESS WHEREOF~~ this Agreement is _____

SIGNED for and behalf of)
SITA)
by its duly authorised representative:)
_____ (Signature)
_____ Print name:
_____ Title:
_____ Date:

SIGNED for and behalf of)
the Licensee)
by its duly authorised representative:)
_____ (Signature)
_____ Print name:
_____ Title:
_____ Date:

COMMERCIAL IN CONFIDENCE

Annex 1

Third Party Access Agreement

THIS THIRD PARTY SYSTEM ACCESS AGREEMENT (the “**Access Agreement**”) effective as of

BETWEEN

- (1) ~~SITA Information Networking Computing (Ireland)~~Enterprise Registry Solutions Limited a company registered in Ireland with company number ~~369682358857~~ having its principal office at ~~Building Level 2, Number 4, Customs House Plaza, Harbourmaster Place, Dublin 1, Letterkenny Office Park, Windyhall, Letterkenny, Co. Donegal, Ireland~~ (“~~SITAERS~~”) and
- (2) xxxxxxxxxxxxxxx (“**Third Party**”) and
- (3) Regulis S.A. a company registered in Luxembourg with company number ~~f~~ ~~B191893~~ having its principal office at L-1330 Luxembourg, 48, boulevard Grande-Duchesse Charlotte, Grand-Duché de Luxembourg (“**Licensee**”)

WHEREAS,

- (1) ~~SITAERS~~ and Licensee have entered into a license agreement for the provision of software to facilitate the Licensee’s operation of the International Registry (as defined therein), dated [] (the “**Licence Agreement**”), pursuant to which ~~SITAERS~~ licensed to Licensee certain software products more specifically described in the Licence Agreement (hereinafter referred to as the “**Licensed Program**”);
- (2) Licensee and Third Party have entered into an software development agreement (the “**ITS Agreement**”) pursuant to which Third Party will provide services (“**Services**”) to Licensee requiring that Third Party have access to the Licensed Program; and
- (3) The parties desire that Third Party undertake appropriate contractual commitments to assure that the Licensed Program will be used only in accordance with and subject to the terms and conditions of the Licence Agreement and this Access Agreement;

NOW, THEREFORE, for good and valuable consideration, the receipt and sufficiency of which is hereby acknowledged, Licensee, ~~SITAERS~~ and Third Party hereby agree as follows:

1. ~~SITAERS~~ hereby grants Third Party the rights over the Licensed Program granted in clause 2 of the Licence Agreement for the purpose of performing its obligations pursuant to the ITS Agreement. The parties agree that Third Party’s Access of such Licensed Program shall be governed by the terms and conditions of the Licence Agreement; provided, however, Third Party may access the source code and object code forming part of the Licensed Program for the sole and exclusive purpose of providing Services to the Licensee.

COMMERCIAL IN CONFIDENCE

2. The Third Party shall keep, and shall not disclose, and shall procure that its employees and the employees of any sub-contractor shall keep, the information obtained by reason of the Access Agreement (“Confidential Information”) safe from unauthorised and accidental disclosure using the same level of care that the Third Party affords its own most confidential information, but in no event less than a reasonable level of care, except information which is in the public domain otherwise than by reason of a breach of this provision.
3. All moral rights together with any inventions, patents, copyrights, designs and any other types of intellectual property invented, devised or originated by [SITAERS](#) or any of its affiliates (or by the Third Party in breach of this Access Agreement) in relation to Confidential Information shall belong and continue to belong to [SITAERS](#) and/or the relevant one or more of its affiliates and no license is granted to the Third Party to use the same other than for the purposes specified in this Access Agreement. The Third Party agrees that, as and when requested, it will execute all necessary further documents to vest the full title to such rights, which are infringed by the Third Party in breach of this Access Agreement, in [SITAERS](#) without further payment.

COMMERCIAL IN CONFIDENCE

4. The Third Party further acknowledges and confirms to SITAERS that money damages would not be a sufficient remedy for any breach of clauses 2 and 3 by the Third Party, and that in addition to all other remedies which SITAERS may have, SITA will be entitled to specific performance and injunctive or other equitable relief as a remedy for any such breach.
5. This Access Agreement shall commence as of the date first set forth above and shall continue in effect until the earlier of (i) the termination of the ITS Agreement, (ii) SITA'sERS's receipt of written notice from Licensee that the Third Party's need to access the Licensed Program has ceased, or (iii) the termination of the Licence Agreement. Upon termination of this Access Agreement, the Third Party shall discontinue all use of the Licensed Program and; provided that the Licence Agreement has not terminated, Licensee's continued use of the Licensed Program shall be governed by the terms and conditions of the Licence Agreement. At such time, Third Party shall have no further liability or responsibility with respect to such Licensed Program.
6. At SITA'sERS's request the Third Party shall, on termination of this Access Agreement, execute a certificate of destruction in relation to any material associated with the Licensed Program to SITA'sERS's satisfaction and any such execution shall be legalized in accordance with the Third Party's jurisdiction of operation.
7. This Access Agreement and any dispute or claim arising out of or in connection with it or its subject matter or formation (including non-contractual disputes or claims) shall be governed by and construed in accordance with the laws of England and Wales. The parties irrevocably agree that the courts of England and Wales shall have non-exclusive jurisdiction to settle any dispute or claim that arises out of or in connection with this Access Agreement or its subject matter or formation (including non-contractual disputes or claims).

~~IN WITNESS WHEREOF, the parties have caused this Access Agreement to be executed as of the dates indicated.~~

Licensee _____ **THIRD PARTY**
By: _____ By: _____

Printed Name: _____ Printed Name: _____

Title: _____ Title: _____

SITA
By: _____

Printed Name: _____

Title: _____

COMMERCIAL IN CONFIDENCE

~~CONTRACT FOR THE OPERATION OF THE INTERNATIONAL REGISTRY FOR
INTERNATIONAL INTERESTS IN MOBILE EQUIPMENT
(RAILWAY ROLLING STOCK)~~

COMMERCIAL IN CONFIDENCE

ATTACHMENT VI

AMENDED AND RESTATED MASTER SERVICES AGREEMENT

[TBA]

COMMERCIAL IN CONFIDENCE

~~CONTRACT FOR THE OPERATION OF THE INTERNATIONAL REGISTRY FOR
INTERNATIONAL INTERESTS IN MOBILE EQUIPMENT
(RAILWAY ROLLING STOCK)~~

See attached Amended and Restated Master Services Agreement.

COMMERCIAL IN CONFIDENCE

ATTACHMENT VII
CHANGE CONTROL

1. Objective

The purpose of this document is to establish a framework and procedure for processing and approving changes to the International Registry ("IR") that may be required or desirable in order to:

- update the security, operation, functioning, and user-friendliness of the IR system;
- alter the Services; and
- any other changes to this Contract.

References

The following references have been used in the preparation of, and/or are referred to in, this document. Where referred to in the text, the references are abbreviated as per one of the entries in the table below.

Abbreviation	Reference
SA	Supervisory Authority
Registrar	Contractor
Convention	<i>Convention on International Interests in Mobile Equipment</i> signed at Cape Town on 16 November 2001
Protocol	<i>Protocol to the Convention on International Interests in Mobile Equipment on Matters specific to Railway Rolling Stock</i> signed in Luxembourg on 23 February 2007
Regulations	Regulations for the International Registry
Procedures	Procedures for the International Registry
Fee Schedule	Fee Schedule appended to the Procedures
Contract	Amended and Restated Contract between SA/Preparatory Commission and the Registrar for the Establishment and Operation of the International Registry between SA/Preparatory Commission and the Registrar , signed on 12th November 2014 TBD (the "Contract")
HLD	High Level Design Document, Version [—], dated [—] Appendix 1 to Attachment II of the Contract
SDIDIOR	System Design Information incorporated into the Contract, Implementation, and Operational Requirements as Attachment II of the Contract

COMMERCIAL IN CONFIDENCE

IRRCE	International Rail Registry Commission of Experts
ABIRR	Advisory Board of the International Rail Registry

Readership

The intended audience for this document consists of:

- IR staff;
- SA officials;
- Members of IRRCE; and
- Members of ABIRR.

2. Overview

2.1 The International Registry System

The IR is to be established by the Registrar under the Contract in accordance with the Convention and Protocol, and the Regulations and Procedures issued ~~there under~~ thereunder. The IR will become operational on the Go Live Date in conjunction with the entry into force of the Protocol. The IR system is to be built according to the ~~HLD and the SDI~~ DIOR.

From time to time it will be necessary to make changes to the system as a result of user feedback and/or in the interest of updating its security, efficiency and user friendliness. A procedure is required in order to process user feedback and determine, on a periodic basis, whether such changes are appropriate, the timing and frequency of the changes and the mechanism for processing the changes.

The SA is empowered to amend the Regulations and the Procedures, and changes to the IR system design can be brought about through changes ~~into~~ to the ~~HLD and the SDI~~ DIOR.

2.2 The Role of the Supervisory Authority

The SA exercises its functions pursuant to Article 17 of the Convention, Article XII of the Protocol.

The SA intends to establish IRRCE pursuant to Article XII (5) of the Protocol to assist in the discharge of its functions. IRRCE is to be consulted by the SA as needed.

The SA has the right to initiate Change Control procedures for the first and second level changes. In doing so, it shall closely coordinate with the Registrar.

2.3 User Feedback Channels

ABIRR, consisting primarily of professional users of the IR, will be established by the Registrar to provide user input on matters relating to the needs of users in connection with the operation, procedures and practices of the IR. While ABIRR is not intended to be the exclusive channel for receiving user input, it will provide a mechanism for consolidating comments and recommendations from a sector representing substantial users and user groups. ABIRR is to hold regular meetings where feedback from the membership is solicited.

In addition, the Registrar will participate in or organize, in consultation with SA, conferences, seminars and workshops, and conducts a number of demonstrations and familiarization exercises with individual users and/or groups of users in the form of online tutorials or otherwise. These, *inter alia*, are to serve the purpose of facilitating a dialogue between the

COMMERCIAL IN CONFIDENCE

Registrar and relevant user groups/representatives on the functioning of the IR, including proposed changes to the system.

The Registrar will log and classify all user feedback and ABIRR feedback regarding proposed changes to the system. The Registrar shall provide to SA, upon request, information obtained from the users, either directly, or through ABIRR. The Registrar shall maintain a Comprehensive Issues List which summarizes the items requiring system changes, and which shall be available to the SA upon request.

2.4 Change Control Process

The following classification of proposed changes and associated procedures shall apply to the changes to the IR system and shall be collectively referred to as the Change Control Process:

2.4.1 The proposed changes to the IR system shall be classified as follows:

2.4.1.1 The changes impacting the Contract, the Regulations, the Procedures and/or the Fee Schedule shall hereinafter be called "first level changes";

2.4.1.2 The facilitating changes, which are technical changes to the IR system to ensure that it continues to operate in conformity with the Convention, the Protocol, the Contract, the Regulations and the Procedures (including amendments thereto resulting from approved first level changes), or to enhance the functionality of the system for users or the ability of the Registrar to manage the IR, shall hereinafter be called "second level changes"; and

2.4.1.3 The changes to the system required to correct any malfunctions in the IR system shall hereinafter be called "third level changes".

2.4.2 For the purpose of classifying the proposed changes, the Registrar and the SA may consult informally before initiating the procedures outlined below.

2.4.3 First Level Changes

2.4.3.1 The amendment proposals for first level changes shall be transmitted by the Registrar to the SA or vice versa in accordance with paragraph 2.4.6 below, for its consideration and approval.

2.4.3.2 The SA and the Registrar shall review and consult on the proposed first level changes to the system.

2.4.3.3 The SA may instruct the Registrar to prepare such changes to the IR system as are considered necessary following the review and consultation referred to in 2.4.3.2.

2.4.3.4 The Registrar shall obtain timeframe and cost estimates for proposed changes and submit these estimates to the SA.

2.4.3.5 The SA shall approve or disapprove the proposed changes following submission to it by the Registrar of the timeframe and cost estimates referred to in 2.4.3.4. In doing so, it shall give consideration to, among other things: the perceived benefits of any change; the cost estimates of any change associated with a request for a fee increase or the addition of a new fee; the requirement for the IR to operate on a cost-recovery basis; the contribution of any change to the overall functioning of the IR; and the timeframe and the need to avoid potential disruptions to the operation of the IR.

2.4.3.6 If the Registrar proposes a change to the fees at [Table 1 of listed in](#) the Fee Schedule, the SA shall use All Reasonable Efforts to revert expeditiously with a decision as to the proposed change.

COMMERCIAL IN CONFIDENCE

2.4.4 Second Level Changes

2.4.4.1 The second level changes shall be subject only to a notification procedure as follows:

- (a) the changes shall be processed in accordance with paragraph 2.4.6 below;
- (b) each intended change shall be notified by the Registrar to the SA or vice versa no later than one (1) month prior to its intended implementation;
- (c) if the SA considers that the intended change falls under the category of first level changes, the Registrar shall be notified accordingly within that period and the change shall be treated as a first level change under paragraph 2.4.3 above; and
- (d) if, within the period of one (1) month after notification to the SA by the Registrar of an intended change, the SA notifies the Registrar that it has no objection or makes a notification pursuant to 2.4.4.1(c), the Registrar may implement the intended change.
- (e) the Registrar, upon being notified by the SA of an intended change pursuant to 2.4.4.1(b), shall implement the change unless, within the period of one (1) month after notification to the Registrar, the Registrar notifies the SA of the need for consultations regarding the intended change and, following consultations between the SA and the Registrar, the SA modifies or withdraws its notification.

2.4.5 Third Level Changes

The Registrar shall give *post facto* notification of third level changes to the SA as they occur, but no less than once a year.

2.4.6 Proposals and Notifications of Changes

The proposals of the SA referred to in paragraph 2.4.3 and 2.4.4.1 shall be recorded in writing by the SA and sent to the Registrar. The proposals and notifications referred to in paragraphs 2.4.3 and 2.4.4 above respectively shall be recorded in writing by the Registrar and sent to the SA in the following formats:

2.4.6.1 For first level changes, an International Registry Change Request Approval Form (sample at Annex I);

2.4.6.2 For second level changes, an International Registry Change Notification Form (sample at Annex II), which shall include the technical specification for that change covering, *inter alia*, hardware/software specifications, web site user ~~work~~ [flowworkflow](#) and associated texts.

2.4.6.3 For third level changes, an International Registry Change Information Form (sample at Annex III)

2.4.7 Second level changes and third level changes (where applicable) shall be bulked together and released in batches that shall occur no more than three (3) times a year at a timeframe to be agreed. This excludes any changes which SA and the Registrar

COMMERCIAL IN CONFIDENCE

may jointly agree would be beneficial to implement expeditiously and urgent second level changes.

2.4.8 The [HEDDIOR](#) is a live document and as such must reflect changes to the IR system design as they occur. To that end, the Registrar shall update the [HEDDIOR](#) upon implementation of IR system changes covered under this Change Control Process and shall concurrently record the dates of implementation in a table annexed to the [HEDDIOR](#). The Registrar shall send the updated [HEDDIOR](#) to the SA.

2.4.9 The User Manual is a document which describes the IR system from a registry user's perspective. As such, certain changes made to the [HEDDIOR](#) will need to be reflected in the User Manual, and the Registrar shall update the Manual accordingly.

2.5 Budget Cycle

Any cost required which is not addressed through the three levels described in paragraphs 2.4.3 to 2.4.5 above shall be handled through the budget cycles [in clauses 10.7 and 10.8](#).

COMMERCIAL IN CONFIDENCE

**ANNEX I
TO THE CHANGE CONTROL PROCESS**

International Rail Registry Change Request Approval Form for First Level Changes

Change Title:
Change Order number:
Change submitted to SA on:
Priority: (P1/P2)

Registrar's view of this change:

Impacts Fees _____ (Yes/No)
Impacts Regulations and/or Procedures _____ (Yes/No)
Seeking Pre Approval to begin software development _____ (Yes/No)
Seeking Final Approval to go live _____ (Yes/No)

Classification of change (select all that apply)

Improved user efficiency _____ (Yes/No)
Improved user interface _____ (Yes/No)
Enhanced functionality _____ (Yes/No)
Improve clarity _____ (Yes/No)
User request _____ (Yes/No)
Security issue _____ (Yes/No)
Compliance issue _____ (Yes/No)
Improved Registrar administration / efficiency _____ (Yes/No)
Any other: _____ (Yes/No)

Registrar's view of this change:

Impacts Fees _____ (Yes/No)
Impacts Regulations and/or Procedures _____ (Yes/No)
Seeking Pre Approval to begin software development _____ (Yes/No)
Seeking Final Approval to go live _____ (Yes/No)

Classification of change (select all that apply)

Improved user efficiency _____ (Yes/No)
Improved user interface _____ (Yes/No)
Enhanced functionality _____ (Yes/No)
Improve clarity _____ (Yes/No)
User request _____ (Yes/No)
Security issue _____ (Yes/No)
Compliance issue _____ (Yes/No)
Improved Registrar administration / efficiency _____ (Yes/No)
Any other: _____ (Yes/No)

Problem Statement:

Describe the problem:

Proposed change:

COMMERCIAL IN CONFIDENCE

Impact on Regulations and Procedures:

Benefits:

Does this change benefit all users or a subset?

Risks (if change made and if change not made):

Registrar's position:

Change description:

Software changes:

Regulations and/or Procedures change:

Timeline for implementing change:

Cost estimate:

Incremental Cost taking into account efficiencies/savings

Estimated change in fees:

Timeline for cost recovery:

Associated documents:

COMMERCIAL IN CONFIDENCE

**ANNEX II
TO THE CHANGE CONTROL PROCESS**

International Rail Registry Change Notification Form for Second Level Changes

Change Title:
Change Order number _____ :
Change submitted to SA on:
Priority (P1/P2):

Registrar's view of this change:

Impacts Fees _____ (Yes/No)
Impacts Regulations and/or Procedures _____ (Yes/No)

Classification of change (select all that apply)

Improved user efficiency _____ (Yes/No) _____
Improved user interface _____ (Yes/No) _____
Enhanced functionality _____ (Yes/No) _____
Improve clarity _____ (Yes/No) _____
User request _____ (Yes/No) _____
Security issue _____ (Yes/No) _____
Compliance issue _____ (Yes/No) _____
Improved Registrar administration / efficiency _____ (Yes/No) _____
Any other: _____ (Yes/No) _____
Change resulting from an approved first level change: _____ (Yes/No) _____
{Change resulting from a rail registry requirement: _____ (Yes/No)}

Problem Statement:

Describe the problem:

Proposed change:

Impact on Regulations and Procedures:

Benefits:

Does this change benefit all users or a subset?

COMMERCIAL IN CONFIDENCE

Risks (if change made and if change not made):

Registrar's position:

Change description:

Hardware/Software changes:

Regulations and/or Procedures change:

Timeline for implementing change:

Cost estimate:

Incremental Cost taking into account efficiencies/savings

Estimated change in fees:

Timeline for cost recovery:

Associated documents:

COMMERCIAL IN CONFIDENCE

**ANNEX III
TO THE CHANGE CONTROL PROCESS**

International Rail Registry Change Information Form for Third Level Changes

Change Title:

Change Order number _____:

Change submitted to SA on:

Date change implemented:

Registrar's view of this change:

Registrar's view of this change:

No impact on Fees _____

No impact on Regulations and/or Procedures _____

Classification of malfunction remedied (select all that apply)

User issue _____ (Yes/No) _____

Security issue _____ (Yes/No) _____

Compliance issue _____ (Yes/No) _____

Registrar administration / efficiency _____ (Yes/No)

Any other: _____ (Yes/No)

Change resulting from an approved first level change: _____ (Yes/No)

{Change resulting from a rail registry requirement: _____ (Yes/No)}

Problem Statement:

Describe the problem:

Change implemented:

Benefits:

Does this change benefit all users or a subset?

COMMERCIAL IN CONFIDENCE

Registrar's position:

Change description:

Timeline for implementing change:

Cost estimate:

Incremental Cost taking into account efficiencies/savings

Timeline for cost recovery:

Associated documents:

COMMERCIAL IN CONFIDENCE

~~CONTRACT FOR THE OPERATION OF THE INTERNATIONAL REGISTRY FOR
INTERNATIONAL INTERESTS IN MOBILE EQUIPMENT
(RAILWAY ROLLING STOCK)~~

COMMERCIAL IN CONFIDENCE

ATTACHMENT VIII

PROJECT IMPLEMENTATION PLAN

The International Registry Project Schedule is divided into two basic parts. Part One of the schedule focuses on those activities up to the point where the software development phase begins. Many of the activities take place prior to the Commencement Date however their relationship to activities following the Commencement Date are important and are therefore reflected below (Part One). Part Two of the schedule involves those activities that must be addressed as part of the software development and operational implementation of the International Registry. Both Parts of the schedule include suggested owners for the particular task.

Part One — Pre-Software Development

	Task Name	Duration	Start	Finish	Resource Names
1	Phase 1 - Finalise Negotiations and SIGN	118 days	Mon 6/2/14	Wed 11/12/14	
2	Contract Finalization	4 days	Mon 6/2/14	Thu 6/5/14	SITA, Prep Comm
3	SITA Approval Process	39 days	Fri 6/6/14	Wed 7/30/14	SITA
4	PrepComm Approval Process	81 days	Wed 7/9/14	Wed 10/29/14	Prep Comm
5	Director Rail Co Assigned	0 days	Wed 8/20/14	Wed 8/20/14	SITA
6	Contract Signatures	1 day	Wed 11/12/14	Wed 11/12/14	SITA, Prep Comm
7	Phase 2 - Drive Initial Ratifications	168 days	Thu 12/11/14	Mon 8/3/15	
8	RegCo Agree Ratification Strategy	48 days	Thu 12/11/14	Mon 2/16/15	Regulis, Prep Comm
9	RegCo Attend conferences and meetings to drive ratification	120 days	Tue 2/17/15	Mon 8/3/15	Regulis, Prep Comm
10	Viable Ratifications exist, Target Date Set & Fees Agreed	0 days	Mon 8/3/15	Mon 8/3/15	Regulis, Prep Comm
11	Project Mgr Assigned (part time initially)	0 days	Mon 8/3/15	Mon 8/3/15	SITA
12	Phase 3 - Pre Development Activities	307 days	Thu 11/13/14	Fri 1/15/16	
13	Key Contracts to Draft Stage / Regs&Proc	210.5 days	Thu 11/13/14	Thu 9/3/15	
14	Expose Draft Regulations (Attach II (App 2 - Baseline Regs) to Contract)	21 days	Thu 11/13/14	Thu 12/11/14	Regulis, Prep Comm
15	Set Up Governance Arrangements	22.5 days	Tue 8/4/15	Thu 9/3/15	Prep Comm, Regulis
16	Approve Regulations Draft 1st Edition (v1 for Development)	0 days	Mon 8/3/15	Mon 8/3/15	Prep Comm
17	Official Notification to Begin Development	0 days	Mon 8/3/15	Mon 8/3/15	Prep Comm, Regulis, SITA
18	Investment Phase	119 days	Tue 8/4/15	Fri 1/15/16	
19	Establish SITA Delivery/Development Team	20 days	Tue 8/4/15	Mon 8/31/15	SITA
20	Begin Hiring Registrar Team	45 days	Tue 8/4/15	Mon 10/5/15	Regulis
21	Formalize Key Support Contracts (Hardware, Data Center, Facilities, Certificates, Credit Card processing)	60 days	Tue 8/4/15	Mon 10/26/15	SITA, Regulis
22	Negotiate and Sign Other necessary Contracts	119 days	Tue 8/4/15	Fri 1/15/16	SITA, Regulis

COMMERCIAL IN CONFIDENCE

Part Two—Software Development and Operational Implementation

	Task Name	Duration	Start	Finish	Resource Names
23	Phase 4 - Establishment Phase	250 days?	Mon 8/3/15	Mon 7/18/16	
24	Development Kick Off Meeting	2 days	Tue 8/4/15	Wed 8/5/15	SITA,Regulis
25	Hire Operations Staff (RO)	59 days	Wed 1/6/16	Mon 3/28/16	SITA
26	Operations Staff Training (RO)	59 days	Tue 3/8/16	Fri 5/27/16	SITA
27	Software Component	150 days	Tue 8/18/15	Mon 3/14/16	
28	Requirements Specification Agreed	10 days	Tue 8/18/15	Mon 8/31/15	Regulis, SITA
29	Functionality Review Meeting 1	0 days	Mon 10/26/15	Mon 10/26/15	SITA,Regulis,Prep Comm
30	Functionality Review Meeting 2	0 days	Mon 12/7/15	Mon 12/7/15	SITA,Regulis,Prep Comm
31	Functionality Review Meeting 3	0 days	Mon 2/1/16	Mon 2/1/16	SITA,Regulis,Prep Comm
32	Functionality Review Meeting 4	0 days	Mon 3/14/16	Mon 3/14/16	SITA,Regulis,Prep Comm
33	Hardware Components	151 days?	Tue 9/1/15	Tue 3/29/16	
34	Hardware Design Confirmed	10 days	Tue 9/1/15	Mon 9/14/15	SITA,Regulis
35	Hardware Configuration and Test	20 days	Tue 2/2/16	Mon 2/29/16	SITA
36	Final As-Built System Design documentation	1 day?	Tue 3/29/16	Tue 3/29/16	SITA
37	Test and Acceptance	63.67 days	Mon 4/11/16	Fri 7/8/16	
38	PAT and Acceptance Criteria Submitted to Registrar	0 days	Mon 4/11/16	Mon 4/11/16	SITA,Regulis,Prep Comm
39	Draft User manual provided to Preparatory Commission	0 days	Mon 4/25/16	Mon 4/25/16	SITA,Regulis
40	PAT	3.33 days	Tue 5/31/16	Fri 6/3/16	SITA,Regulis,Prep Comm
41	FAT	3.33 days	Tue 7/5/16	Fri 7/8/16	SITA,Regulis,Prep Comm
42	Operations Support Model	25 days	Thu 4/21/16	Thu 5/26/16	
43	Operations Services Guide	25 days	Thu 4/21/16	Thu 5/26/16	SITA
44	Operations Support in Place	0 days	Thu 5/26/16	Thu 5/26/16	SITA,Regulis
45	Administrative Establishment	238 days	Mon 8/3/15	Thu 6/30/16	
46	Establish Office (Regulis S.A.)	0 days	Mon 8/3/15	Mon 8/3/15	Regulis
47	OTIF and Unidroit announce appointees to the Supervisory Authority per Article XII of the Luxembourg Protocol	0 days	Fri 4/22/16	Fri 4/22/16	OTIF,UNIDROIT
48	Establish Office (SITA Ops)	20 days	Wed 2/3/16	Tue 3/1/16	SITA
49	Initial Procedures Review	20 days	Mon 5/16/16	Fri 6/10/16	SITA,Regulis
50	Final Procedures Review	9 days	Mon 6/20/16	Thu 6/30/16	
51	Phase 5 - Regulations - Ready for Go Live	250 days?	Tue 8/4/15	Mon 7/18/16	
52	Draft Changes to Regulations	15 days	Mon 5/9/16	Fri 5/27/16	Supervisory Authority
53	Regulations will be published for public comment	1 day?	Tue 8/4/15	Tue 8/4/15	
54	Sign Off Regulations First Edition	36 days	Mon 5/30/16	Mon 7/18/16	Supervisory Authority
55	Phase 6 - Live Operational Phase (Go Live Date)	4 days	Fri 7/15/16	Thu 7/21/16	
56	Agree Procedures	1 day	Fri 7/15/16	Mon 7/18/16	SITA,Regulis
57	Verify Completion of System Testing (FAT)	1 day	Fri 7/15/16	Mon 7/18/16	SITA,Regulis
58	Review Pre-Operations Check List	3 days	Mon 7/18/16	Thu 7/21/16	SITA,Regulis
59	Go Live	0 days	Thu 7/21/16	Thu 7/21/16	SITA,Supervisory Authority

INDICATIVE PROJECT IMPLEMENTATION PLAN

The Project Implementation Plan will be developed in conjunction with key Preparatory Commission stakeholders utilising proven registry and project management methodologies. It will include activities related to key streams including technology, operational preparation, contract and ratification efforts, advancement of regulations and Registrar establishment.

Specific to the registry technology, it is anticipated that implementation will occur over a 9-12 month period, including design and engagement with key stakeholders, and extensive testing. The technology project plan will include three primary phases: definition, implementation and transition. The following table captures key activities anticipated in each of the phases.

Definition	Implementation	Transition
------------	----------------	------------

COMMERCIAL IN CONFIDENCE

(0-3 months)	(6-9 months)	(0-3 months)
<ul style="list-style-type: none"> • <u>Stakeholder engagement</u> • <u>User interface/user experience design and workshops</u> • <u>Workflow design and development</u> • <u>Project plan</u> • <u>Project backlog development</u> 	<ul style="list-style-type: none"> • <u>Project backlog refinement</u> • <u>Configuration and development activities</u> • <u>Implementation utilising DevOps</u> • <u>Testing (including automated testing, regression testing, nightly test runs, cyber security testing, accessibility compliance testing and performance testing)</u> 	<ul style="list-style-type: none"> • <u>User acceptance testing</u> • <u>Non-functional testing (including security and penetration testing)</u> • <u>Training and development of online tutorials</u>

The above ~~start dates and end dates~~ items are for illustrative purposes only. A completed project implementation plan, as agreed to between Contractor and the Supervisory Authority, will be provided ~~on the Notification Date~~ at a later date.

COMMERCIAL IN CONFIDENCE

~~CONTRACT FOR THE OPERATION OF THE INTERNATIONAL REGISTRY FOR
INTERNATIONAL INTERESTS IN MOBILE EQUIPMENT
(RAILWAY ROLLING STOCK)~~

COMMERCIAL IN CONFIDENCE

ATTACHMENT IX

HANDOVER PACKAGE

1. Key Contacts

A list of all staff to include the Registrar and all directors and managers with responsibility for the operation of the International Registry. This list must include the name, address, home, office and mobile telephone numbers, and a brief description of the person's role and responsibilities in the business.

2. Property

A list of all real estate owned, leased, operated or occupied by the Contractor which shall include the address, telephone number and contract telephone number of each property. Where applicable, the list will also include the name, address and telephone number of any lessor and/or the party which has granted authority to use or occupy the property, and any relevant reference numbers applicable to that lease or occupation.

3. Insurance

A list of names, addresses and telephone numbers of all insurers and any relevant broker providing insurance to the Contractor, together with the relevant policy numbers and other references and details of any outstanding claims or unresolved disputes.